



www.es-toolbox.com

Automatic  
Transmission  
cleaner and oil exchanger

# 3000 PRO

Cod. 02.022.70



Lava cambi automatici  
manuale



Manual cleaner and  
exchanger for  
automatic gearboxes



Nettoyeur manuelle  
de boîte de vitesse



Ölwechsel- und  
Reinigungsgerät  
für Automatikgetriebe,



Banco manual de limpieza y  
sustitucion del aceite de  
los cambios automaticos



Устройство очистки  
автоматических коробок  
переда, ручное управление

L'apparecchio può operare su oltre  
4000 modelli delle seguenti marche:

The machine can operate on over  
4000 models by the following brands :

L'appareil peut travailler sur plus de  
4000 modèles des marques suivantes :

Das Gerät kann mit mehr als 4000 Mod. folgender Auto-  
hersteller arbeiten:

La máquina puede utilizarse más de  
4000 modelos de las marcas siguientes:

Установка работает на более чем  
4000 моделях следующих марок:

ALFA ROMEO, AUDI, BMW,  
CHEVROLET, CHRYSLER,  
CITROËN, FIAT, FORD,  
HONDA, HYUNDAI,  
ISUZU, JAGUAR, JEEP,  
KIA, LANCIA, LAND  
ROVER, LEXUS, MAZDA,  
MERCEDES BENZ,  
MITSUBISHI, NISSAN,  
OPEL, PEUGEOT,  
RENAULT, SAAB, SEAT,  
SKODA, SUBARU, SUZUKI,  
TOYOTA, VOLKSWAGEN,  
VOLVO



NEW **PRO** Manual

# ATF3000

**I PARTICOLARI CHE FANNO LA DIFFERENZA**  
**THE DETAILS THAT MAKE THE DIFFERENCE**  
**LES CARACTÉRISTIQUES QUI FONT LA DIFFÉRENCE**  
**DIE DETAILS MACHEN DEN UNTERSCHIED AUS**  
**LOS DETALLES QUE HACEN LA DIFERENCIA**



- A. **Kit 1:** Contiene i raccordi di vetture EU e Asiatiche <2001
- B. **Kit 2:** Contiene adattatori e raccordi di vetture EU e Asiatiche dal 2002 ai piu' recenti
- C. **Dipstick:** Dispositivo per operare su cambi sigillati senza scambiatore o in caso di difficoltà di accesso ai punti di intersezione
- D. **SmartPack:** Password di accesso gratuito (per 12 mesi) alla Banca Dati con informazioni tecniche riservate (foto, ubicazione raccordi, etc) e video con dimostrazione pratica su vettura
- E. **Contalitri magnetici:** Utili per il controllo visivo dei livelli (olio usato, olio nuovo)
- F. **Versione 220V** con interruttore generale e protezione da cortocircuito e sovraccarichi
- G. **Illuminazione taniche interne:** Essenziale per il controllo visivo dei diversi tipi di oli ATF in tanica
- H. **Iniettore additivo di 500ml** con protezione contro manovre errate
- I. **Nuove ruote con maggior piano di appoggio** per agevolata movimentazione



- A. **Kit 1:** Contiene los accesorios de los coches europeos y asiáticos fechados <2001
- B. **Kit 2:** Contiene los adaptadores y accesorios para coches fechados desde 2002 hasta los más recientes
- C. **Dipstick:** Dispositivo para operar en las cajas de cambio selladas sin intercambiador de calor o en caso de dificultad de acceso a los puntos de intersección
- D. **SmartPack:** Contraseña para el acceso gratuito (por 12 meses) a la base de datos con informaciones técnicas reservadas (fotos, posiciones empalmes, etc) e video con una demostración práctica realizada en el coche
- E. **Mostrador de litros magnetico:** Útil para el control visual de los niveles (aceite usado, aceite nuevo)
- F. **Versión 220V** con interruptor de alimentación y protección contra cortocircuitos y sobrecargas
- G. **Illuminación de los tanques internos:** Esencial para el control visual de los diferentes tipos de aceites ATF en el tanque
- H. **Inyector de aditivo de 500 ml** con protección contra el mal trato
- I. **Nuevas ruedas con mayor superficie de apoyo** para movimientos más fáciles



- A. **Kit 1:** It contains the fittings of EU and Asian cars dated <2001
- B. **Kit 2:** it contains adapters and fittings for cars from 2002 to the most recent ones
- C. **Dipstick:** Device for operating on sealed gearboxes without heat exchanger or in case of difficult access to points of intersection
- D. **SmartPack:** Password for free access (for 12 months) to database with reserved technical information (pictures, fitting location, etc) and video with a practical demonstration performed on the car
- E. **Magnetic liters' counters:** Useful for visual control of the levels (used oil, new oil)
- F. **220V version** with power switch and protection against short circuits and overloads
- G. **Lighting of the internal tanks:** Essential for the visual control of the different types of ATF oils in the tank
- H. **500ml additive injector** with protection against mishandling
- I. **New wheels with larger supporting surface** for easier movements



- A. **Kit 1:** enthält Adapter für europäische und asiatische Fahrzeuge bis 2001 Baujahr
- B. **Kit 2:** enthält Adapter für Fahrzeuge von 2002 bis zu den neuesten Modellen.
- C. **Dipstick:** Dipstick-System für Ölwechsel über den Ölmesstab
- D. **SmartPack:** Passwort für den kostenlosen Zugang (12 Monate) zur Datenbank mit vorbehaltenen technischen Infos (Bilder, Fittingsstellen usw.) und Video mit dem Trainingskurs über die ATF-Verwendung
- E. **Magnetischer Literzähler:** für die visuelle Niveauekontrolle (Altöl, Frischöl)
- F. **Version 220V** mit dem Hauptschalter und Schutz gegen Kurzschluss und Überlast
- G. **Hintergrundbeleuchtung der Ölbehälter:** für die visuelle Kontrolle verschiedener Arten von ATF-Ölen im Öltank
- H. **Behälter für Zusatzmittel 500ml** mit dem Schutz gegen Fehlbedienung
- I. **Neue Räder mit einer größeren Auflagefläche** für erleichterte Handhabung



- A. **Kit 1:** Il contient les raccords des voitures européennes et asiatiques datées <2001
- B. **Kit 2:** Il contient les adaptateurs et les raccords pour les voitures dde 2002 aux plus récents
- C. **Dipstick:** Dispositif pour opérer sur les boîtes de vitesses étanches sans échangeur thermique ou en cas de difficultés d'accès aux points d'intersection
- D. **SmartPack:** Password d'accès gratuit (pour 12 mois) sur la banque de données avec informations techniques réservées (photo, position raccords, etc) et video avec une démonstration pratique effectuée sur la voiture
- E. **Compteurs de litres magnétiques:** Utile pour le contrôle visuel des niveaux (huile usée, huile nouvelle)
- F. **Versión 220V** avec interrupteur et protection contre les courts-circuits et les surcharges
- G. **Illumination des réservoirs internes:** Essentiel pour le contrôle visuel des différents types d'huiles ATF dans le réservoir
- H. **Injecteur d'additif de 500ml** avec protection contre un traitement mauvais
- I. **Nouvelles roues avec une surface d'appui plus grande** pour mouvements plus faciles



- A. **Набор 1:** содержит переходники для европейских и азиатских марок автомобилей выпуска до 2001
- B. **Набор 2:** содержит переходники для автомобилей выпуска от 2002 до новейших моделей
- C. **Dipstick:** Устройство для работы с закрытыми коробками передач
- D. **SmartPack:** Доступ к базе данных (12 мес.) и видео с обучающим курсом по использованию установки ATF
- E. **Магнитный счетчик литров:** для удобного контроля уровня масла (использованное и новое масло)
- F. **Версия 220V** с включателем и защитой от короткого замыкания и перегрузки
- G. **Освещение внутренних канистр:** необходимо для визуального контроля различных типов масла ATF в канистре
- H. **Впрыск добавочной жидкости 500ml** с защитой от ошибочных действий пользователя
- I. **Большие, широкие задние колеса** для большей устойчивости установки



# Atf 3000 PRO

EQUIPAGGIAMENTO DI SERIE CON  
EQUIPPED WITH STANDARD  
ÉQUIPÉ STANDARD DE  
STANDARD AUSGERÜSTET MIT  
EQUIPO ESTÁNDAR CON  
В СТАНДАРТНЫЙ КОМПЛЕКТ ВХОДИТ

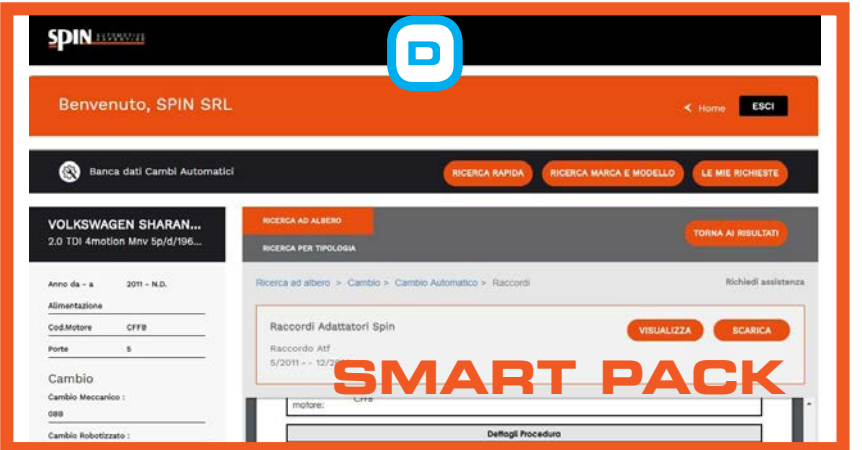
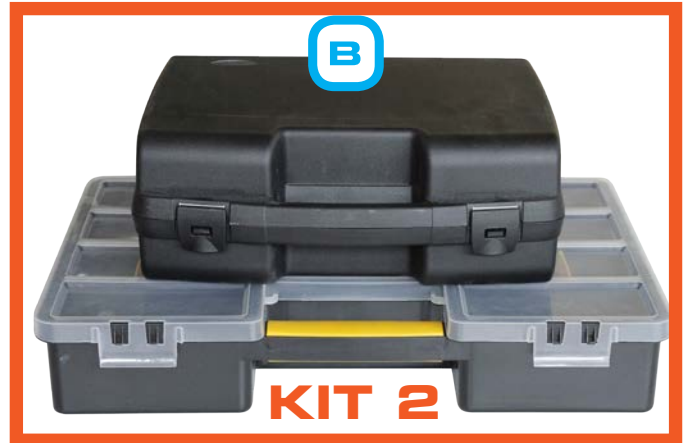
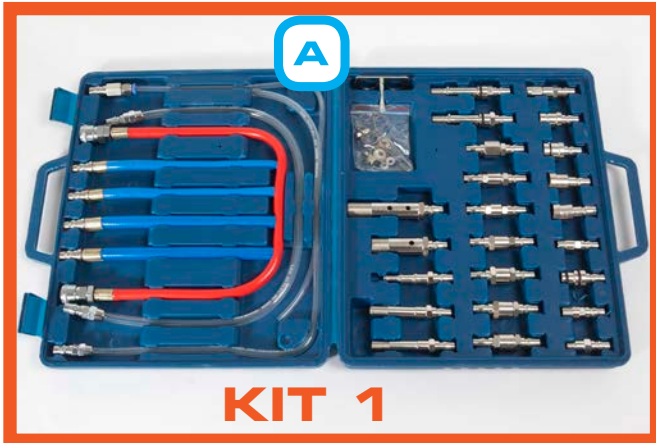

# Atf

## 3000 PRO

**RACCORDI STANDARD**  
**STANDARD FITTINGS**  
**RACCORDS STANDARD**  
**RACORES ESTÁNDAR**  
**STANDARD ADAPTERS**  
**СТАНДАРТНЫЕ ФИТИНГИ**

### KIT 1



### KIT 2



<p><b>NEW!</b> Cod. <b>02.022.11</b> AISIN (Fiat Croma, Lancia Thesis, Renault Espace, Citroen C5/C3)</p>		<p><b>NEW!</b> Cod. <b>02.022.21</b> DSG</p>		<p><b>NEW!</b> Cod. <b>02.022.52</b> VOLVO V50</p>	
<p><b>NEW!</b> cod. <b>02.022.59</b> BMW 8 MARCE/8 GEARS</p>		<p><b>NEW!</b> cod. <b>02.022.98</b> BMW 8 HP ZF</p>		<p>cod. <b>02.022.13</b> AUDI Q5/Q7</p>	
<p>cod. <b>02.022.30</b> JAP/BMW</p>	<p>cod. <b>02.022.32</b> JAP/GM</p>	<p>cod. <b>02.022.37</b> JAP/CITROEN/LANCIA</p>	<p>cod. <b>02.022.79</b> JAP/MB/HUMMER/JEEP</p>	<p>cod. <b>02.022.84</b> JAP/M14X1,5</p>	<p>cod. <b>02.022.44</b> BMW/MERCEDES 2001</p>
<p>COD. <b>02.022.07</b> BMW 2010</p>	<p>COD. <b>02.022.09</b> BMW 3 SERIES</p>	<p>Cod. <b>02.022.45</b> BMW SPECIAL</p>	<p>Cod. <b>02.022.78</b> BMW 2010</p>	<p>COD. <b>02.022.18</b> OPEL INSIGNA</p>	<p>COD. <b>02.022.63</b> VW TIGUAN/PORSCHE 911</p>
<p>Cod. <b>02.022.26</b> (ø 10) Tubo per applicazioni generali / Hose for general applications</p>		<p>Cod. <b>02.022.27</b> (ø 12) Tubo per applicazioni generali / Hose for general applications</p>		<p>cod. <b>02.022.99</b> FIAT 500 X ZF</p>	

02.022.74		> Staffa speciale per <b>Audi A8</b> > <i>Special adapter for Audi A8</i>		02.022.107		> Kit raccordi per <b>Maserati</b> > <i>Adapter kit for Maserati</i>	
02.022.62		> Blocchetto per <b>Mercedes CLK</b> > <i>Block for Mercedes Benz CLK</i>		02.022.100		> Raccordo scambiatore olio/ acqua cambio <b>Toyota Avensis K311</b> da usare con tubi gomma Ø8 cassetta standard > <i>Coupling for oil/water exchanger Toyota Avensis K311 gearbox to be used with rubber hoses Ø8 from standard case</i>	
02.022.73		> Kit per <b>Renault-Nissan</b> <2003, cambi DPO > <i>Kit for Renault - Nissan &lt;2003, transmissions DPO</i>		02.022.101		> Raccordo scambiatore aria/ olio cambio <b>Toyota Corolla</b> da usare con tubi gomma Ø8 cassetta standard > <i>Coupling for oil/water exchanger Toyota Corolla gearbox to be used with rubber hoses Ø8 from standard case</i>	
02.022.65		> Kit raccordi <b>BMW 330D</b> 180Hp > <i>Adapter kit for BMW 330D 180Hp</i>		02.022.102		> Raccordo scambiatore aria/ olio cambio <b>Mazda CX-5 (6 AT)</b> da usare con tubi gomma Ø8 cassetta standard > <i>Coupling for oil/water exchanger Mazda CX-5 (6 AT) gearbox to be used with rubber hoses Ø8 from standard case</i>	
02.022.88		> Kit per <b>Porsche Cayenne / VW Touareg / Audi Q8</b> > <i>Kit for Porsche Cayenne / VW Touareg / Audi Q8</i>		02.022.104		> Raccordo scambiatore olio/ acqua cambio <b>Nissan CVT (JF011E/REOF10A)</b> > <i>Coupling for oil/water exchanger Nissan CVT (JF011E/REOF10A)</i>	
02.022.86		> Kit raccordi <b>Volvo XC90</b> > <i>Adapter kit for Volvo XC90</i>		02.022.105		> Raccordo scambiatore olio/ acqua cambio <b>Nissan 6CVT</b> > <i>Coupling for oil/water exchanger Nissan 6CVT</i>	
02.022.61		> Kit adattatori per cambi <b>Powershift (Volvo - Ford Focus)</b> > <i>Adapter kit for Powershift gearbox (Volvo - Ford Focus)</i>		02.022.108		> Kit piastra per <b>Citroen C4/C5 PICASSO</b> > <i>Adapter kit for Citroen C4/C5 PICASSO</i>	
02.022.93		> Kit raccordi per <b>Audi 4/6 Avant</b> >2012, cambio 4G5 su scambiatore > <i>Adapter kit for Audi 4/6 Avant &gt;2012 (4G5) on oil exchanger</i>		02.022.109		> Kit piastra <b>Renault Espace</b> per <b>Nissan/Renault/Jeep/Mitsubishi</b> > <i>Adapter kit for Renault/Jatco for Nissan/ Renault/Jeep/Mitsubishi</i>	
02.022.94		> Kit adattatori per <b>Mercedes Benz</b> , cambio 722.9 > <i>Adapter kit for Mercedes Benz, 722.9 gearbox</i>		02.022.04		> Kit 2 aste livello olio Mercedes Classe A e C > <i>Kit 2 oil level dipstick Mercedes A-Class &amp; C-Class</i>	
02.022.95		> Kit adattatori per <b>TF80 MULTI</b> > <i>Adapter kit for TF80 MULTI gearboxes (Volvo, Alfa Romeo, Cadillac, Ford, Land Rover)</i>		02.000.62		> Kit per vetture USA/Giappone > <i>Kit for USA/Japan vehicles (Ford, Cadillac, Toyota, Nissan, Chrysler Jeep, GM, Dodge, Honda, Chevrolet, Chevy Duramax)</i>	
02.022.72		> Kit adattatore <b>Jatco</b> per <b>Nissan/Renault/Jeep/Mitsubishi</b> > <i>Adapter kit Jatco for Nissan/ Renault/Jeep/Mitsubishi</i>					
02.022.97		> Kit adattatore <b>Mercedes Classe A/B</b> , cambio DCT > <i>Adapter kit for Mercedes-Benz A-Class &amp; B-Class, DCT gearbox</i>					
02.022.66		> Rabboccatore livello olio > <i>Oil level refiller</i>					

# SMART PACK ATF

## ATF DATABASE ONLINE

**INCLUSO  
CON L'ACQUISTO  
DI OGNI MODELLO ATF**  
valido 12 mesi dall'attivazione

**INCLUDED  
WITH THE PURCHASE  
OF ANY ATF MODEL**  
12 months subscription



**SPIN** AUTOMOTIVE EXPERTISE

CAMBIO -> CAMBIO AUTOMATICO -> CIRCUITO IDRAGICO DI RAFFREDDAMENTO/RACCORDI

Dati Procedura	
Descrizione:	CAMBIO GA6HP192
Modello/Anno:	dal 9/2004 al 3/2007

Dati Veicolo	
Veicolo:	BMW - Serie 1 (E81-E87) - 118d Ber. 5p/d/1995cc
Modello/Anno:	dal 09/2004 al 03/2007
Codice motore:	N47D20C

Dettagli Procedura

1) Tubazione di mandata dal cambio al radiatore.      2) Tubazione di ritorno dal radiatore al cambio.

Figura 1      Figura 2

**SMART PACK ATF è un servizio di consultazione della banca dati che raccoglie informazioni tecniche riservate sui cambi automatici:**

- Identificazione rapida del veicolo:
  - ricerca per marca, modello o codice motore
  - ricerca per marca veicolo o codice del cambio
  - ricerche tramite targa veicolo (5 ricerche incluse)\*
- Ubicazione targhetta identificativa (A)
- Ubicazione componenti, procedure e adattamenti (B)
- Informazioni sull'adattatore da utilizzare per collegare il lavacambi ATF al cambio automatico (C)
- Circuito idraulico di raffreddamento
- Controllo livello olio
- Richiesta via mail di informazioni tecniche aggiuntive (10 interrogazioni incluse)\*

*\*Servizio riservato solo per l'Italia*

**SMART PACK ATF is a database consultation service that gathers confidential technical information on automatic transmissions:**

- Quick vehicle identification:
  - search by brand, model or engine code
  - search by vehicle brand or gearbox code
- Location of identification plate (A)
- Location of components (B)
- Information on the adapter to be used to connect the ATF unit to the automatic transmission (C)
- Procedures and adaptations
- Cooling hydraulic circuit
- Oil level check

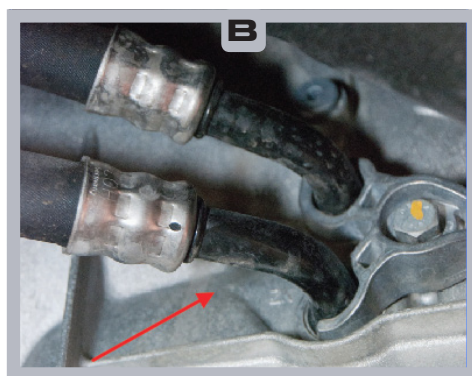
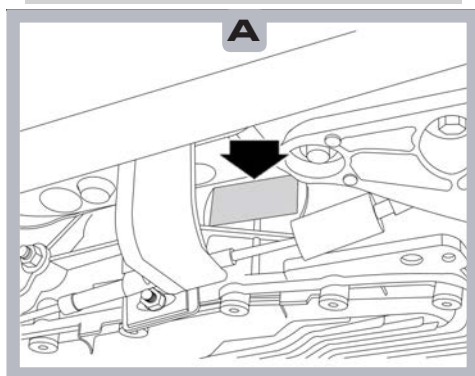

**RINNOVO ANNUALE / ANNUAL RENEWAL**

**Cod. 02.022.110**

**SMART PACK ATF**  
ATF DATABASE ONLINE