

SMART PACK ATF

ATF DATABASE ONLINE

**INCLUSO
CON L'ACQUISTO
DI OGNI MODELLO ATF**
valido 12 mesi dall'attivazione

**INCLUDED
WITH THE PURCHASE
OF ANY ATF MODEL**
12 months subscription



SPIN AUTOMOTIVE EXPERTISE

CAMBIO -> CAMBIO AUTOMATICO -> CIRCUITO IDRAGICO DI RAFFREDDAMENTO/RACCORDI

Dati Procedura	
Descrizione:	CAMBIO GA6HP192
Modello/Anno:	dal 9/2004 al 3/2007

Dati Veicolo	
Veicolo:	BMW - Serie 1 (E81-E87) - 118d Ber. 5p/d/1995cc
Modello/Anno:	dal 09/2004 al 03/2007
Codice motore:	N47D20C

Dettagli Procedura

1) Tubazione di mandata dal cambio al radiatore. 2) Tubazione di ritorno dal radiatore al cambio.

Figura 1 Figura 2

SMART PACK ATF è un servizio di consultazione della banca dati che raccoglie informazioni tecniche riservate sui cambi automatici:

- Identificazione rapida del veicolo:
 - ricerca per marca, modello o codice motore
 - ricerca per marca veicolo o codice del cambio
 - ricerche tramite targa veicolo (5 ricerche incluse)*
- Ubicazione targhetta identificativa (A)
- Ubicazione componenti, procedure e adattamenti (B)
- Informazioni sull'adattatore da utilizzare per collegare il lavacambi ATF al cambio automatico (C)
- Circuito idraulico di raffreddamento
- Controllo livello olio
- Richiesta via mail di informazioni tecniche aggiuntive (10 interrogazioni incluse)*

**Servizio riservato solo per l'Italia*

SMART PACK ATF is a database consultation service that gathers confidential technical information on automatic transmissions:

- Quick vehicle identification:
 - search by brand, model or engine code
 - search by vehicle brand or gearbox code
- Location of identification plate (A)
- Location of components (B)
- Information on the adapter to be used to connect the ATF unit to the automatic transmission (C)
- Procedures and adaptations
- Cooling hydraulic circuit
- Oil level check

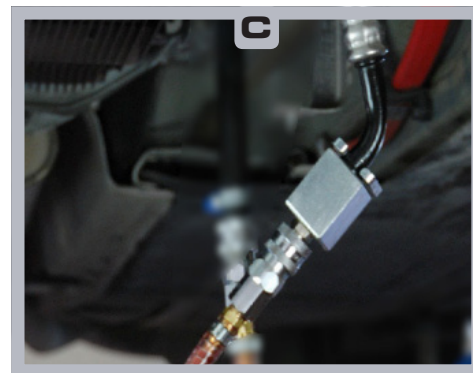
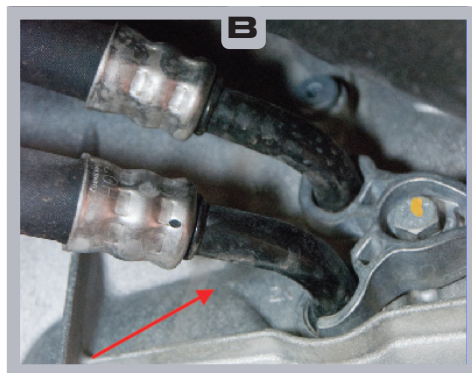
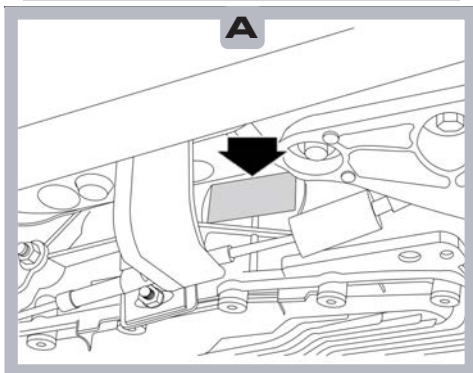

RINNOVO ANNUALE / ANNUAL RENEWAL

Cod. 02.022.110

SMART PACK ATF
ATF DATABASE ONLINE