

# VEHICLE LIFT



**GALTA**

Ed. 02-2019







# GALTA



Member of CISQ Federation



CERTIFIED MANAGEMENT SYSTEM  
ISO 9001

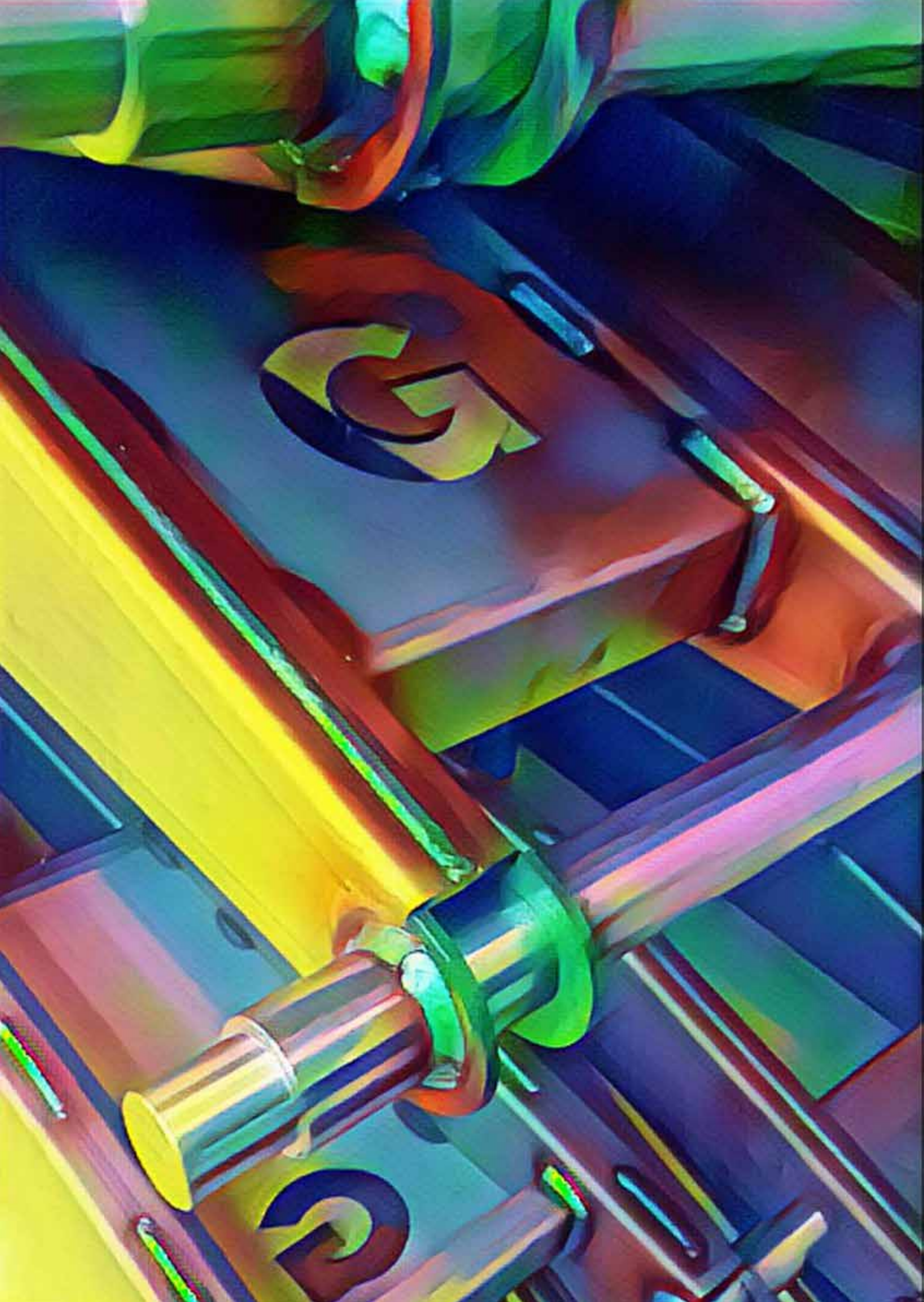





**Galta** è una realtà dinamica con una storia semplice ed esemplare: la passione di grandi professionisti per il settore automotive unita all'esperienza trentennale dello staff, ha sviluppato una imprenditoria all'avanguardia che ha lo scopo di fornire un prodotto mirato a soddisfare le esigenze dei suoi clienti a livello mondiale.

La scelta di offrire 2 linee di prodotto consente a Galta di soddisfare le esigenze dei diversi mercati sia dal punto di vista qualitativo che economico, garantendo al prodotto finito l'ineguagliabile caratteristica della **qualità made in Italy**.

Galta è specializzata nel realizzare, partendo dalla progettazione fino al prodotto finito, una completa gamma di sollevatori ad elevatissimo standard:

Grandi Forbici da allineamento da 4T a 6T	Ponti a 4 colonne piani e da assetto da 3.5T a 5.5T
Doppie Forbici con sgancio sicure meccanico/idraulico da 3T a 4T	Ponti fissi e mobili per cambio gomme
Ponti a 2 colonne elettromeccanici/elettroidraulici da 4T a 7T	Ponti da moto
Ponti da carrozzeria e cabine di verniciatura	Traverse di sollevamento ausiliarie da 2T a 3T

La qualità dei nostri prodotti è garantita da:

- forti investimenti in tecnologia che hanno lo scopo di innovare e mantenere all'avanguardia tutte le linee di prodotti.
- un selezionato e affidabile parco fornitori localizzato nel raggio di pochi chilometri dal nostro stabilimento.
- uno staff produttivo con decenni di esperienza formato da ingegneri, disegnatori tecnici e operai specializzati.
- un rigoroso controllo qualità ed un customer service veloce e sempre reperibile.

Galta si avvale di più di **14.000Mq di stabilimenti**: 4000mq in Italia, a Montecchio Maggiore (VI), che ospitano il reparto produttivo, lo showroom, gli uffici amministrativi/commerciali e la direzione; a supporto della realizzazione di componenti di carpenteria un secondo stabilimento estero di oltre 10.000mq.

Il team commerciale di Galta è strutturato e organizzato in modo da interpretare al meglio le esigenze del mercato e dei suoi partner commerciali: attraverso una selezionata rete di distributori e rivenditori fidelizzati, dislocati in più di 45 paesi del mondo, Galta commercializza i propri prodotti sviluppando per il 75 % il proprio volume d'affari sul mercato estero, di cui il 40% in Europa.

Grazie ad una esperta e virtuosa filiera professionale, formata da oltre 28 distributori e più di 40 installatori certificati, il brand Galta è capillarmente presente sul suolo nazionale.

Il nostro motto è **"BORN TO LIFT"**: le nostre attrezzature sono "nate per sollevare" e così anche lo staff Galta punta ad innalzare costantemente il livello di qualità dei propri prodotti e servizi garantendo soluzioni tecnologiche affidabili e durature nel tempo.

---

**Galta** is a dynamic company with a simple and remarkable history: the passion of great industry professionals in the automotive sector, combined with the thirty-year experience of the staff, has developed a leading-edge business that aims to provide a product targeted to meet the needs of its global customers.

The choice of supplying the market with 2 product lines allows Galta to satisfy the market in quality and economic terms, ensuring to the finished product the incomparable feature of the **Made in Italy**.

Starting from the design to the finished product Galta specializes in the manufacturing of a wide range of high-quality lifts:

Big Scissor Lifts for alignment - 4T to 6T capacity	4 Post Lifts alignment and flat version - 3.5T to 5.5T capacity
Double Scissor Lifts with mechanical/hydraulic safety release - 3T to 4T	Fixed and Mobile lifts for Tire Shop
Electromechanic/electro-hydraulic 2 post lifts - 4T to 7T capacity	Motorcycle lifts
Lifts for garage and spray booths	Rolling Jack: manual and pneumo-hydraulic - 2T/3T

The quality of our products is guaranteed thanks to:

- high investments in technology aimed at innovating and keeping all product lines at the forefront.
- a selected list of approved and reliable suppliers located within a few miles from our plant.
- a production crew, with decades of experience, made up of engineers, technical draftsman and skilled workers.
- strict quality controls and a fast and readily customer service.

Galta makes use of more than **14,000 square meters of plants**: a 4000 square meters property is located in Italy, Montecchio Maggiore (VI) and it houses the production department, the showroom, the administrative / commercial offices and the management; a second overseas plant of over 10,000 square meters is used for the construction of carpentry components.

Galta's sales team is structured and organized to interpret efficiently the needs of the market and of its trading partners requests. GALTA markets its products through a selected network of loyal distributors and resellers, located in more than 45 countries around the world, and it has developed 75% of its turnover on the foreign market, 40% of which in Europe.

Thanks to an expert and virtuous professional chain of over 28 distributors and more than 40 certified installers, the Galta brand is widely present within the Italian territory.

Just as our products are **"BORN TO LIFT"** the Galta staff also strive to constantly raise the level of quality of its products and services, guaranteeing reliable and long-lasting technological solutions.

***LIFT IT TO BELIEVE IT !!!***



***GALTA is a PERMANENT EXHIBITOR in:  
Automechanika FRANKFURT  
Autopromotec BOLOGNA***





ATTENZIONE  
RISCHIO DI  
CACCIA

VIETATO  
CLIMBARE

AVVERTENZE  
PER IL  
MANTENIMENTO  
E L'USO  
CORRETTO



A  
I  
T

# 01 LIFTS BLUE LINE

## SCISSOR LIFTS FOR ALIGNMENT | PONTI A FORBICE DA ASSETTO

GT - S400	14
GT - S600	24
GT - S500	32

## 2 POST LIFTS | PONTI A 2 COLONNE

GT - V 40	38
GT - V 40M	40
GT - V 50	46
GT - EM 2.8	52
GT - EM 3.2	54
GT - EL 40	56
GT - V80	60

# 02 LIFTS GREY LINE

## SCISSOR LIFTS FOR ALIGNMENT | PONTI A FORBICE DA ASSETTO

GT - BS	66
GT - BSL	70
GT - BSLP	72
GT - BSULP	76

## SCISSOR LIFTS AND DOUBLE SCISSOR LIFTS | PONTI A FORBICE E DOPPIA FORBICE

GT - DS MASTER	80
GT - DS	84
GT - MR 3.0	86
GT - MR 3.0 Mobile	88

## 4 POST LIFTS | PONTI A 4 COLONNE

GT - FPA - FPF	90
GT - FPA - LT	94

## 2 POST LIFTS | PONTI A 2 COLONNE

GT - TPB 4.0 BASEMENT	96
GT - TPF 4.0 AIR	98
GT - TP 4.0 TOP	100

## TWO POST LIFT WITH MANUAL RELEASE | PONTE 2 COLONNE CON SGANCIO MANUALE

GT - TP 4.0 TOP M	102
GT - TPF AIR M	104

## ONE POST LIFT | PONTE MONOCOLONNA - 2 POST PARKING LIFT | PONTE PARCHEGGIO

GT - SC 3.0	106
GT - TP 2.8 / TP 2.8 B	108

## ROLLING JACK - MOTOR JACK | TRAVERSA DI SOLLEVAMENTO

GT - RJ	110
GT - MJ	111

## BATTERY LIFT - MOTORBIKE LIFT | SOLLEVATORE BATTERIE PONTE DA MOTO

GT - BATTERY LIFT	112
GT - MC 600	113

## SINGLE PLATFORM SCISSOR LIFT | PONTEA FORBICE PEDANA SINGOLA

GT-3.0 SB - GT-3.0 SBS	114
------------------------	-----





**GALTA**



**Born to lift**







***blue line***





# STANDARD ELECTRIC PLUG CONNECTION

**BLUE LINE** = 3P+T quadripolar

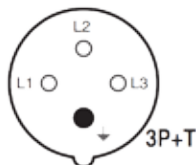

**GREY LINE** = 3P+N+T pentapolar



**ON REQUEST**  
SU RICHIESTA

## ANTI CORROSION TREATMENTS

### TRATTAMENTI ANTI CORROSIONE

On request and with extra charge all models of **BLUE LINE** can be supplied with the following anti-corrosion special treatments:

A richiesta e con sovrapprezzo sono disponibili i seguenti trattamenti speciali anti corrosione per tutti i modelli della **BLUE LINE**:

- Sandblasting / Sabbiatura
- Cataphoresis / Cataforesi

All models of **GREY LINE** have the standard sandblasting treatment.

Tutti i modelli della **GREY LINE** ricevono il trattamento di sabbiatura standard.

## RAL AVAILABLE

### RAL DISPONIBILI

#### **BLUE LINE:**

The standard color is RAL 5002 (Blue) / Colore standard RAL 5002 (Blue).

On request RAL 7016 (Grey) and RAL 3002 (Red) are available without price surcharge.

A richiesta sono disponibili in RAL 7016 (Grigio) e RAL 3002 (Rosso) senza sovrapprezzo.

All RAL are available on request with a price surcharge / Tutti i RAL disponibili con sovrapprezzo.

#### **GREY LINE:**

The standard color is RAL 7016 (Dark grey), RAL 7040 (Light grey) and Ral 3002 (Red).

Colore standard RAL 7016 (Grigio scuro), RAL 7040 (Grigio chiaro) e RAL 3002 (Rosso).



## GT - S 400



Electro-hydraulic scissor lift with automatic alignment - antiknock valves - main lift max lifting height 320 -2170 mm - LT max lifting height 500 mm - mechanical safety locks with pneumatic release (6/8 bar required) /engine power 2.6 KW - 400V/3PH/50Hz - INGROUND VERSION (floor version on request with addition of up and down ramps cod.kit: A-93014)

Sollevatore a forbice elettroidraulico con allineamento automatico - valvole paracadute - Altezza di sollevamento 320 - 2170 mm - altezza sollevamento LT 500 mm - sicure a sgancio pneumatico - potenza motore 2.6 KW - 400V/3PH/50Hz.

Richiesta connessione pneumatica per lo sgancio delle sicure 6/8 bar - VERSIONE A INCASSO (versione a pavimento a richiesta con aggiunta di rampe salita e fermo ruota cod.kit: A-93014)



**4.000 Kg**

All models with lift table are equipped with 4 rubber pads. All models can host sliding plates, turning tables, rolling jacks.

STANDARD PAINTING: BLU RAL 5002 - GREY RAL 7016

Tutti i modelli con torretta vengono forniti con 4 tamponi in gomma. Tutte le pedane possono ospitare piani oscillanti, piatti rotanti e rolling jack.

COLORI STANDARD: BLU RAL 5002 - GRIGIO RAL 7016



MODEL	PLATFORM (mm)	LIFT CAPACITY	LT CAPACITY	DESCRIPTION
<b>GT-S 400 A</b>	4960 x 660	4.0 T	-	Sliding plates - front recess length 1080 mm - central compartment with fixed cover - engine power 2.6 Kw - 400v /3ph/50Hz - Piano oscillante - incavo anteriore lunghezza 1080 mm - copertura fissa vano centrale - potenza motore 2.6 Kw - 400v /3ph/50Hz
<b>GT-S 400 ALT</b>	4960 x 660	4.0 T	3.5 T	Sliding plates - front recess length 1080 mm - LT max lifting height 500 mm - engine power 2.6 Kw - 400v /3ph/50Hz Piano oscillante - incavo anteriore 1080 mm - Lift Table altezza di sollevamento 500 mm - potenza motore 2.6 Kw - 400v /3ph/50Hz
<b>GT-S 400 F</b>	4960 x 660	4.0 T	-	Flat platforms - front recess length 1080 mm with fixed cover - central and rear recess with fixed covers - engine power 2.6 Kw - 400v /3ph/50Hz Pedana piana - incavo anteriore lunghezza 1080 mm con copertura fissa - copertura fissa vano centrale e copertura fissa vano piani oscillanti - potenza motore 2.6 Kw - 400v /3ph/50Hz
<b>GT-S 400 FLT</b>	4960 x 660	4.0 T	3.5 T	Flat platforms - front recess length 1080 mm - with fixed covers - LT max lifting height lift 500 mm - rear compartment with fixed cover - engine power 2.6 Kw - 400v /3ph/50Hz Pedana piana - incavo anteriore lunghezza 1080 mm con copertura fissa - Lift Table altezza di sollevamento 500 mm - copertura fissa vano piani oscillanti - potenza motore 2.6 Kw - 400v /3ph/50Hz
<b>GT-S 400 SA</b>	4600 x 660	4.0 T	-	Sliding plates - front recess length 1080 mm - platform length 4600 mm - central fixed full cover - engine power 2.6 Kw - 400v /3ph/50Hz Piano oscillante - incavo anteriore lunghezza 1080 mm - copertura fissa vano centrale - lunghezza pedana 4600 mm - potenza motore 2.6 Kw - 400v /3ph/50Hz
<b>GT-S 400 SALT</b>	4600 x 660	4.0 T	3.5 T	Sliding plates - front recess length 1080 mm - LT max lifting height 500 mm - platform length 4600 mm - engine power 2.6 Kw - 400v /3ph/50Hz Piano oscillante - incavo anteriore 1080 mm - Lift Table altezza di sollevamento 500 mm - lunghezza pedana 4600 mm - potenza motore 2.6 Kw - 400v /3ph/50Hz
<b>GT-S 400 SF</b>	4600 x 660	4.0 T	-	Flat platforms - front recess length 1080 mm with fixed cover - central and rear compartment with fixed covers - platform length 4600 mm - engine power 2.6 Kw/400v /3ph/50Hz Pedana piana - incavo anteriore lunghezza 1080 mm con copertura fissa - copertura fissa vano centrale e copertura vano piani oscillanti - lunghezza pedana 4600 mm - potenza motore 2.6 Kw - 400v /3ph/50Hz
<b>GT-S 400 SFLT</b>	4600 x 660	4.0 T	3.5 T	Flat platforms - front recess length 1080 mm with fixed covers - LT max lifting height 500 mm - rear fixed cover - platform length 4600 mm - engine power 2.6 Kw/400v /3ph/50Hz Pedana piana - incavo anteriore lunghezza 1080 mm con copertura fissa - Lift Table altezza di sollevamento 500 mm - copertura fissa vano piani oscillanti - lunghezza pedana 4600 mm - potenza motore 2.6 Kw - 400v /3ph/50Hz

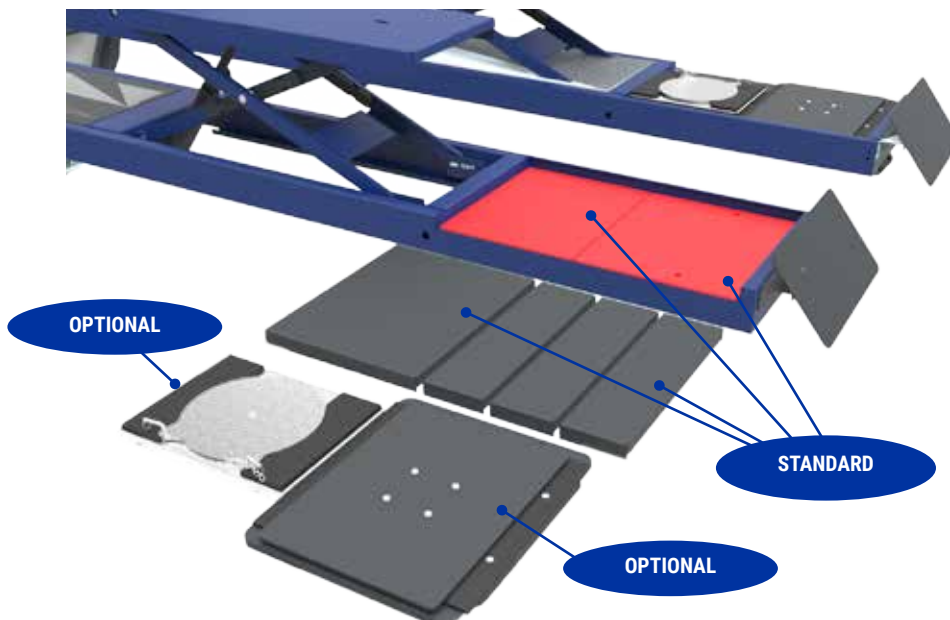

## TURNING PLATES

### Piatti rotanti

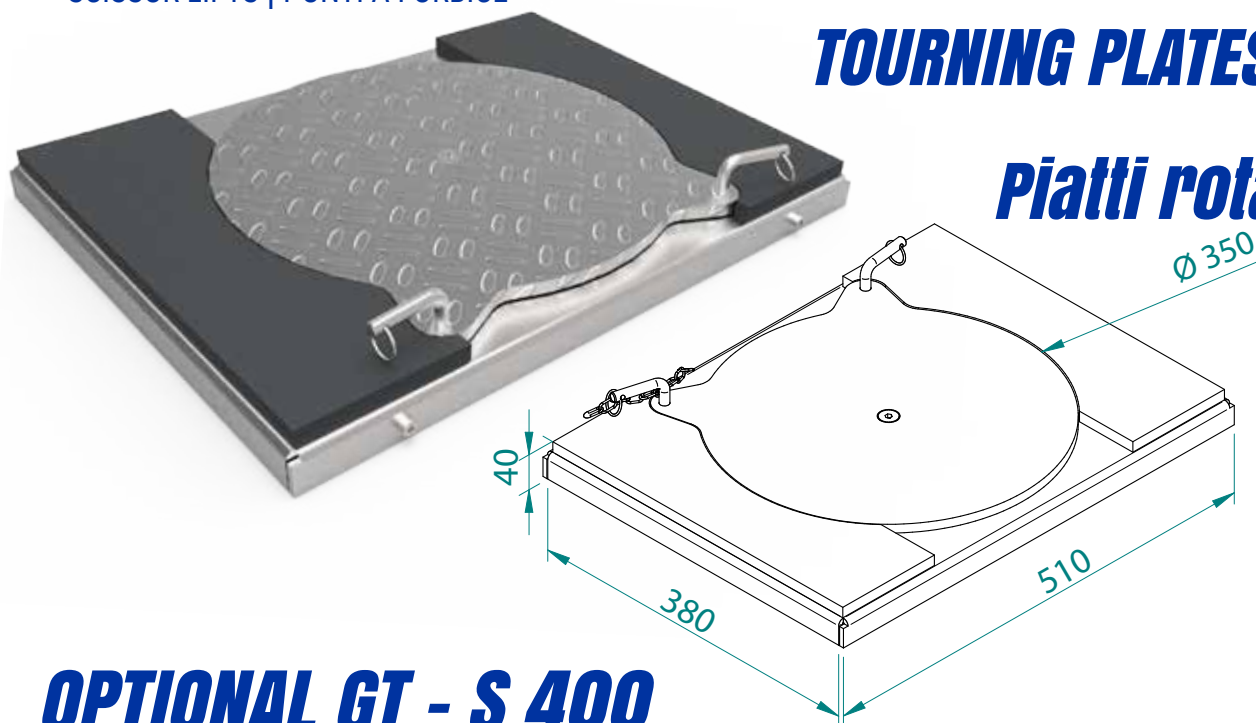

## OPTIONAL GT - S 400

CODE	DESCRIPTION	
<b>A-93013</b>	LED lamps 24 Volt - Set 4 lampade 24 Volt LED	
<b>A-93014</b>	Expansion bolts set (12 pz) - Set tasselli di fissaggio (12pz)	
<b>A-93014</b>	Approaching ramps for on ground installation - Set rampe salita per versione a pavimento	
<b>A-93016</b>	Mobile Cover for HPD - Coperture MOBILE vano HPD	
<b>A-93017</b>	Mobile Cover for TURNING PLATES - Coperture MOBILE vano PIATTI ROTANTI	
<b>A-93018</b>	Extension set for lift table (2 rubber pad included) - Set prolunghe per lift table (2 tamponi inclusi)	
<b>A-93019</b>	Set rubber pad H=60 mm (4 pz) - Set tamponi H=60 mm (4 pz)	
<b>A-93020</b>	Set rubber pad H=120 mm (4 pz) - Set tamponi H=120 mm (4 pz)	
<b>A-93024</b>	HPD 6 movements + spot light - HPD 6 movimenti + torcia	
<b>A-93025</b>	Turning plates set with covers - Set piatti rotanti con copertura	
<b>A-93021</b>	Wires-pipes extension set L= +1 m - Set estensioni tubi-cavi L= +1 m	
<b>A-93022</b>	Wires-pipes extension set L= +2 m - Set estensioni tubi-cavi L= +2 m	
<b>A-93023</b>	Wires-pipes extension set L= +3 m - Set estensioni tubi-cavi L= +3 m	
<b>A-93026</b>	Wires-pipes extension set L=+1 m - Set estensioni tubi-cavi L= +1 m	
<b>A-93027</b>	Wires-pipes extension set L=+2 m - Set estensioni tubi-cavi L+2 m	
<b>A-93028</b>	Wires-pipes extension set L=+3 m - Set estensioni tubi-cavi L+3 m	
<b>A-93039</b>	Rubber ramps H=30mm - Rampe in gomma H=30mm	ONLY FOR FLOOR VERSION / SOLO PER VERSIONE A PAVIMENTO
<b>A-93040</b>	Rubber ramps H=50mm - Rampe in gomma H=50mm	ONLY FOR FLOOR VERSION / SOLO PER VERSIONE A PAVIMENTO





**SINGLE EXTENSION 3.5T**  
ESTENSIONI TORRETTA SINGOLA 3.5T

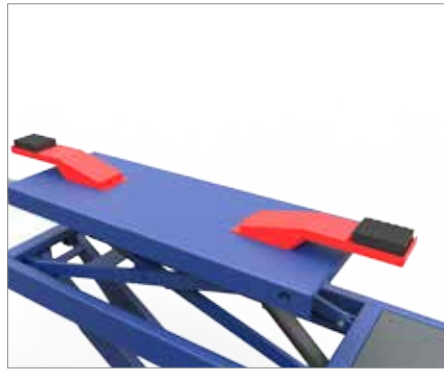

**DOUBLE EXTENSION 3T**  
ESTENSIONI TORRETTA DOPPIA 3T



**RUBBER RAMPS H=30mm**  
RAMPA IN GOMMA H=30mm



**CONTROL UNIT**  
CONTROL UNIT



**4 LED LIGHTS**  
4 LUCI A LED



**RUBBER RAMPS H=50mm**  
RAMPA IN GOMMA H=50mm



**ROLLING JACK 2T / 3T**  
ROLLING JACK 2T / 3T



**APPROACHING RAMPS**  
RAMPE SALITA

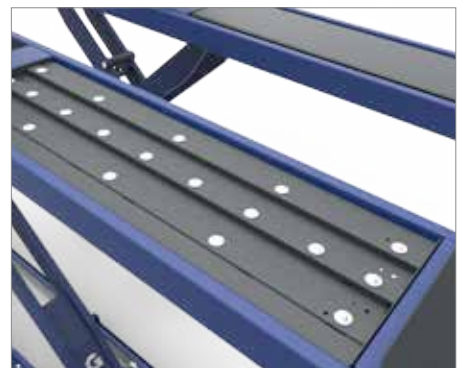

**SLIDING PLATES**  
PIANI OSCILLANTI



**SPOT LIGHT HPD**  
LAMPADA SPOT HPD



**HPD 6 MOVEMENTS**  
PROVA GIOCHI 6 MOVIMENTI

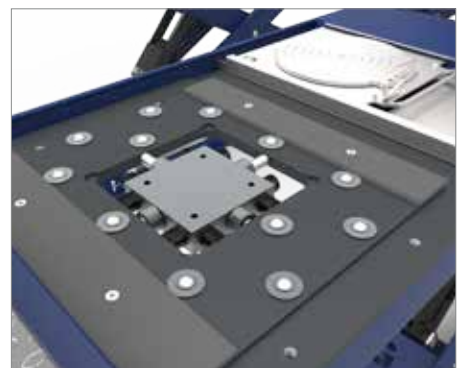







# GT - S 400



MECHANICAL SAFETY LOCK  
SICURA MECCANICA SULLE BASI



STANDARD LIFT TABLE  
STANDARD LIFT TABLE



# GT - S 400 ALT 4960mm

LT VERSION - VERSIONE CON TORRETTA

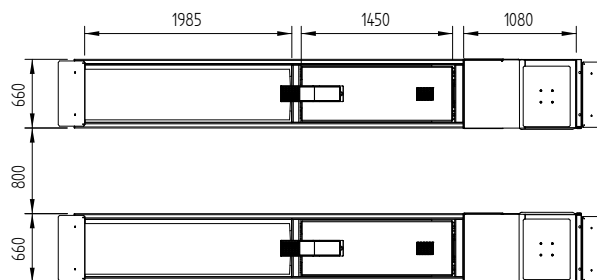
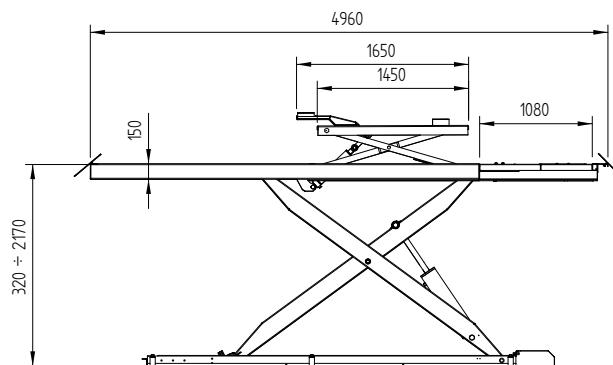
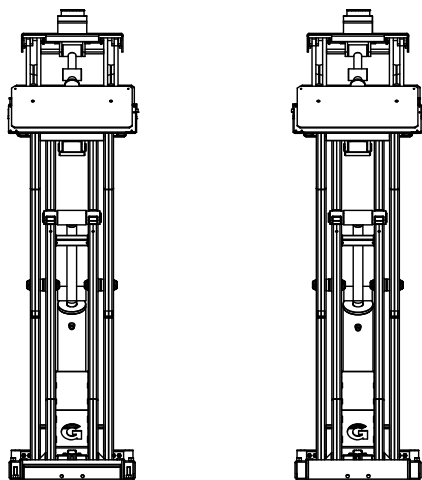

# GT - S 400 SALT 4600mm

LT VERSION - VERSIONE CON TORRETTA

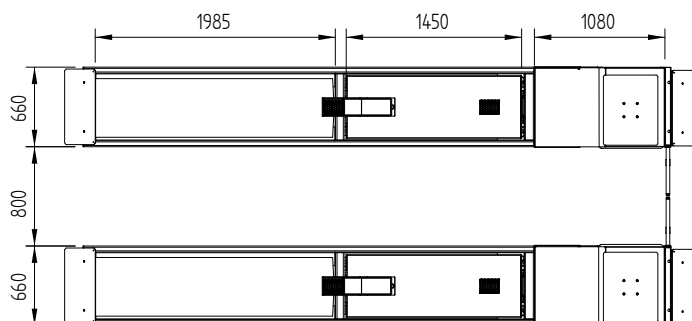
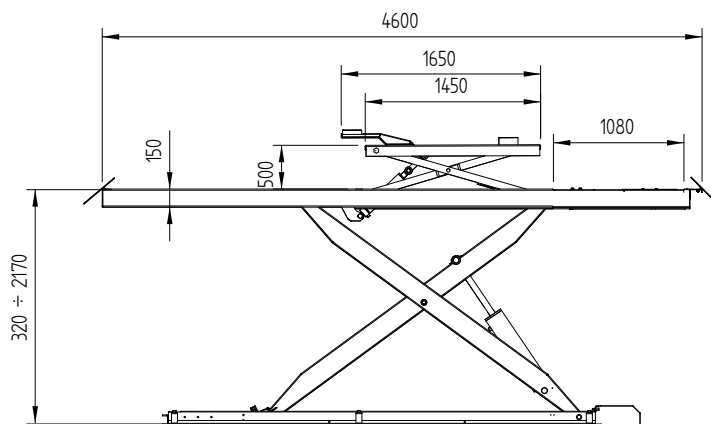
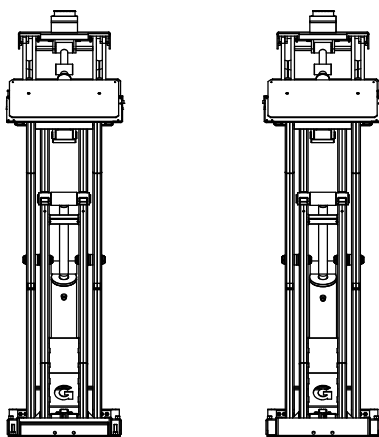



# GT - S 400 FLT 4960mm

FLAT VERSION - VERSIONE PIANA

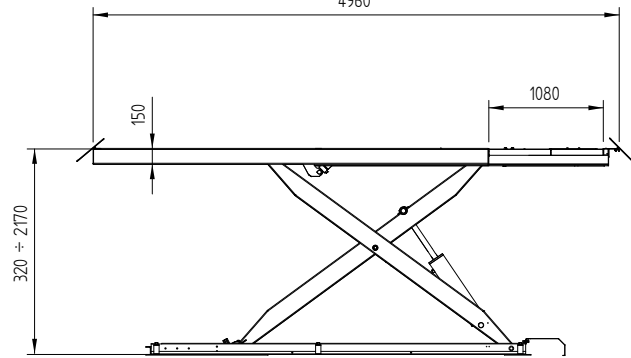
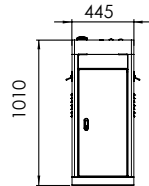
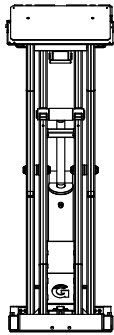
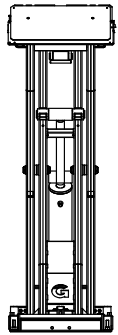
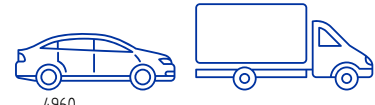

# GT - S 400 SFLT 4600mm

FLAT VERSION - VERSIONE PIANA

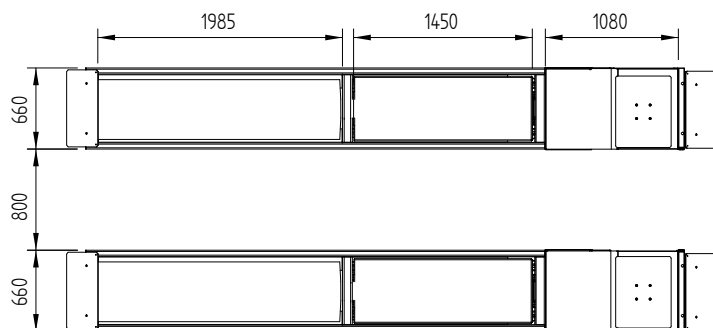
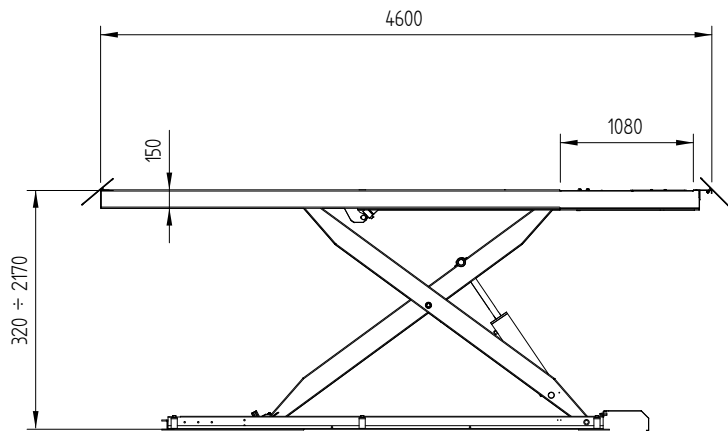
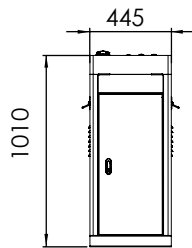
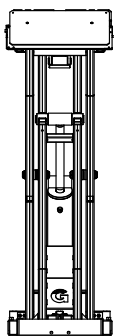
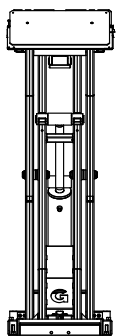
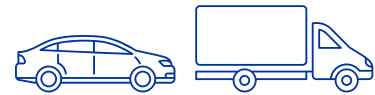

# GT - S 400 LT VERSION

4.000 Kg

- 1** HPD 6 MOVEMENTS (OPTIONAL)  
PROVAGIOCHI HPD 6 MOVIMENTI (OPTIONAL)
- 2** SLADING PLATES  
PIANI OSCILLANTI
- 3** TURNING PLATES (OPTIONAL)  
PIATTI ROTANTI (OPTIONAL)
- 4** APPROACHING RAMPS (ON FLOOR)  
RAMPE SALITA (A PAVIMENTO)
- 5** COVER FOR HOSES  
CARTER COPRITUBI
- 6** MECHANICAL SAFETY LOCK IN THE BASE  
SICURA MECCANICA SULLE BASI
- 7** LIFT TABLE EXTENSION CAPACITY 3.5 T  
ESTENSIONI LIFT TABLE CON PORTATA 3.5T
- 8** LIFT TABLE CAPACITY 3.5 TON  
CAPACITÀ DI SOLLEVAMENTO 3.5T

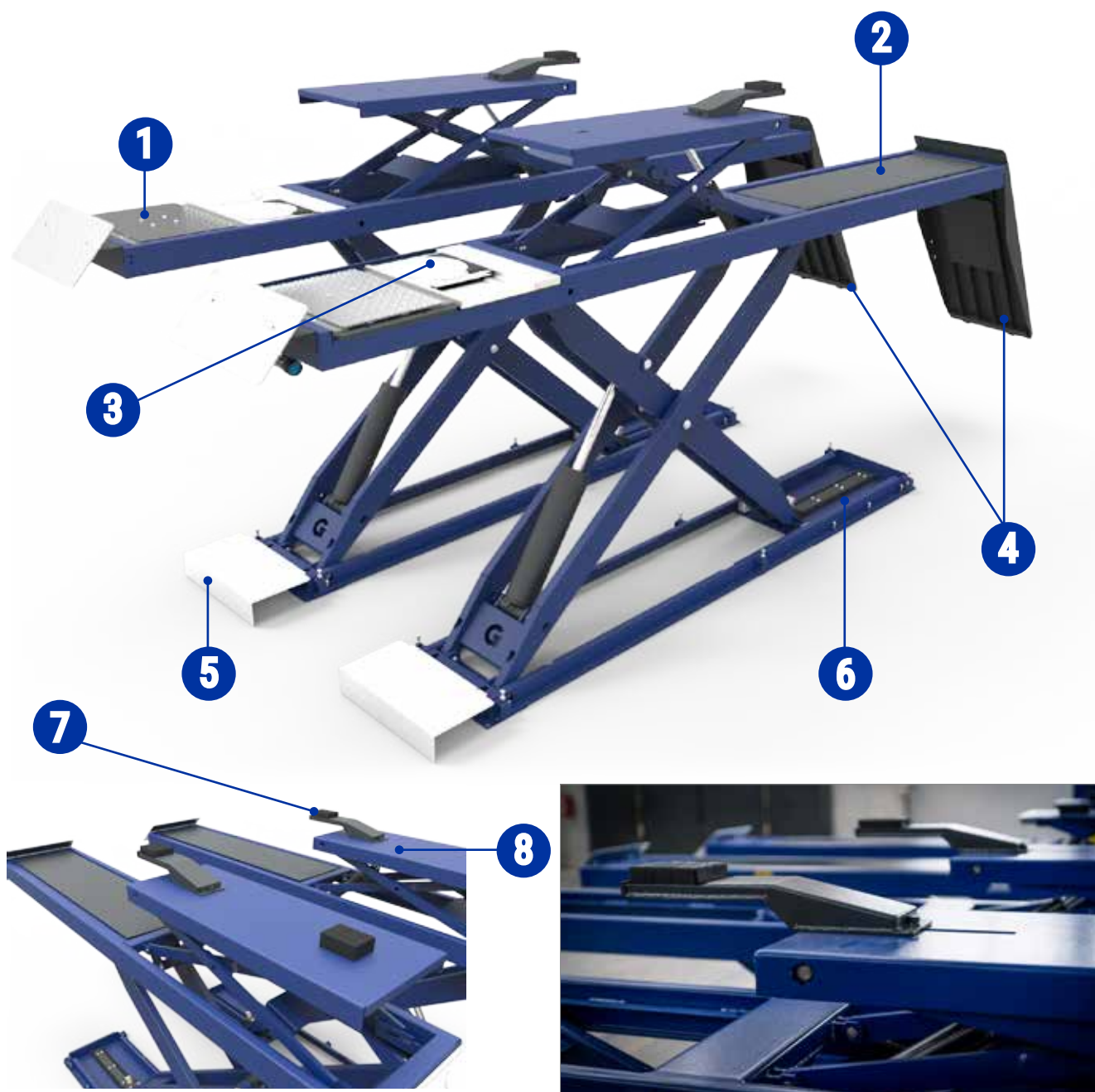

# GT - S 400 FLAT VERSION

4.000 Kg 

**1** COVER  
COVER

**3** HPD 6 MOVEMENTS (OPTIONAL)  
PROVAGIOCHI HPD 6 MOVIMENTI (OPTIONAL)

**2** APPROACHING RAMPS (ON FLOOR)  
RAMPE SALITA (ON FLOOR)

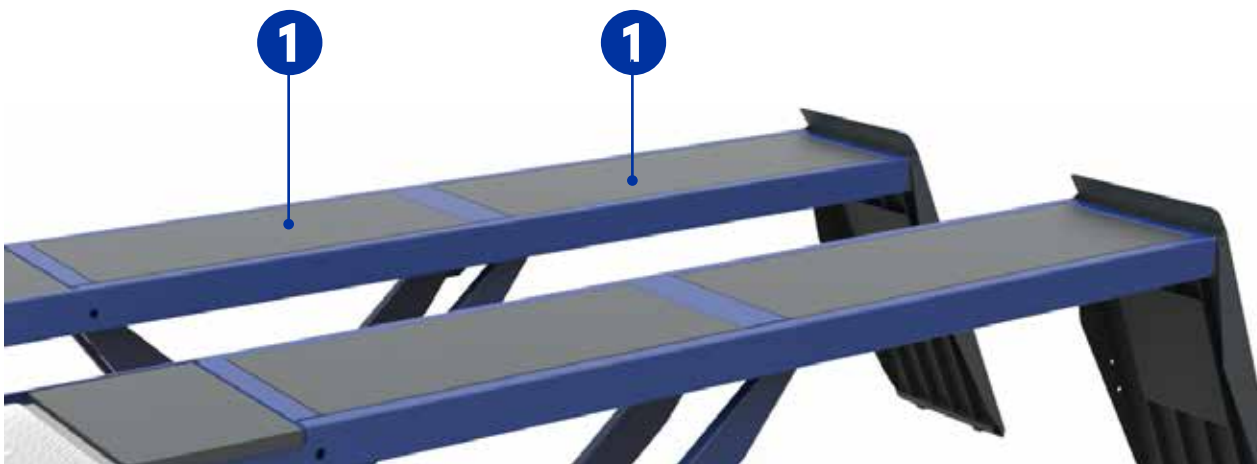
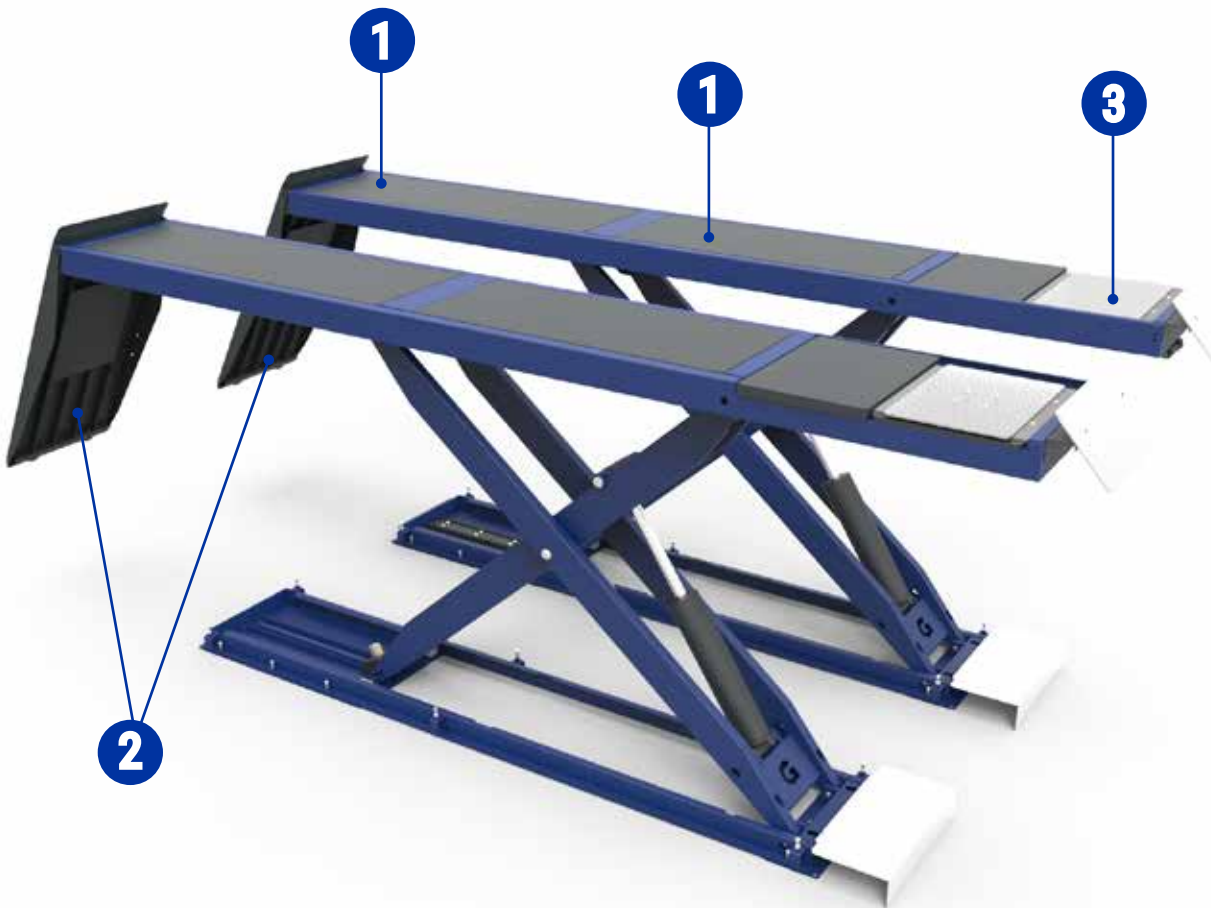



## GT - S 600



Electro- hydraulic scissor lift with automatic alignment - antiknock valves - main lift max lifting height 350 -2155 mm - LT max lifting height 425 mm - mechanical safety locks with pneumatic release (6/8 bar required) /engine power 2.6KW - 400V/3PH/50Hz. - INGROUND OR ON FLOOR VERSION (floor version on request with addition of up and down ramps cod.kit: A-93014)

Sollevatore a forbice elettroidraulico con allineamento automatico - valvole paracadute - Altezza di sollevamento 350 - 2155 mm - altezza sollevamento LT 425 mm - sicure a sgancio pneumatico - potenza motore 2.6KW - 400V/3PH/50Hz.

Richiesta connessione pneumatica per lo sgancio delle sicure 6/8 bar.- VERSIONE A INCASSO (versione a pavimento a richiesta con aggiunta di rampe salita e fermo ruota cod.kit: A-93014)



**6.000 Kg**



All models are equipped with 4 rubber pads. On request platforms on all models can host sliding plates, turning tables, rolling jacks.  
STANDARD PAINTING: BLU RAL 5002 - GREY RAL 7016

Tutti i modelli vengono forniti con 4 tamponi in gomma. A richiesta tutte le pedane possono ospitare piani oscillanti, piatti rotanti e rolling jack.  
COLORI STANDARD: BLU RAL 5002 - GRIGIO RAL 7016

MODEL	PLATFORM (mm)	LIFT CAPACITY	LT CAPACITY	DESCRIPTION
<b>GT-S 600 A</b>	5490 x 700	6.0 T	-	Sliding plates - front recess length 990 mm - central compartment with fixed cover - engine power 2.6 Kw - 400v/3ph/50Hz Piano oscillante - incavo anteriore lunghezza 990 mm - copertura fissa vano centrale - potenza motore 2.6 Kw - 400v/3ph/50Hz
<b>GT-S 600 ALT</b>	5490 x 700	6.0 T	3.5 T	Sliding plates - front recess length 990 mm - LT max lifting height 425 mm - engine power 2.6 Kw - 400v /3ph/50Hz Piano oscillante - incavo anteriore 990 mm - Lift Table altezza di sollevamento 425 mm - potenza motore 2.6 Kw - 400v/3ph/50Hz
<b>GT-S 600 F</b>	5490 x 700	6.0 T	-	Flat platforms - front recess length 990 mm with fixed cover - central and rear recess with fixed covers - engine power 2.6 Kw - 400v/3ph/50Hz Pedana piana - incavo anteriore lunghezza 990 mm con copertura fissa - copertura fissa vano centrale e copertura fissa vano piani oscillanti - potenza motore 2.6 Kw - 400v/3ph/50Hz
<b>GT-S 600 FLT</b>	5490 x 700	6.0 T	3.5 T	Flat platforms - front recess length 990 mm - with fixed covers - LT max lifting height lift 425 mm - rear compartment with fixed cover - engine power 2.6 Kw - 400v/3ph/50Hz Pedana piana - incavo anteriore lunghezza 990 mm con copertura fissa - Lift Table altezza di sollevamento 425 mm - copertura fissa vano piani oscillanti - potenza motore 2.6 Kw - 400v/3ph/50Hz
<b>GT-S 600 SA</b>	4960 x 700	6.0 T	-	Sliding plates - front recess length 990 mm - platform length 4960 mm - central recess with fixed cover- engine power 2.6 Kw - 400v/3ph/50Hz Piano oscillante - incavo anteriore lunghezza 990 mm - copertura fissa vano centrale - lunghezza pedana 4960mm - potenza motore 2.6 Kw - 400v/3ph/50Hz
<b>GT-S 600 SALT</b>	4960 x 700	6.0 T	3.5 T	Sliding plates - front recess length 990 mm - LT max lifting height 425 mm - platform length 4960 mm - engine power 2.6 Kw - 400v/3ph/50Hz Piano oscillante - incavo anteriore 990 mm - Lift Table altezza di sollevamento 425 mm - lunghezza pedana 4960mm - potenza motore 2.6 Kw - 400v/3ph/50Hz
<b>GT-S 600 SF</b>	4960 x 700	6.0 T	-	Flat platforms-front recess length 990 mm with fixed cover- central and rear compartment with fixed covers - platform length 4960mm - engine power 2.6 Kw/400v/3ph/50Hz Pedana piana - incavo anteriore lunghezza 990 mm con copertura fissa - copertura fissa vano centrale e copertura vano piani oscillanti - lunghezza pedana 4960 mm - potenza motore 2.6 Kw - 400v/3ph/50Hz
<b>GT-S 600 SFLT</b>	4960 x 700	6.0 T	3.5 T	Flat platforms-front recess length 990 mm with fixed covers- LT max lifting height 425 mm- rear fixed cover - platform length 4960mm - engine power 2.6 Kw/400v/3ph/50Hz Pedana piana - incavo anteriore lunghezza 990 mm con copertura fissa - Lift Table altezza di sollevamento 425 mm - copertura fissa vano piani oscillanti - lunghezza pedana 4960 mm - potenza motore 2.6 Kw - 400v/3ph/50Hz

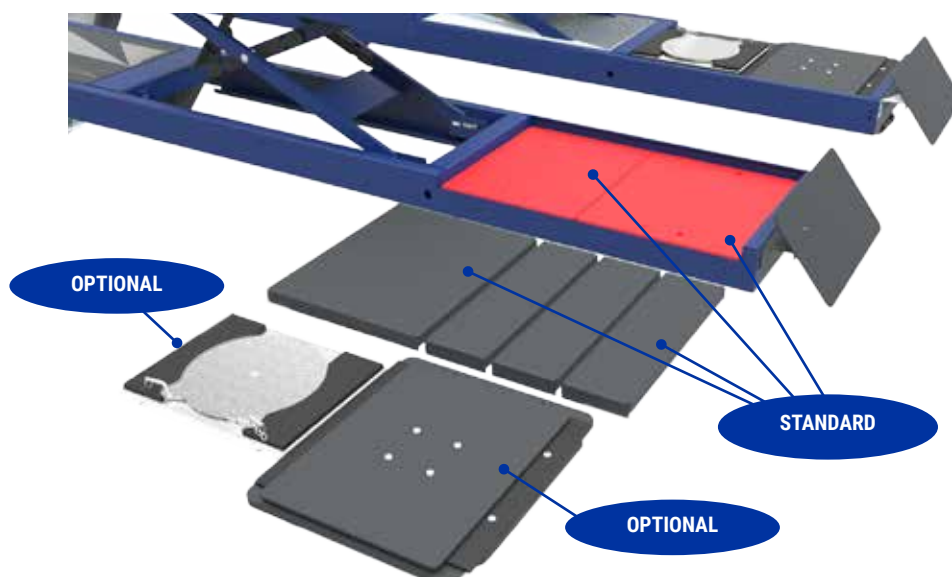

# S 600 LT VERSION

6.000 Kg

- 1** HPD 6 MOVEMENTS (OPRIONAL)  
PROVAGIOCHI HPD 6 MOVIMENTI (OPTIONAL)
- 2** SLADING PLATES  
PIANI OSCILLANTI
- 3** TURNING PLATES (OPTIONAL)  
PIATTO ROTANTE (OPTIONAL)
- 4** COVER FOR HOSES  
CARTER COPRITUBI
- 5** MECHANICAL SAFETY LOCK IN THE CYLINDER  
SICURA MECCANICA SUI CILINDRI
- 6** LIFT TABLE EXTENSION  
ESTENSIONE LIFT TABLE
- 7** LIFT TABLE CAPACITY 3.5 Ton  
LIFT TABLE CAPACITÀ 3.5 TON

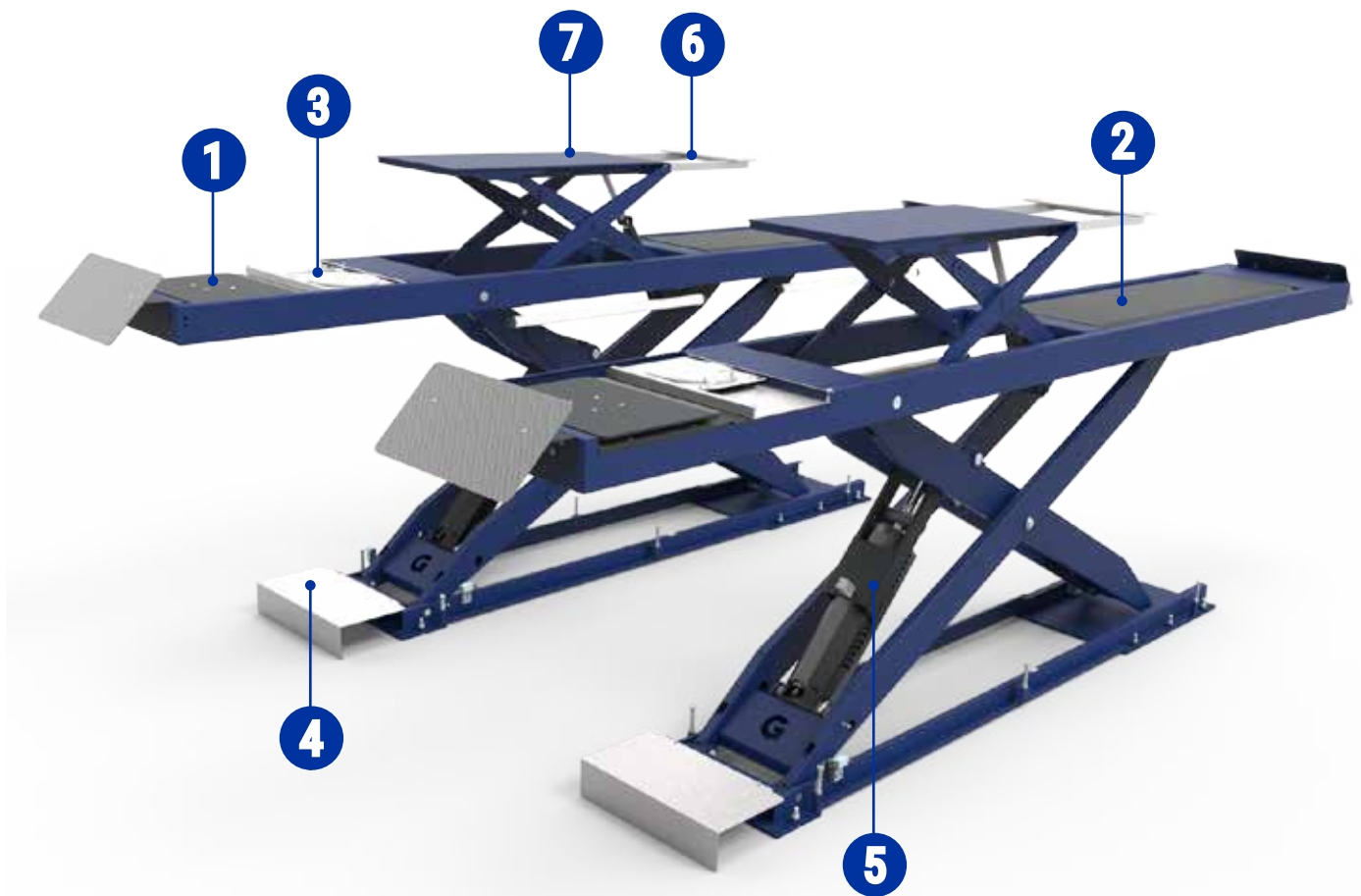



# S 600 FLAT VERSION

**6.000** Kg

- 1** COVER  
COVER
- 2** HPD 6 MOVEMENTS  
PROVAGIOCHI HPD 6 MOVIMENTI
- 3** COVER FOR HOSES  
CARTER COPRITUBI
- 4** MECHANICAL SAFETY LOCK IN THE CYLINDER  
SICURA MECCANICA SUI CILINDRI
- 5** TURNING PLATES (OPTIONAL)  
PIATTO ROTANTE (OPTIONAL)

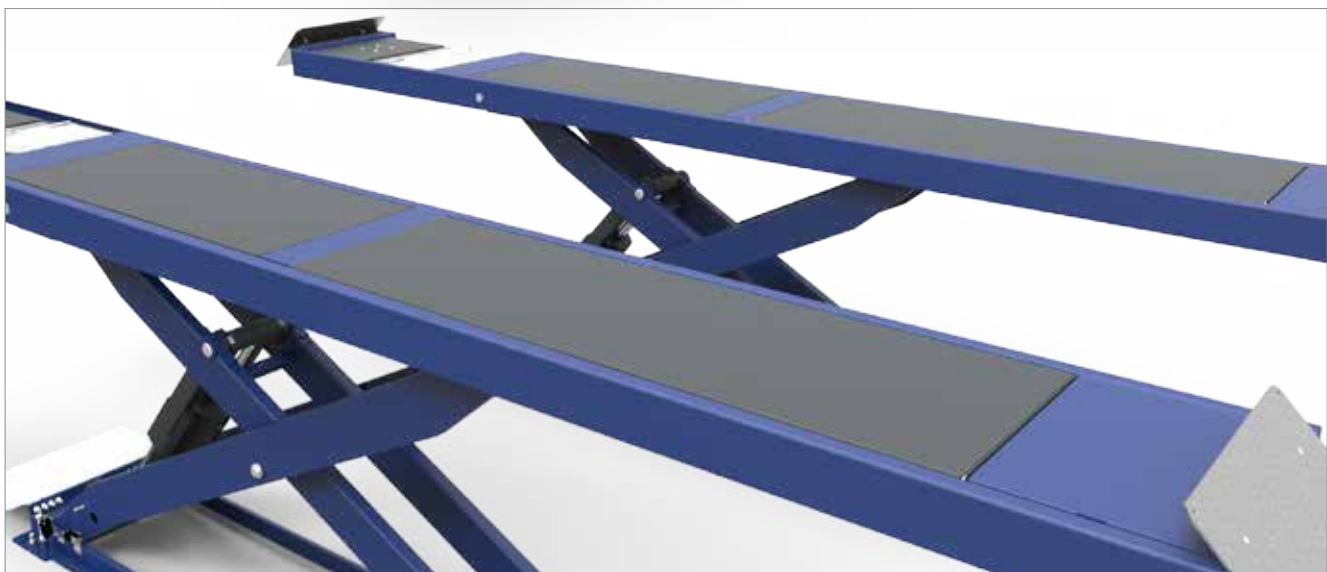
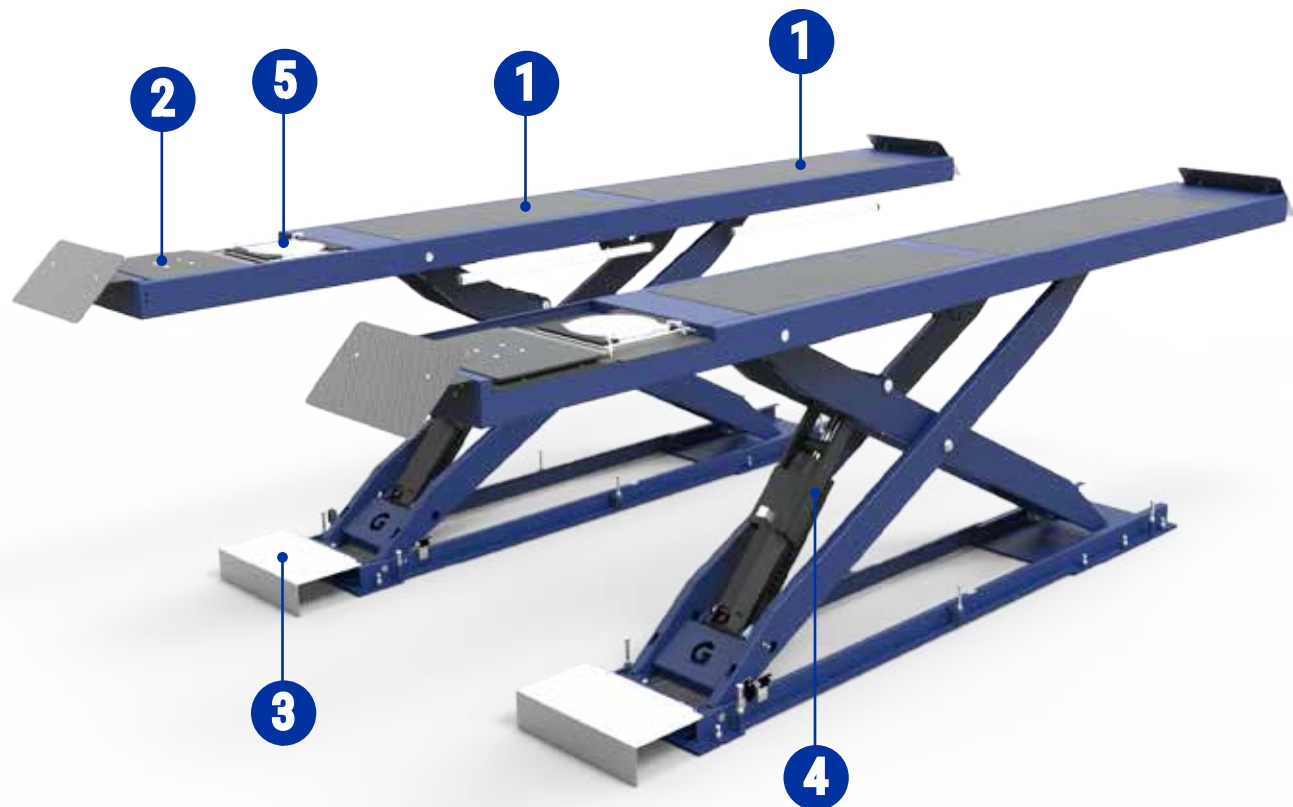

# GT - S 500 ALT

# GT - S 600 ALT

LT VERSION - VERSIONE CON TORRETTA

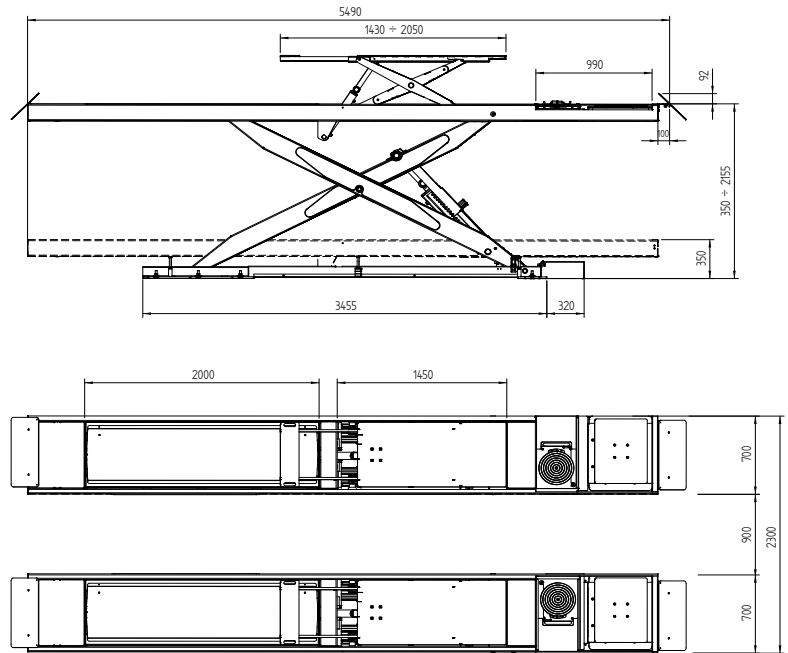
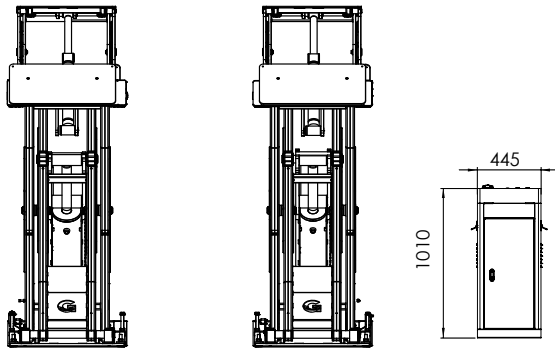

# GT - S 500 SALT

# GT - S 600 SALT

LT VERSION - PEDANA CORTA

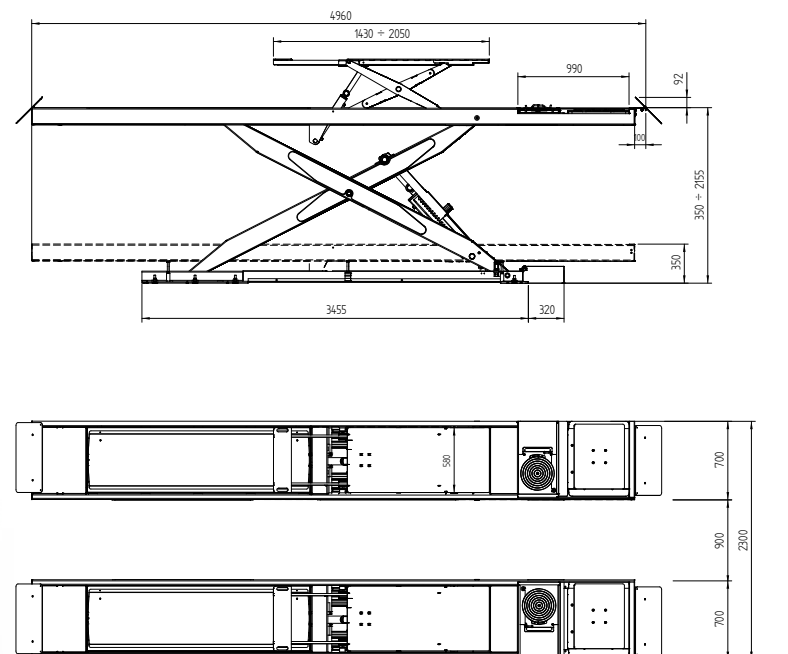
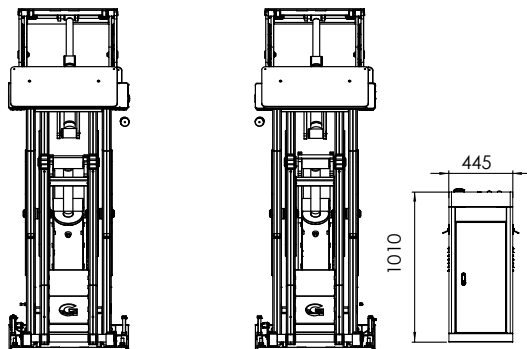

# GT - S 500 F

# GT - S 600 F

FLAT VERSION - VERSIONE PIANA

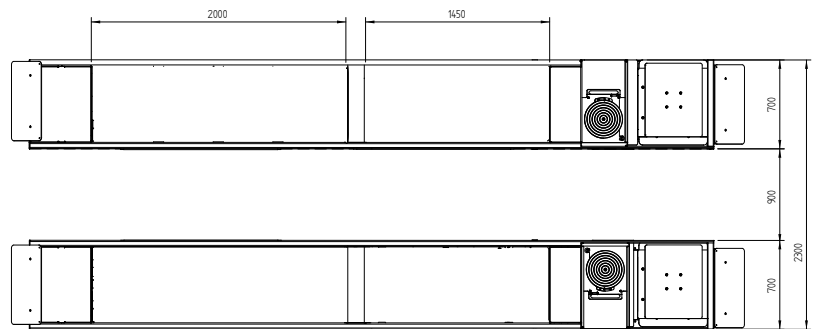
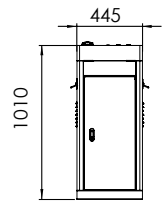
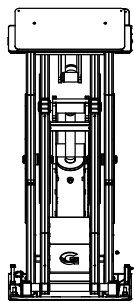
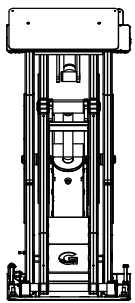
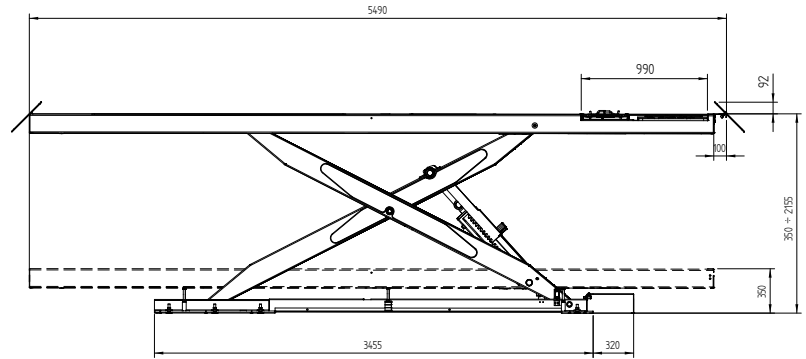
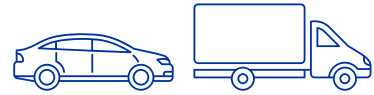

# GT - S 500 SFLT

# GT - S 600 SFLT

FLAT VERSION - VERSIONE PIANA/CORTA

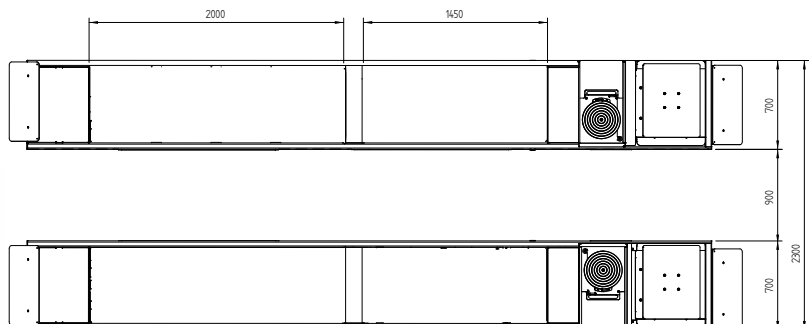
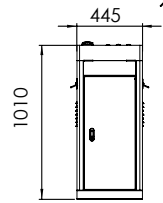
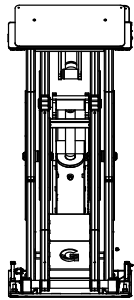
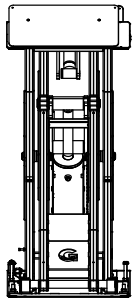
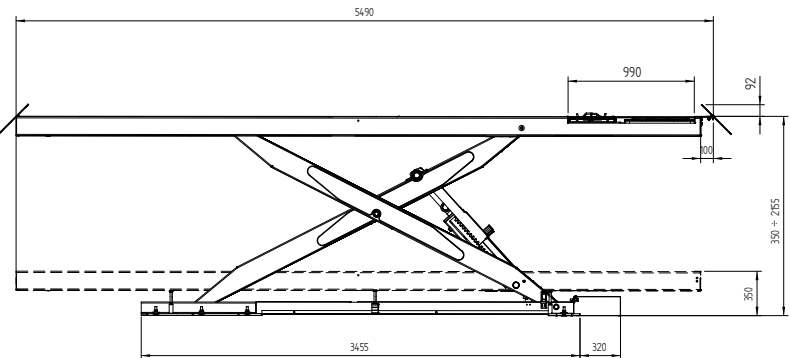



# OPTIONAL GT - S 600

CODE	DESCRIPTION				
<b>A-93013</b>	LED lamps 24 Volt - Set 4 lampade 24 Volt LED				
<b>A-93029</b>	Expansion bolts set (20 pz) - Set tasselli di fissaggio (20pz)				
<b>A-93015</b>	Approaching ramps on ground installation - Set rampe salita per versione a pavimento				
<b>A-93030</b>	Mobile Cover for HPD - Coperture MOBILE vano HPD				
<b>A-93031</b>	Mobile Cover for TURNING PLATES - Coperture MOBILE vano PIATTI ROTANTI				
<b>A-93019</b>	Set rubber pad H= 60 mm (4 pz) - Set tamponi H= 60 mm (4 pz)				
<b>A-93020</b>	Set rubber pad H= 120 mm (4 pz) - Set tamponi H= 120 mm (4 pz)				
<b>A-93024</b>	HPD 6 movements + spot light - HPD 6 movimenti + torcia				
<b>A-93032</b>	Turning plates set with covers - Set piatti rotanti con copertura				
<b>A-93021</b>	Wires-pipes extension set L= +1 m Set estensioni tubi-cavi L= +1 m	A	F	SA	SF
<b>A-93022</b>	Wires-pipes extension set L= +2 m Set estensioni tubi-cavi L= +2 m	A	F	SA	SF
<b>A-93023</b>	Wires-pipes extension set L= +3 m Set estensioni tubi-cavi L= +3 m	A	F	SA	SF
<b>A-93026</b>	Wires-pipes extension set L= +1 m Set estensioni tubi-cavi L= +1 m	ALT	FLT	SALT	SFLT
<b>A-93027</b>	Wires-pipes extension set L= +2 m Set estensioni tubi-cavi L= +2 m	ALT	FLT	SALT	SFLT
<b>A-93028</b>	Wires-pipes extension set L= +3 m Set estensioni tubi-cavi L= +3 m	ALT	FLT	SALT	SFLT
<b>A-93039</b>	Rubber ramps H=30mm Rampe in gomma H=30mm	ONLY FOR ON FLOOR VERSION / SOLO PER VERSIONE A PAVIMENTO			
<b>A-93040</b>	Rubber ramps H=50mm Rampe in gomma H=50mm	ONLY FOR ON FLOOR VERSION / SOLO PER VERSIONE A PAVIMENTO			

## TURNING PLATES-PIATTI ROTANTI

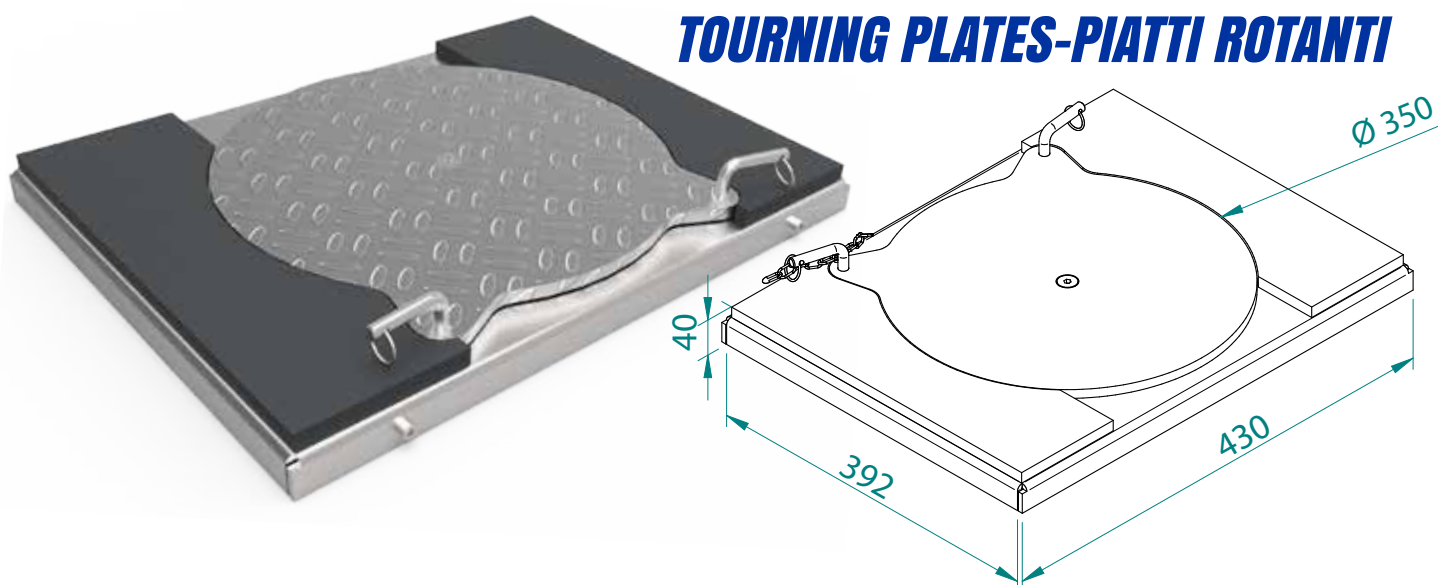



SLIDING PLATES  
PIANI OSCILLANTI



HPD 6 MOVEMENTS  
PROVAGIOCHI 6 MOVIMENTI



SLIDING PADS  
PATTINI DI SCORRIMENTO





## GT - S 500



Electro-hydraulic scissor lift with automatic alignment - antiknock valves - main lift max lifting height 350-2155 mm - LT max lifting height 425 mm - mechanical safety locks with pneumatic release (6/8 bar required) /engine power 2.6 KW - 400V/3PH/50Hz. INGROUND OR ON FLOOR VERSION (floor version on request with addition of up and down ramps cod.kit: A-93014)

Sollevatore a forbice elettroidraulico con allineamento automatico - valvole paracadute - Altezza di sollevamento 350 - 2155 mm - altezza sollevamento LT 425 mm - sicure a sgancio pneumatico - potenza motore 2.6KW - 400V/3PH/50Hz.

Richiesta connessione pneumatica per lo sgancio delle sicure 6/8 bar. VERSIONE A INCASSO (versione a pavimento a richiesta con aggiunta di rampe salita e fermo ruota cod.kit: A-93014)



**5.000 Kg**



All models are equipped with 4 rubber pads. On request platforms on all models can host sliding plates, turning tables, rolling jacks. STANDARD PAINTING: BLU RAL 5002 - GREY RAL 7016

Tutti i modelli vengono forniti con 4 tamponi in gomma. A richiesta tutte le pedane possono ospitare piani oscillanti, piatti rotanti e rolling jack. COLORI STANDARD: BLU RAL 5002 - GRIGIO RAL 7016

MODEL	PLATFORM (mm)	LIFT CAPACITY	LT CAPACITY	DESCRIPTION
<b>GT-S 500 A</b>	5490 x 700	5.0 T	-	Sliding plates - front recess length 990 mm - central compartment with fixed cover - engine power 2.6 Kw - 400v/3ph/50Hz Piano oscillante - incavo anteriore lunghezza 990 mm - copertura fissa vano centrale - potenza motore 2.6 Kw - 400v/3ph/50Hz
<b>GT-S 500 ALT</b>	5490 x 700	5.0 T	3.5 T	Sliding plates - front recess length 990 mm - LT max lifting height 425 mm - engine power 2.6 Kw - 400v /3ph/50Hz Piano oscillante - incavo anteriore 990 mm - Lift Table altezza di sollevamento 425 mm - potenza motore 2.6 Kw - 400v/3ph/50Hz
<b>GT-S 500 F</b>	5490 x 700	5.0 T	-	Flat platforms - front recess length 990 mm with fixed cover - central and rear recess with fixed covers - engine power 2.6 Kw - 400v/3ph/50Hz Pedana piana - incavo anteriore lunghezza 990 mm con copertura fissa - copertura fissa vano centrale e copertura fissa vano piani oscillanti - potenza motore 2.6 Kw - 400v/3ph/50Hz
<b>GT-S 500 FLT</b>	5490 x 700	5.0 T	3.5 T	Flat platforms - front recess length 990 mm - with fixed covers - LT max lifting height lift 425 mm - rear compartment with fixed cover - engine power 2.6 Kw - 400v/3ph/50Hz Pedana piana - incavo anteriore lunghezza 990 mm con copertura fissa - Lift Table altezza di sollevamento 425 mm - copertura fissa vano piani oscillanti - potenza motore 2.6 Kw - 400v/3ph/50Hz
<b>GT-S 500 SA</b>	4960 x 700	5.0 T	-	Sliding plates - front recess length 990 mm - platform length 4960 mm - central fixed full cover- engine power 2.6 Kw - 400v/3ph/50Hz Piano oscillante - incavo anteriore lunghezza 990 mm - copertura fissa vano centrale - lunghezza pedana 4960mm - potenza motore 2.6 Kw - 400v/3ph/50Hz
<b>GT-S 500 SALT</b>	4960 x 700	5.0 T	3.5 T	Sliding plates - front recess length 990 mm - LT max lifting height 425 mm - platform length 4960 mm - engine power 2.6 Kw - 400v/3ph/50Hz Piano oscillante - incavo anteriore 990 mm - Lift Table altezza di sollevamento 425 mm - lunghezza pedana 4960mm - potenza motore 2.6 Kw - 400v/3ph/50Hz
<b>GT-S 500 SF</b>	4960 x 700	5.0 T	-	Flat platforms-front recess length 990 mm with fixed cover- central and rear compartment with fixed covers - platform length 4960mm - engine power 2.6 Kw/400v/3ph/50Hz Pedana piana - incavo anteriore lunghezza 990 mm con copertura fissa - copertura fissa vano centrale e copertura vano piani oscillanti - lunghezza pedana 4960 mm - potenza motore 2.6 Kw - 400v/3ph/50Hz
<b>GT-S 500 SFLT</b>	4960 x 700	5.0 T	3.5 T	Flat platforms-front recess length 990 mm with fixed covers- LT max lifting height 425 mm- rear fixed cover - platform length 4960mm - engine power 2.6 Kw/400v/3ph/50Hz Pedana piana - incavo anteriore lunghezza 990 mm con copertura fissa - Lift Table altezza di sollevamento 425 mm - copertura fissa vano piani oscillanti - lunghezza pedana 4960 mm - potenza motore 2.6 Kw - 400v/3ph/50Hz

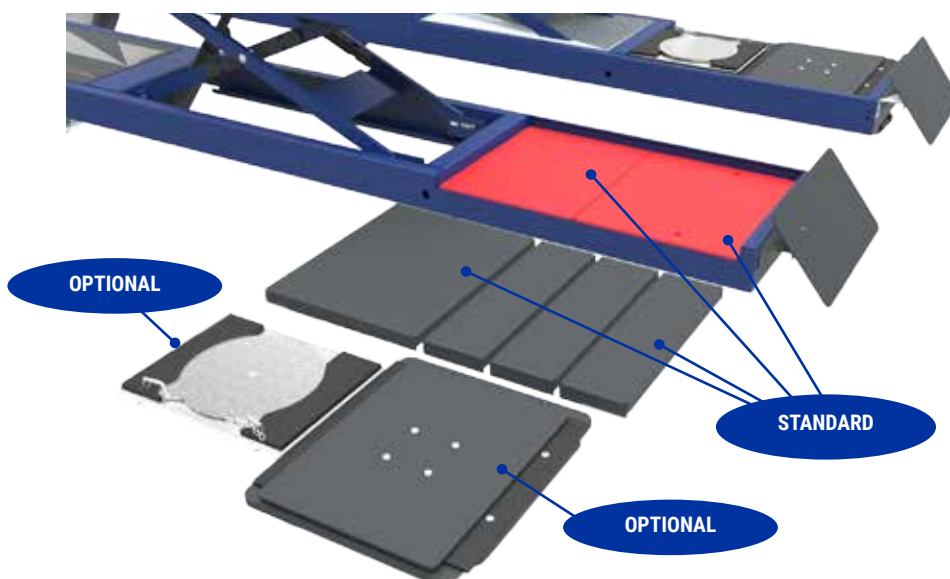

# OPTIONAL GT - S 500

CODE	DESCRIPTION				
<b>A-93013</b>	LED lamps 24 Volt - Set 4 lampade 24 Volt LED				
<b>A-93029</b>	Expansion bolts set (20 pz) - Set tasselli di fissaggio (20pz)				
<b>A-93015</b>	Approaching ramps on ground installation - Set rampe salita per versione a pavimento				
<b>A-93030</b>	Mobile Cover for HPD - Coperture MOBILE vano HPD				
<b>A-93031</b>	Mobile Cover for TURNING PLATES - Coperture MOBILE vano PIATTI ROTANTI				
<b>A-93019</b>	Set rubber pad H= 60 mm (4 pz) - Set tamponi H= 60 mm (4 pz)				
<b>A-93020</b>	Set rubber pad H= 120 mm (4 pz) - Set tamponi H= 120 mm (4 pz)				
<b>A-93024</b>	HPD 6 movements + spot light - HPD 6 movimenti + torcia				
<b>A-93032</b>	Turning plates set with covers - Set piatti rotanti con copertura				
<b>A-93021</b>	Wires-pipes extension set L= +1 m Set estensioni tubi-cavi L= +1 m	A	F	SA	SF
<b>A-93022</b>	Wires-pipes extension set L= +2 m Set estensioni tubi-cavi L= +2 m	A	F	SA	SF
<b>A-93023</b>	Wires-pipes extension set L= +3 m Set estensioni tubi-cavi L= +3 m	A	F	SA	SF
<b>A-93026</b>	Wires-pipes extension set L= +1 m Set estensioni tubi-cavi L= +1 m	ALT	FLT	SALT	SFLT
<b>A-93027</b>	Wires-pipes extension set L= +2 m Set estensioni tubi-cavi L= +2 m	ALT	FLT	SALT	SFLT
<b>A-93028</b>	Wires-pipes extension set L= +3 m Set estensioni tubi-cavi L= +3 m	ALT	FLT	SALT	SFLT
<b>A-93039</b>	Rubber ramps H=30mm Rampe in gomma H=30mm	ONLY FOR ON FLOOR VERSION / SOLO PER VERSIONE A PAVIMENTO			
<b>A-93040</b>	Rubber ramps H=50mm Rampe in gomma H=50mm	ONLY FOR ON FLOOR VERSION / SOLO PER VERSIONE A PAVIMENTO			





# GT - S 500



CONTROL UNIT  
CONTROL UNIT



4 LED LIGHTS  
4 LUCI A LED



RUBBER RAMPS H=30/50mm  
RAMPA IN GOMMA H=30/50mm



ROLLING JACK 2T / 3T  
ROLLING JACK 2T / 3T



APPROACHING RAMPS  
RAMPE SALITA

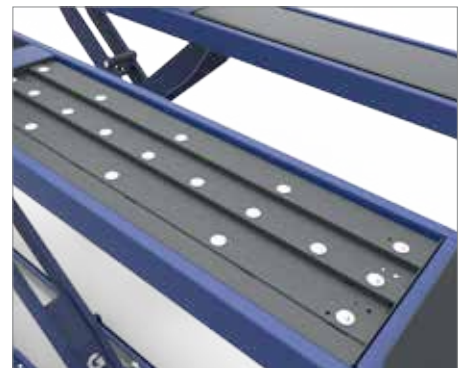

SLIDING PLATES  
PIANI OSCILLANTI



SPOT LIGHT HPD  
LAMPADA SPOT HPD



HPD 6 MOVEMENTS  
PROVA GIOCHI 6 MOVIMENTI

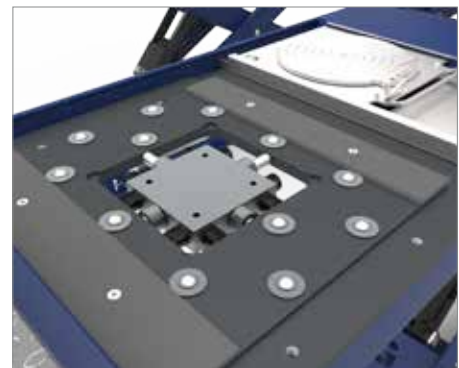

MECHANICAL SAFETY LOCK  
SICURA MECCANICA



SLIDING PAD  
PATTINI DI SCORRIMENTO



STANDARD LIFT TABLE  
STANDARD LIFT TABLE

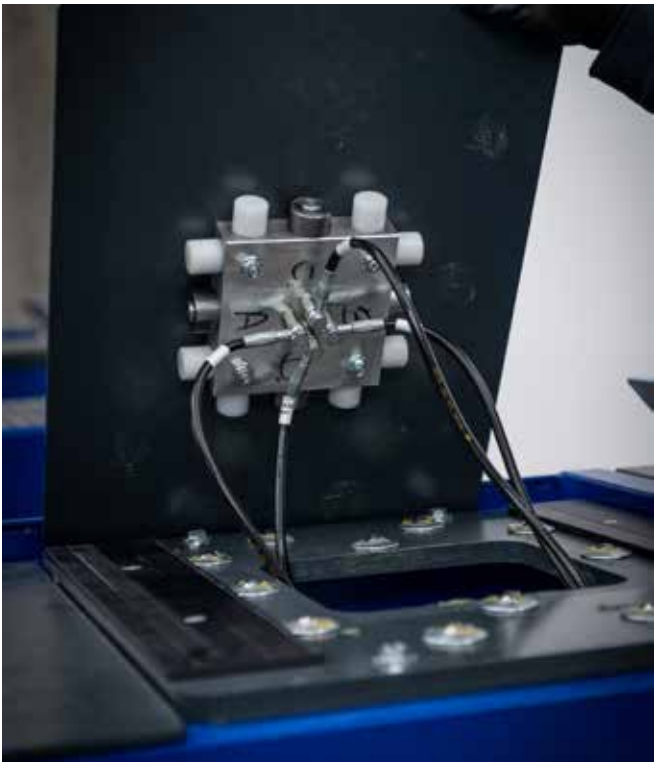







# GT - V 40



Two post lift with cross bar connection - hydraulic drive, 2 tracting cylinders directly connected to the carriages - mechanical safety lock with pneumatic release - standard engine power 2,6 KW - 400 V/3 PH/50 Hz - on request: 2,6 KW - 220 V/1 PH/50 Hz

Sollevatore elettroidraulico 2 colonne con traversa portante di collegamento - trasmissione idraulica, 2 cilindri in tiro connessi direttamente ai carrelli - sgancio sicuro pneumatico - sicure meccaniche - colonne asimmetriche - potenza motore 2,6 KW - 400V/3PH/50Hz - A richiesta: 2,6 KW - 220 V/1 PH/50 Hz

MODEL	CAPACITY	COLUMNS HIGHT	COLUMNS DISTANCE	LIFTING HIGHT	DESCRIPTION
<b>GT-V 40</b>	4.0 T	3870 mm (base)	2680	65 - 1940	2 post electro hydraulic lift with supporting crossbeam - short front extension arms (min 640/max 1200) - long rear extension arms (min 775/ max 1550) engine power 2.6kw - 400V/3PH Sollevatore elettroidraulico a 2 colonne con traversa portante - bracci anteriori corti a 2 sfill (min 640/max 1200) - bracci posteriori lunghi a 1 sfilo (min 775/max 1550). Potenza motore 2.6kw - 400V/3PH/50Hz
<b>GT-V 40 X</b>	4.0 T	4470 mm (+600mm)	2680	65 - 1940	2 post electro hydraulic lift with supporting crossbeam - short front extension arms (min 640/max 1200) - long rear extension arms (min 775/ max 1550) - engine power 2.6kw - 400V/3PH - Column extension 600mm Sollevatore elettroidraulico a 2 colonne con traversa portante - bracci anteriori corti a 2 sfill (min 640/max 1200) - bracci posteriori lunghi a 1 sfilo (min 775/max 1550) - Potenza motore 2.6kw - 400V/3PH/50Hz. Prolungamento colonna 600mm
<b>GT-V 40 XL</b>	4.0 T	5070 mm (+1200mm)	2680	65 - 1940	2 post electro hydraulic lift with supporting crossbeam - short front extension arms (min 640/max 1200) - long rear extension arms (min 775/ max 1550) - engine power 2.6kw - 400V/3PH - Column extension 1200mm Sollevatore elettroidraulico a 2 colonne con traversa portante - bracci anteriori corti a 2 sfill (min 640/max 1200) - bracci posteriori lunghi a 1 sfilo (min 775/max 1550) - Potenza motore 2.6kw - 400V/3PH/50Hz. Prolungamento colonna 1200 mm



EXTENSION COLUMN  
ESTENSIONI COLONNA



On request: 60mm / 160mm Extension kit  
STANDARD COLOURS: BLU RAL 5002 - GREY RAL 7016

A richiesta kit prolunghe 60mm / 160mm  
COLORI STANDARD: BLU RAL 5002 - GRIGIO RAL 7016

**1** EXTENSION PAD  
PROLUNGHE TAMPONE

**2** ASSIMETRICAL 2 SET ARMS  
2 SET DI BRACCI ASSIMMETRICI

**4.000 Kg**



SHORT ARM EXTENSION  
ESTENSIONE BRACCI CORTI



CONTROL PANEL  
QUADRO ELETTRICO

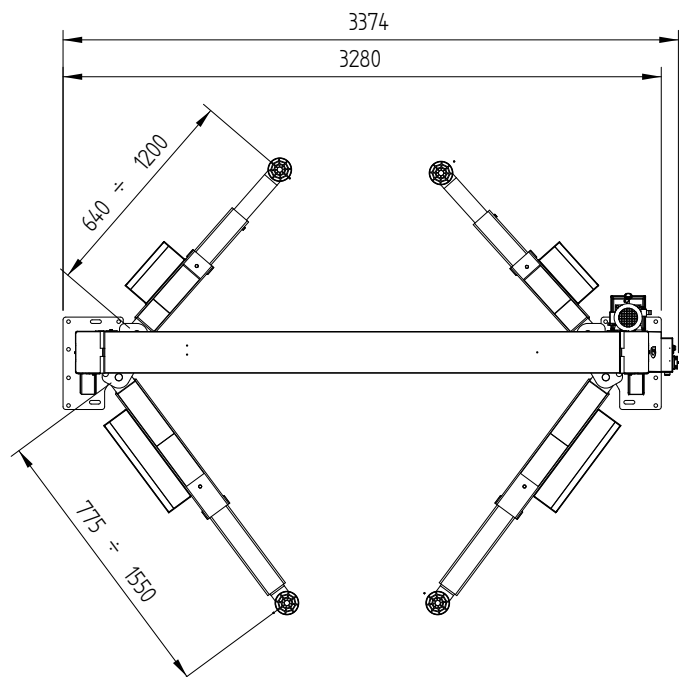
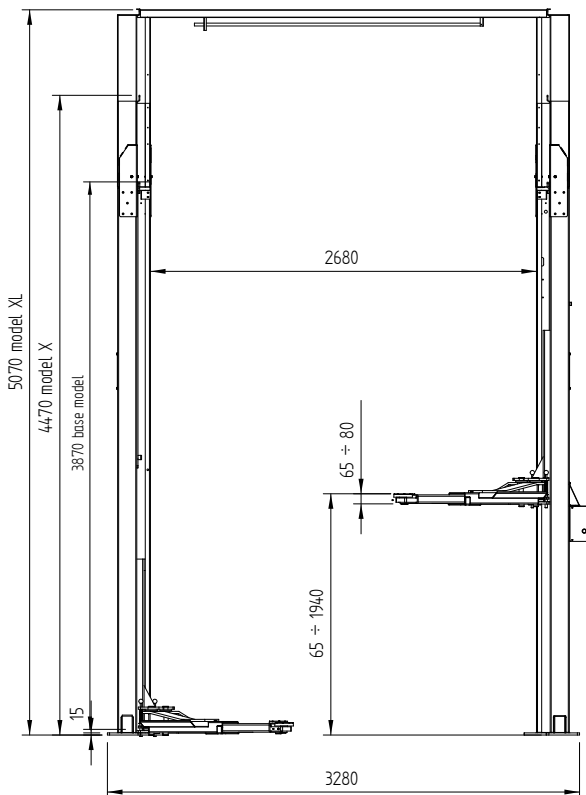

# GT - V 40M



Two post lift with cross bar connection - hydraulic drive, 2 tracting cylinders directly connected to the carriages - mechanical safety lock with **manual release** - standard engine power 2,6 KW - 400V/3 PH/50Hz - on request: 2,6 KW - 220 V/1 PH/50 Hz

Sollevatore elettroidraulico 2 colonne con traversa portante - trasmissione idraulica, 2 cilindri in tiro connessi direttamente ai carrelli - **sgancio sicure manuale** - sicure meccaniche - colonne assimetriche - potenza motore 2.6KW - 400V/3PH/50Hz - A richiesta: 2,6 KW - 220 V/1 PH/50 Hz

MODEL	CAPACITY	COLUMNNS HIGHT	COLUMNNS DISTANCE	LIFTING HIGHT	DESCRIPTION
<b>GT-V 40 M</b>	4.0 T	3870 mm (base)	2680	65 - 1940	2 post electro hydraulic lift with supporting crossbeam - short front extension arms (min 640/max 1200) - long rear extension arms (min 775/ max 1550) - engine power 2.6kw - 400V/3PH Sollevatore elettroidraulico a 2 colonne con traversa portante - bracci anteriori corti a 2 sfill (min 640/max 1200) - bracci posteriori lunghi a 1 sfilo (min 775/max 1550) - Potenza motore 2.6kw - 400V/3PH/50Hz
<b>GT-V 40 MX</b>	4.0 T	4470 mm (+600mm)	2680	65 - 1940	2 post electro hydraulic lift with supporting crossbeam - short front extension arms (min 640/max 1200) - long rear extension arms (min 775/ max 1550) - engine power 2.6kw - 400V/3PH - Column extension 600mm Sollevatore elettroidraulico a 2 colonne con traversa portante - bracci anteriori corti a 2 sfill (min 640/max 1200) - bracci posteriori lunghi a 1 sfilo (min 775/max 1550) - Potenza motore 2.6kw - 400V/3PH/50Hz. Prolungamento colonna 600mm
<b>GT-V 40 MXL</b>	4.0 T	5070 mm (+1200mm)	2680	65 - 1940	2 post electro hydraulic lift with supporting crossbeam - short front extension arms (min 640/max 1200) - long rear extension arms (min 775/ max 1550) - engine power 2.6kw - 400V/3PH - Column extension 1200mm Sollevatore elettroidraulico a 2 colonne con traversa portante - bracci anteriori corti a 2 sfill (min 640/max 1200) - bracci posteriori lunghi a 1 sfilo (min 775/max 1550) - Potenza motore 2.6kw - 400V/3PH/50Hz. Prolungamento colonna 1200 mm



EXTENSION COLUMN  
ESTENSIONI COLONNA



On request: 60mm / 160mm Extension kit  
STANDARD COLOURS: BLU RAL 5002 - GREY RAL 7016

A richiesta kit prolunghe 60mm / 160mm  
COLORI STANDARD: BLU RAL 5002 - GRIGIO RAL 7016



- 1** EXTENSION PAD  
PROLUNGHE TAMPONE
- 2** 2 ASSIMETRICAL ARMS  
2 SET DI BRACCI ASSIMMETRICI
- 3** MANUAL SAFE RELEASE  
SGANCIO MANUALE SICURE

**4.000 Kg**

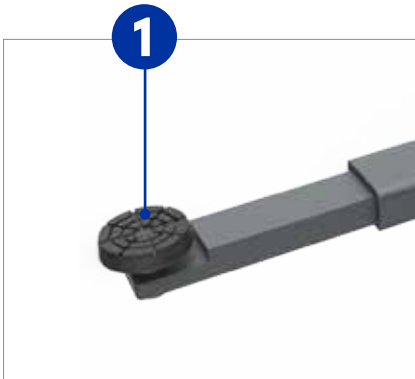
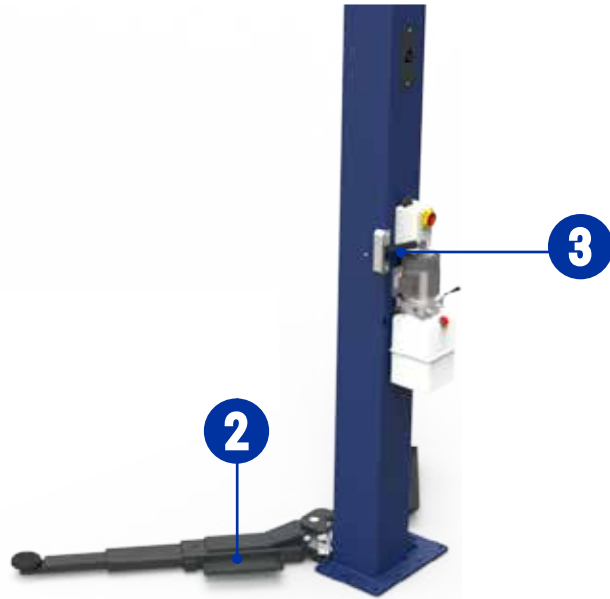

**1**  
SHORT ARM EXTENSION  
ESTENSIONE BRACCI CORTI



**3**  
CONTROL BOX / MANUAL SAFE RELEASE  
QUADRO ELETTRICO / SGANCIO SICURA MANUALE

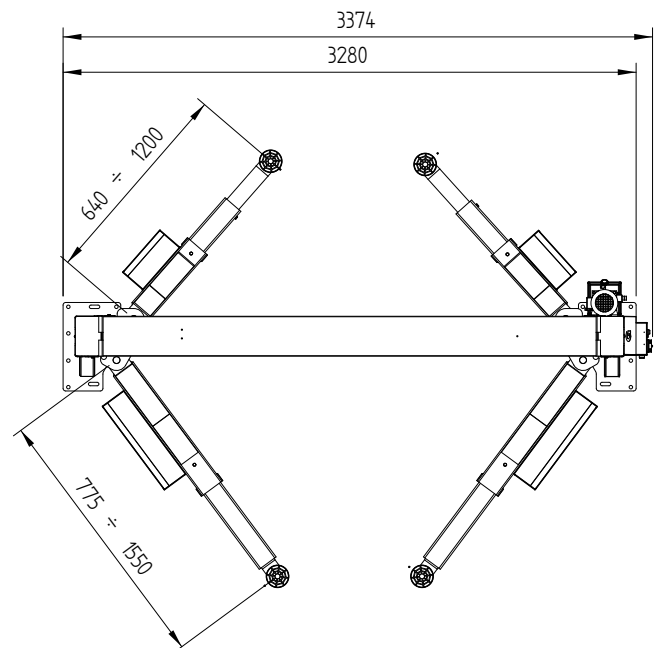
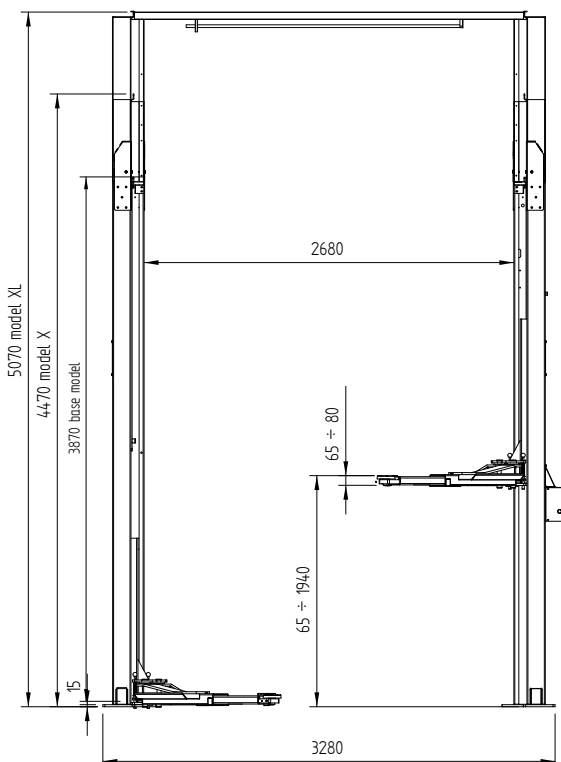

**OPTIONAL**

CODE	DESCRIPTION	V 40	V 40 X	V 40 XL	V 40 M	V 40 MX	V 40 MXL
<b>A-93013</b>	Ascent stop bar kit Kit barra di sicurezza arresto salita				*	*	*
<b>A-93014</b>	Expansion bolts set (14 pz) Set tasselli di fissaggio (14 pz)	*	*	*	*	*	*
<b>A-93012</b>	Predisposition Emergency pump Predisposizione pompa emergenza	*	*	*	*	*	*
<b>M9613201</b>	Emergency manual descent pump Pompa manuale discesa emergenza	*	*	*	*	*	*
<b>A-93001</b>	Extension columns set H= 600 Set estensione colonna H= 600	*					
<b>A-93002</b>	Extension columns set H= 1200 Set estensione colonna H= 1200	*					
<b>A-93003</b>	Extension columns set H= 600 Set estensione colonna H= 600				*		
<b>A-93004</b>	Extension columns set H= 1200 Set estensione colonna H= 1200				*		
<b>A-93007</b>	Kit for vehicle 4WD Kit 4 tamponi speciali per veicoli 4WD	*	*	*	*	*	*
<b>A-93008</b>	Adaptator for Mercedes - Iveco = 105 Adattatori per Mercedes - Iveco = 105	*	*	*	*	*	*
<b>A-93009</b>	Adaptator for Mercedes - Iveco =135 Adattatori per Mercedes - Iveco =135	*	*	*	*	*	*
<b>A-93036</b>	Kit Fixing bars Kit barre di fissaggio	*	*	*	*	*	*
<b>A-93033</b>	Kit extension pad + brackets Kit prolunghe tampone + staffe	*	*	*	*	*	*
<b>A-93041</b>	Anticollision kit Kit barra anticollisione				*	*	*

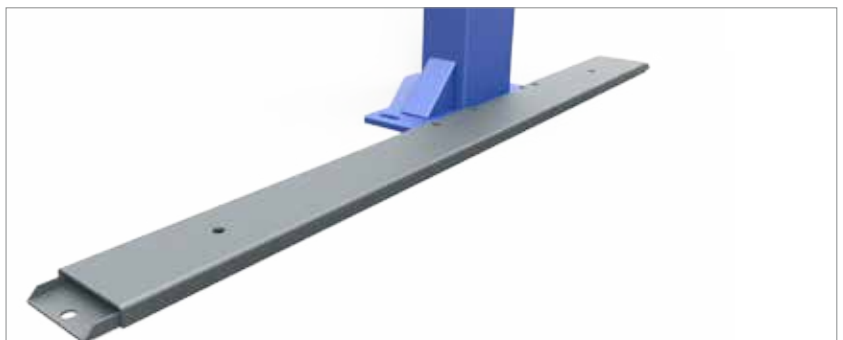
IVECO-MERCEDES ADAPTATORS  
ADATTATORI MERCEDES-IVECOFIXING BARS FOR DUMP FLOOR  
SET BARRE PER FISSAGGIO COLONNE SU PAVIMENTO DEBOLE

**GALTA**

**CAPACITY**  
**4000 kg**



AVVERTENZE GENERALI PER L'USO  
1. EVITARE CARICHI ECCESSIVI  
2. NON CARICARE SU PUNTI NON PREVISTI  
3. NON CARICARE SU PUNTI NON PREVISTI  
4. NON CARICARE SU PUNTI NON PREVISTI  
5. NON CARICARE SU PUNTI NON PREVISTI  
6. NON CARICARE SU PUNTI NON PREVISTI  
7. NON CARICARE SU PUNTI NON PREVISTI  
8. NON CARICARE SU PUNTI NON PREVISTI  
9. NON CARICARE SU PUNTI NON PREVISTI  
10. NON CARICARE SU PUNTI NON PREVISTI

**GALTA**  
Via Vittorio Lombardi 18/21  
36075 Montebelluna Maggiore (VI) Italy  
Tel.: +39 0444 483877 P.V.M. 0465700448

Emergency stop button, power button, directional control knob, and safety labels (400 VOLT, lightning bolt, person being struck).





# GT - V 40

- 1** ANTI COLLISION BAR  
BARRA ANTI COLLISIONE
- 2** TRACTION CYLINDERS  
CILINDRI IN TRAZIONE
- 3** ASYMMETRICAL COLUMNS  
COLONNE ASSIMETRICHE
- 4** PNEUMATIC SAFETY RELEASE  
SGANCIO SICURE PNEUMATICO

**4.000 Kg**

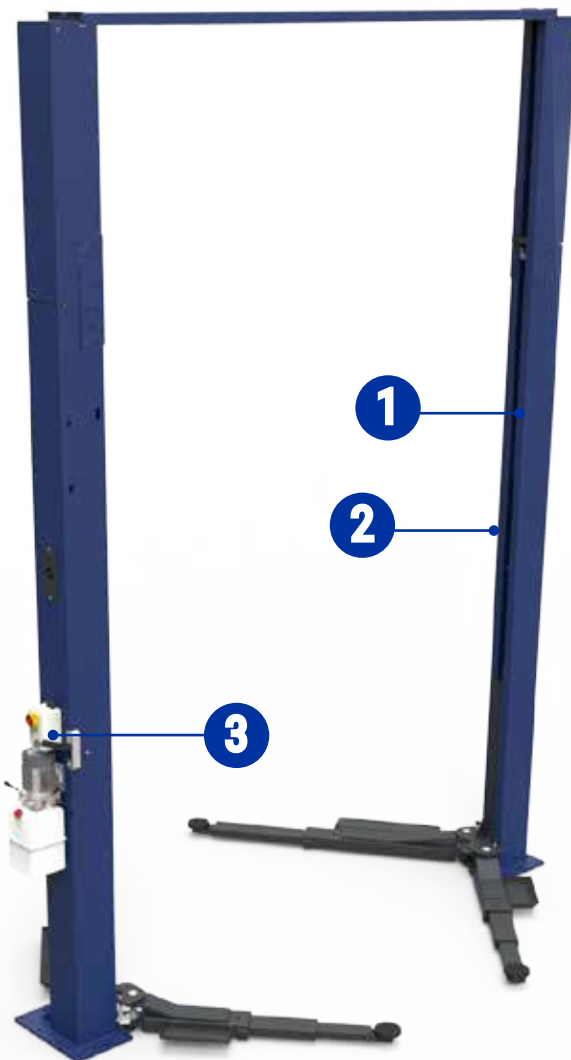

# GT - V 40 M

- 1** TRACTION CYLINDERS  
CILINDRI IN TRAZIONE
- 2** ASYMMETRICAL COLUMNS  
COLONNE ASSIMETRICHE
- 3** MANUAL SAFETY RELEASE  
SGANCIO SICURE MANUALE

**4.000 Kg**

# GT - V 50



Two post lift with upper connection, hydraulic drive - 2 tracting cylinders directly connected to the carriages - mechanical safety lock with electromagnetic release - standard engine power 2,6 KW - 400 V/3 PH/50 Hz

Sollevatore elettroidraulico 2 colonne con connessione aerea, trasmissione idraulica - 2 cilindri in tiro connessi direttamente ai carrelli - sgancio sicure elettromagnetico - sicure meccaniche - colonne simmetriche - potenza motore 2,6 KW - 400V/3PH/50Hz

MODEL	CAPACITY	COLUMNS HIGHT	COLUMNS DISTANCE	LIFTING HIGHT	DESCRIPTION
<b>GT-V 50</b>	5.0 T	3870 mm (base)	3100	95 - 2050	2 post electrohydraulic lift with supporting crossbeam - 2 stages arms (min 860/max 1700) - engine power 2.6kw - 400V/3PH Sollevatore elettroidraulico a 2 colonne con traversa portante - bracci a 2 sfill (min 860/max 1700) - Potenza motore 2.6 kw - 400V/3PH/50Hz
<b>GT-V 50 X</b>	5.0 T	4470 mm (+600mm)	3100	95 - 2050	2 post electrohydraulic lift with supporting crossbeam - 2 stages arms (min 860/max 1700) - engine power 2.6kw - 400V/3PH Column extension 600mm Sollevatore elettroidraulico a 2 colonne con traversa portante - bracci a 2 sfill (min 860/max 1700) - Potenza motore 2.6 kw - 400V/3PH/50Hz. Prolungamento colonna 600mm
<b>GT-V 50 XL</b>	5.0 T	5070 mm (+1200mm)	3100	95 - 2050	2 post electrohydraulic lift with supporting crossbeam - 2 stages arms (min 860/max 1700) - engine power 2.6kw - 400V/3PH. Column extension 1200 mm Sollevatore elettroidraulico a 2 colonne con traversa portante - bracci a 2 sfill (min 860/max 1700) - Potenza motore 2.6 kw - 400V/3PH/50Hz. Prolungamento colonna 1200 mm

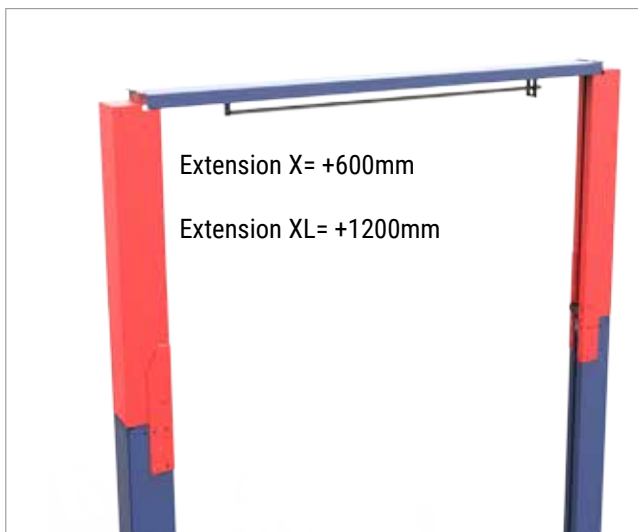

EXTENSION COLOUMN  
ESTENSIONI COLONNA



CONTROL BOX  
QUADRO ELETTRICO

Standard: 60mm / 160mm Extension kit  
STANDARD COLOURS: BLU RAL 5002 - GREY RAL 7016

Standard kit prolunghe 60mm / 160mm  
COLORI STANDARD: BLU RAL 5002 - GRIGIO RAL 7016



# OPTIONAL

CODE	DESCRIPTION	V50	V50 X	V50 XL
<b>A-93011</b>	Expansion bolts set (16 pz) Set tasselli di fissaggio (16 pz)	*	*	*
<b>A-93012</b>	Predisposition emergency pump Predisposizione pompa emergenza	*	*	*
<b>M9613201</b>	Emergency manual descent pump Pompa manuale discesa emergenza	*	*	*
<b>A-93005</b>	Extension columns set H= 600 Set estensione colonna H= 600	*		
<b>A-93006</b>	Extension columns set H= 1200 Set estensione colonna H= 1200	*		
<b>A-93007</b>	Kit for vehicle 4WD Kit 4 tamponi speciali per veicoli 4WD	*	*	*
<b>A-93008</b>	Adaptator for Mercedes - Iveco= 105 Adattatori per Mercedes - Iveco= 105	*	*	*
<b>A-93009</b>	Adaptator for Mercedes - Iveco= 135 Adattatori per Mercedes - Iveco= 135	*	*	*
<b>A-93033</b>	Kit extension pad + brackets Kit prolunghe tampone + staffe	*	*	*

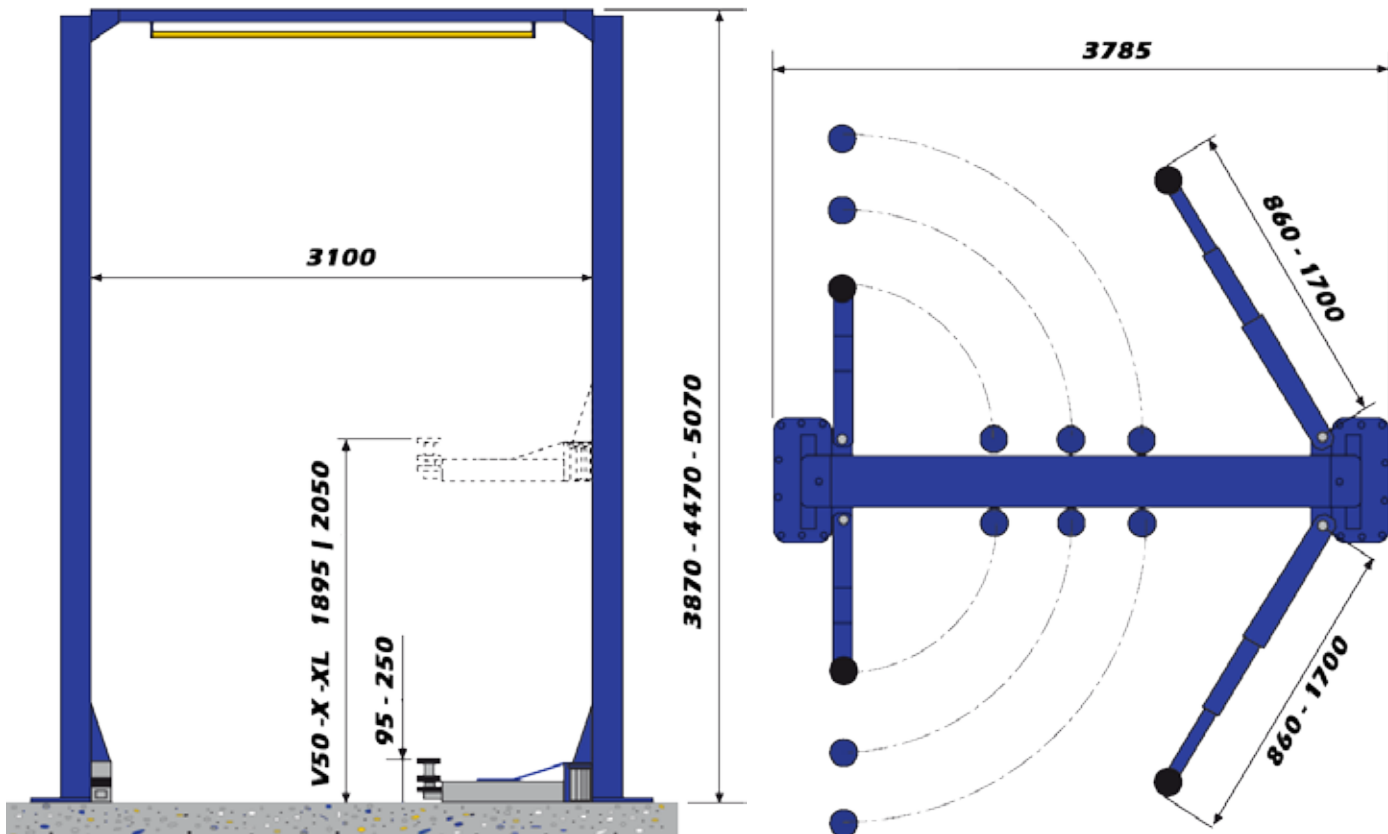

# GT - V 50



MERCEDES/IVECO ADAPTORS  
ADATTATORI MERCEDES/IVECO



EXTENSION ARMS  
ESTENSIONE BRACCI



RUBBER PAD  
TAPPONE IN GONNE



MECHANICAL SAFETY LOCK  
SICURA MEC. IN ACCIAIO SPECIALE





GALTIA

GALTIA

GALTIA

GALTIA





- 1** ANTI COLLISION BAR  
BARRA ANTI COLLISIONE
- 2** EXTENSIONS COLUMNS  
PROLUNGHE COLONNE
- 3** SYMMETRICAL COLUMNS  
COLONNE SIMMETRICHE
- 4** EXTENSIONS PAD  
PROLUNGHE TAMPONE
- 5** ELECTROMAGNETIC SAFETY RELEASE  
SGANCIO SICURE ELETTROMAGNETICO
- 6** DOUBLE EXTENSIONS ARMS  
BRACCI A DOPPIO SFILÒ



**5.000 Kg**

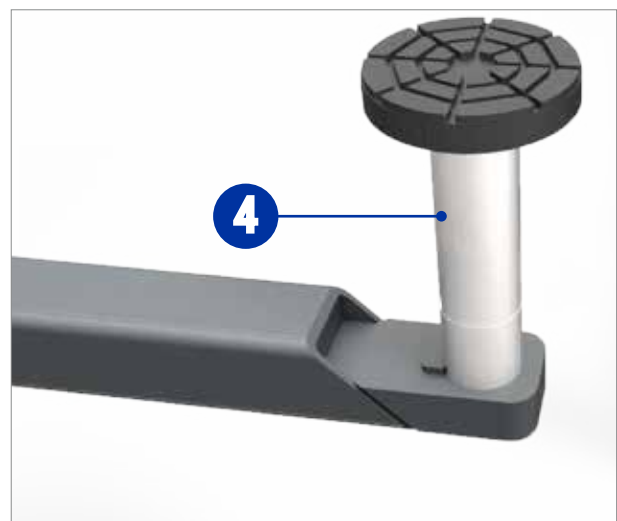
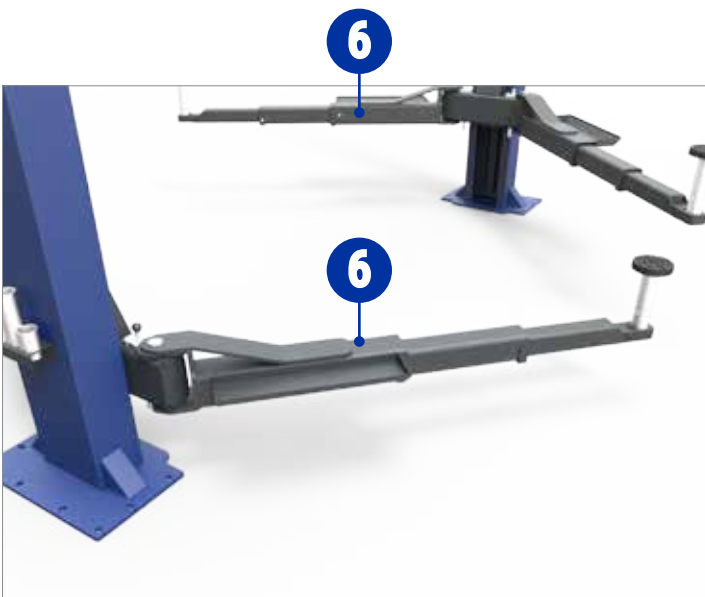

# GT - EM 2.8



2-column electro-mechanical lift with bearing base - chain drive - 1 motor - mechanical safety - 3.6 kw motor power - 400V / 3PH / 50Hz - on request 3.6 kw - 230V / 1PH / 50Hz

Sollevatore elettro-meccanico 2 colonne con basamento portante - trasmissione a catena - 1 motore - sicure meccaniche - potenza motore 3.6 KW - 400V/3PH/50Hz - A richiesta 3.6 KW - 230V/1PH/50Hz

MODEL	CAPACITY	COLUMN (mm)	COLUMN HIGHT	LIFTING HIGHT	DESCRIPTION
GT- EM 2.8	2.8 T	2512	2560	100-1945	Electro-mechanical lift 2 columns with base load-bearing - short front extension arms (960 mm) - long rear extension arms ( 1300 mm) Sollevatore elettro-meccanico 2 colonne con basamento portante - bracci anteriori corti a soppio sfilo (960 mm) - bracci posteriori lunghi a doppio sfilo (1300 mm)

**2.800** Kg



**GALTA**





# OPTIONAL

CODE	DESCRIPTION
------	-------------

**B-93014** Expansion bolts set (8 pz) - Set tasselli di fissaggio (8 pz)

**A-93033** Extension pad kit - Kit prolunghe tamponi 60mm - 160mm

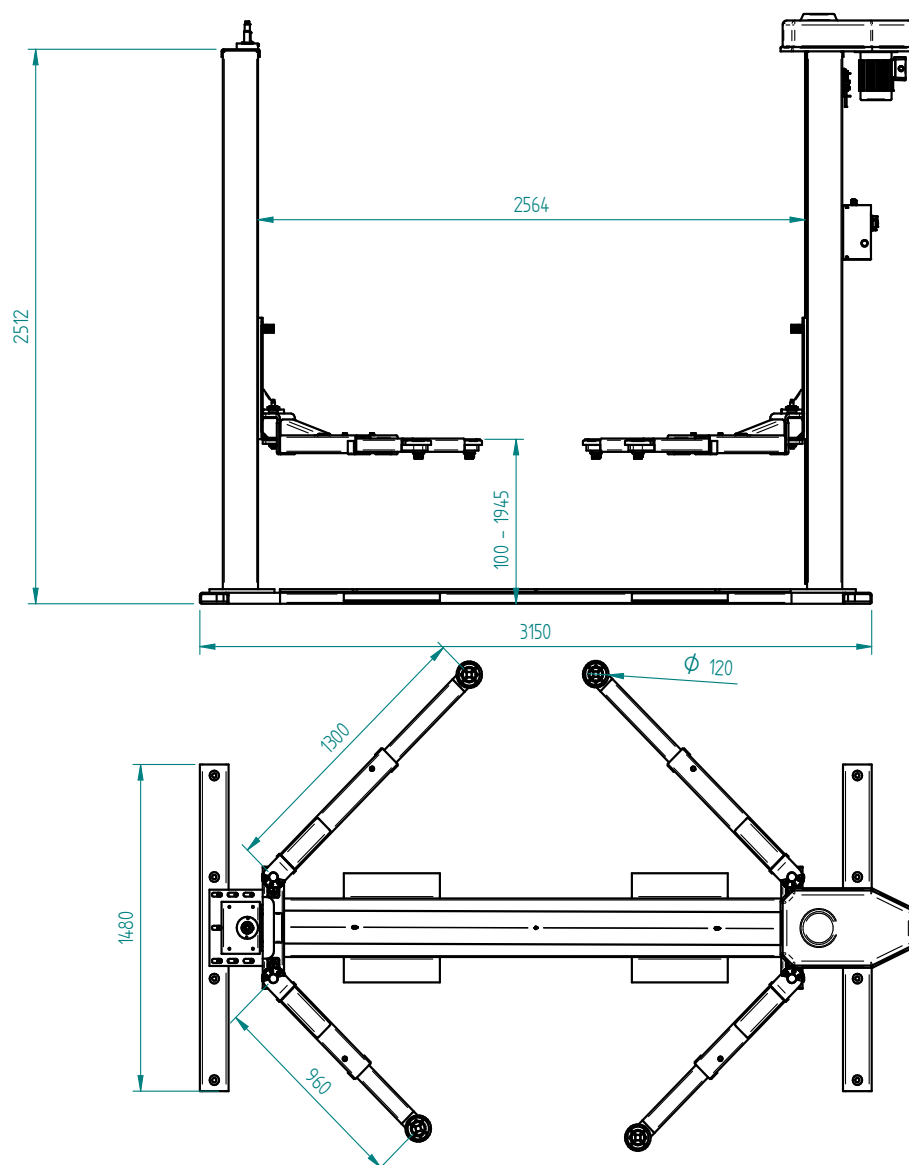

On request: 60mm / 160mm Extension kit  
STANDARD COLOURS: BLU RAL 5002 - GREY RAL 7016

A richiesta kit prolunghe : 60mm / 160mm  
COLORI STANDARD: BLU RAL 5002 - GRIGIO RAL 7016

# GT - EM 3.2



2-column electro-mechanical lift with bearing base - chain drive - 1 motor - mechanical safety - 3.6 kw motor power - 400V / 3PH / 50Hz - on request 3.6 kw - 230V / 1PH / 50Hz

Sollevatore elettro-meccanico 2 colonne con basamento portante - trasmissione a catena - 1 motore - sicure meccaniche - potenza motore 3.6 KW - 400V/3PH/50Hz - A richiesta 3.6 KW - 230V/1PH/50Hz

MODEL	CAPACITY	COLUMN (mm)	COLUMN HIGHT	LIFTING HIGHT	DESCRIPTION
GT- EM 3.2	3.2 T	2512	2560	115-1945	Electro-mechanical lift 2 columns with base load-bearing - short front extension arms (760mm) - long rear extension arms ( 1160 mm) Sollevatore elettro-meccanico 2 colonne con basamento portante - bracci anteriori corti (min 760) - bracci posteriori lunghi (1160)

**3.200 Kg**



# OPTIONAL

CODE	DESCRIPTION
<b>B-93014</b>	Expansion bolts set (8 pz) - Set tasselli di fissaggio (8 pz)
<b>A-93033</b>	Extension pad kit - Kit prolunghe tamponi 60mm - 160mm

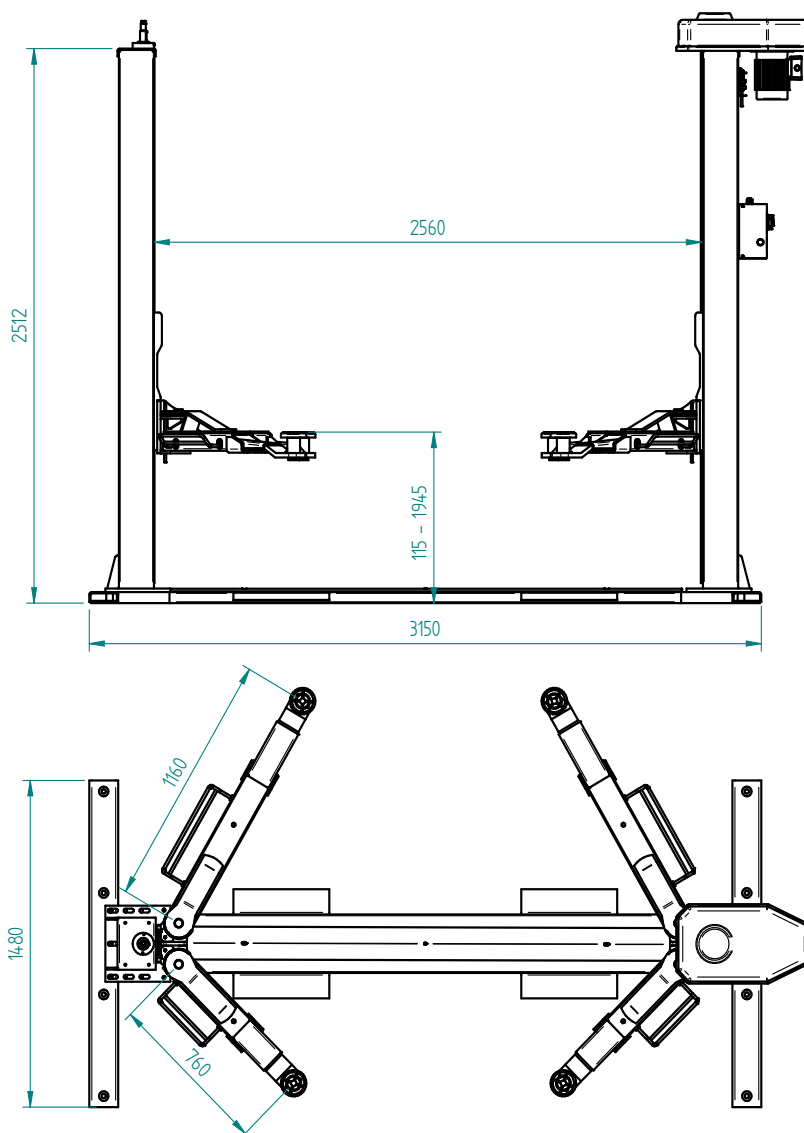

On request: 60mm / 160mm Extension kit  
 STANDARD COLOURS: BLU RAL 5002 - GREY RAL 7016

A richiesta kit prolunghe : 60mm / 160mm  
 COLORI STANDARD: BLU RAL 5002 - GRIGIO RAL 7016



# GT - EL 40



Two post electro-mechanical lift - with air or floor connection - mechanical drive - 2 independent electronically synchronized engines - double safety nut and breakage microswitch - asymmetrical columns - motor power 2 x 3,6 kw-400V/3PH 50Hz

Sollevatore elettromeccanico 2 colonne con connessione aerea o a pavimento - trasmissione meccanica - 2 motori indipendenti sincronizzati elettronicamente - chiocciola doppia di sicurezza e microinterruttore anti rottura - colonne asimmetriche - potenza motore 2 x 3,6 kw - 400V/3PH-50Hz

MODEL	CAPACITY	COLUMNS HIGHT	COLUMNS DISTANCE	LIFTING HIGHT	DESCRIPTION
<b>GT-EL 40</b>	4.0 T	2585 mm	2755	65 - 1925	2 post electro-mechanical lift - extension short arms (min 640/max 1200) - extension long arms ( min 775/ max 1550) - engine power 2 x 3.6kw - 400V/3PH-50Hz. CABLE CONNECTION IN THE FLOOR Sollevatore elettromeccanico a 2 colonne - bracci anteriori corti a 2 sfill (min 640/max 1200) - bracci posteriori lunghi a 1 sfilo (min 775/max 1550) - Potenza motore 2 x 3.6kw - 400V/3PH/50Hz. CONNESSIONE INCASSATA NEL PAVIMENTO
<b>GT-EL 40 C</b>	4.0 T	3800 mm (+1215 mm)	2755	65 - 1925	2 post electro-mechanical lift - extension short arms (min 640/max 1200) - extension long arms ( min775/max1550) - engine power 2 x 3.6kw - 400V/3PH. ELECTRICAL CABLE WITH AIR CONNECTION up to 3800mm Sollevatore elettromeccanico a 2 colonne - bracci anteriori corti a 2 sfill (min 640/max 1200) - bracci posteriori lunghi a 1 sfilo (min 775/max 1550)-Potenza motore 2x3.6kw-400V/3PH/50Hz. CONNESSIONE AEREA fino a 3800mm
<b>GT-EL 40 A</b>	4.0 T	4500 mm (+1915 mm)	2755	65 - 1925	2 post electro-mechanical lift - extension short arms (min 640/max 1200) - extension long arms ( min775/max1550) - engine power 2 x 3.6kw - 400V/3PH. ELECTRICAL CABLE WITH AIR CONNECTION up to 4500mm Sollevatore elettromeccanico a 2 colonne - bracci anteriori corti a 2 sfill (min 640/max 1200) - bracci posteriori lunghi a 1 sfilo (min 775/max 1550) - Potenza motore 2x3.6kw-400V/3PH/50Hz. CONNESSIONE AEREA fino a 4500mm

**4.000 Kg**



**GALTA**

On request: 60mm / 160mm Extension kit  
STANDARD COLOURS: BLU RAL 5002 - GREY RAL 7016

A richiesta kit prolunghie : 60mm / 160mm  
COLORI STANDARD: BLU RAL 5002 - GRIGIO RAL 7016



# OPTIONAL

CODE	DESCRIPTION
<b>A-93007</b>	Kit for vehicle 4WD - Kit 4 tamponi speciali per veicoli 4WD
<b>A-93008</b>	Adaptator for Mercedes / Iveco=105 - Adattatori per Mercedes / Iveco
<b>A-93009</b>	Adaptator for Mercedes / Iveco=135 - Adattatori per Mercedes / Iveco
<b>A-93033</b>	Kit extension pad + brackets - Kit prolungha tampone + staffe



**ARMS EXTENSION**  
ESTENSIONE BRACCI



**ELECTRICAL CONTROL BOX**  
QUADRO ELETTRICO



**RUBBER PAD**  
TAPPONE IN GONNE



**ELECTRONIC CONTROL FOR ALIGNMENT**  
CONTROLLO ELETTRONICO  
DEI MOTORI AD OGNI GIRO DELLA  
PULEGGIA



**ARMS LOCK**  
BLOCCA BRACCI



**MERCEDES/IVECO ADAPTORS**  
ADATTATORI MERCEDES/IVECO







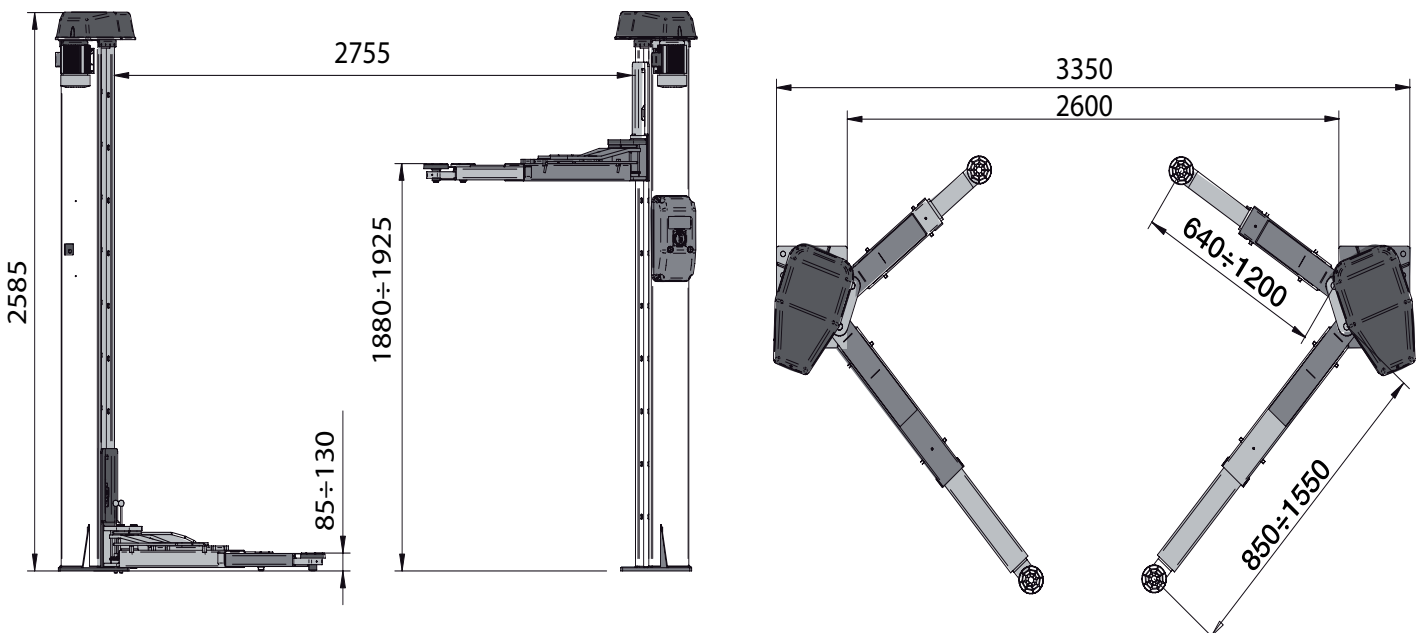
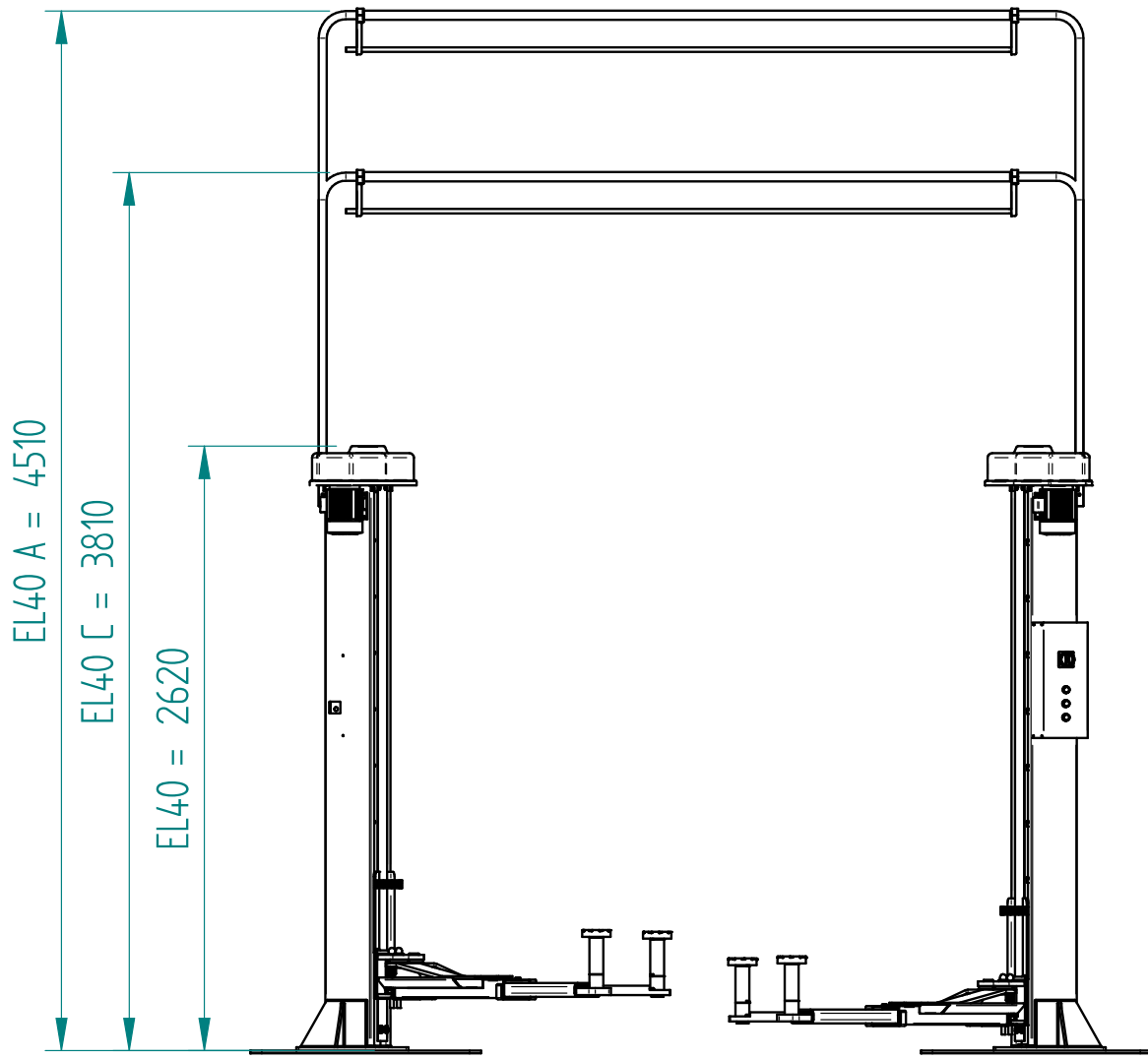

TWO POST LIFTS | PONTI DUE COLONNE

# GT - V 80



Two post lift with upper connection, hydraulic drive - 2 tracting cylinders directly connected to the carriages - mechanical safety lock with electromagnetic release - standard engine power 3 KW - 400 V/3 PH/50 Hz

Sollevatore elettroidraulico 2 colonne con connessione aerea, trasmissione idraulica - 2 cilindri in spinta connessi direttamente ai carrelli - sgancio sicure elettromagnetico - sicure meccaniche - colonne simmetriche - potenza motore 3 KW - 400V/3PH/50Hz

MODEL	CAPACITY	COLUMNS HIGHT	COLUMNS DISTANCE	LIFTING HIGHT	DESCRIPTION
<b>GT-V 80</b>	8.0 T	3980 mm (base)	3200	95 - 2050	2 post electrohydraulic lift with supporting crossbeam - 2 stages arms (min 860/max 1700) - engine power 3 kw - 400V/3PH Sollevatore elettroidraulico a 2 colonne con traversa portante - bracci a 2 sfill (min 860/max 1700) - Potenza motore 3 kw - 400V/3PH/50Hz
<b>GT-V 80 X</b>	8.0 T	4980 mm (+1000mm)	3200	95 - 2050	2 post electrohydraulic lift with supporting crossbeam - 2 stages arms (min 860/max 1700) - engine power 3 kw - 400V/3PH Column extension 1000mm Sollevatore elettroidraulico a 2 colonne con traversa portante - bracci a 2 sfill (min 860/max 1700) - Potenza motore 3 kw - 400V/3PH/50Hz. Prolungamento colonna 1000mm
<b>GT-V 80 XL</b>	8.0 T	5980 mm (+2000mm)	3200	95 - 2050	2 post electrohydraulic lift with supporting crossbeam - 2 stages arms (min 860/max 1700) - engine power 3kw - 400V/3PH. Column extension 1200 mm Sollevatore elettroidraulico a 2 colonne con traversa portante - bracci a 2 sfill (min 860/max 1700) - Potenza motore 3 kw - 400V/3PH/50Hz. Prolungamento colonna 1200 mm



**8.000 Kg**



# GALTA

STANDARD: 60mm / 160mm Extension kit  
STANDARD COLOURS: BLU RAL 5002 - GREY RAL 7016

Standard kit prolunghe 60mm / 160mm  
COLORI STANDARD: BLU RAL 5002 - GRIGIO RAL 7016

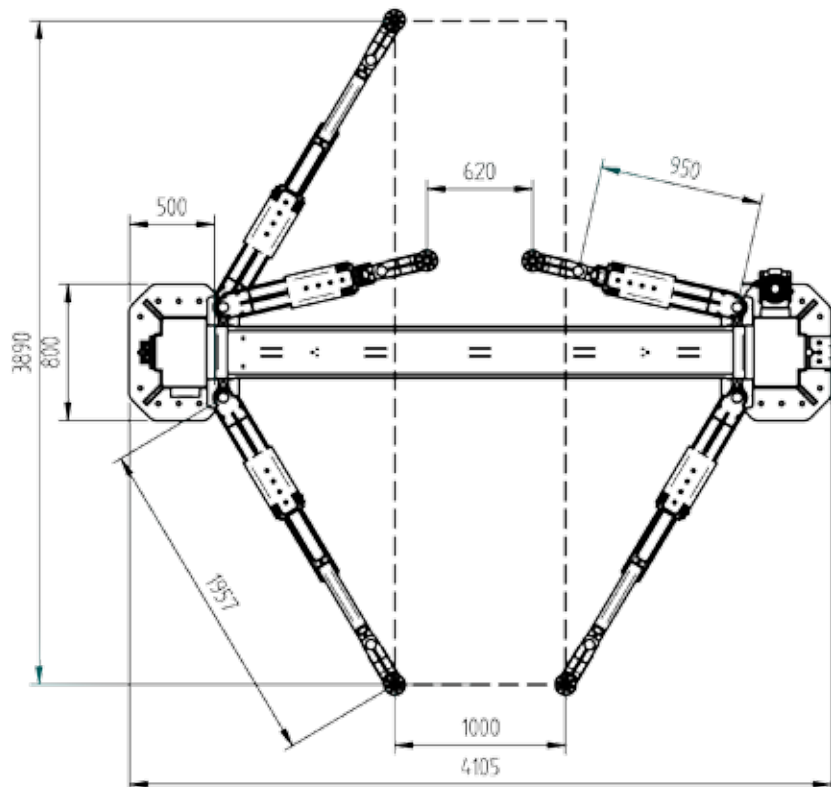
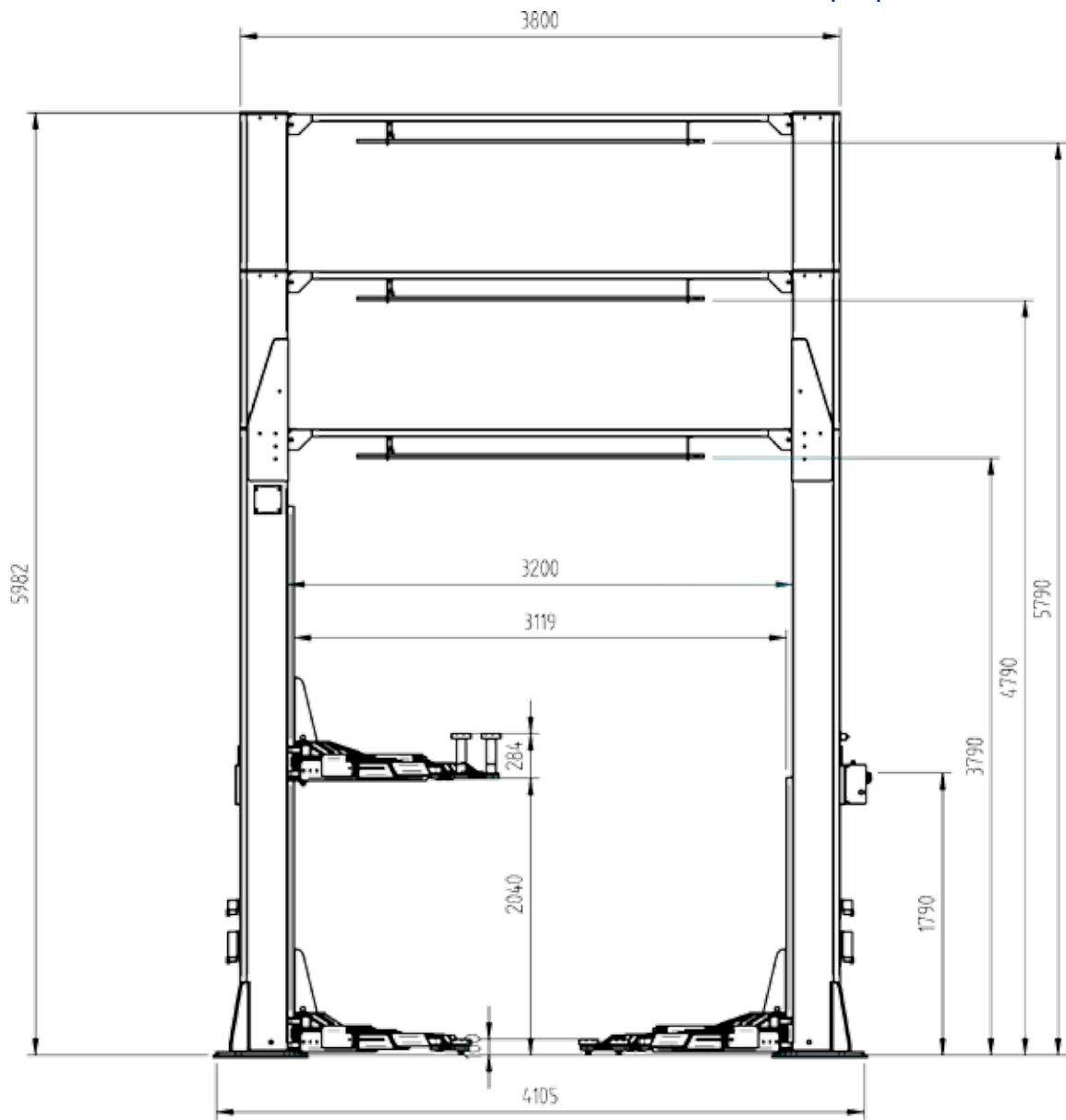



# GT - V 80



MERCEDES/IVECO ADAPTORS  
ADATTATORI MERCEDES/IVECO



EXTENSION ARMS  
ESTENSIONE BRACCI



MECHANICAL SAFETY LOCK  
SICURA MEC. IN ACCIAIO SPECIALE

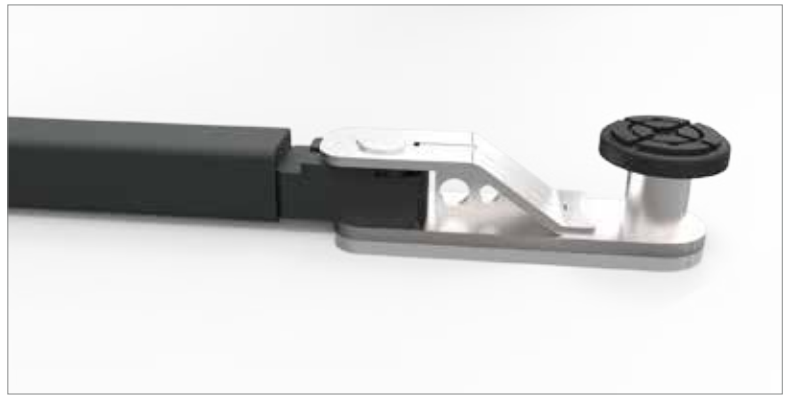

ESTENSIONE REGOLABILE DI 180°  
EXTENSION ADJUSTABLE 180°

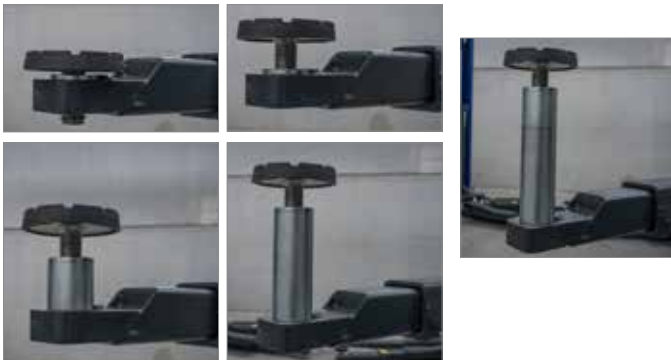

EXTENSION COLOUMN  
ESTENSIONI COLONNA



CONTROL BOX  
QUADRO ELETTRICO



**1** ANTI COLLISION BAR  
BARRA ANTI COLLISIONE

**4** EXTENSIONS PAD  
PROLUNGHE TAMPONE

**2** EXTENSIONS COLUMNS  
PROLUNGHE COLONNE

**5** ELECTROMAGNETIC SAFETY RELEASE  
SGANCIO SICURE ELETTROMAGNETICO

**3** SYMMETRICAL COLUMNS  
COLONNE SIMMETRICHE

**6** DOUBLE EXTENSIONS ARMS  
BRACCI A DOPPIO SFILÒ

**8.000 Kg**

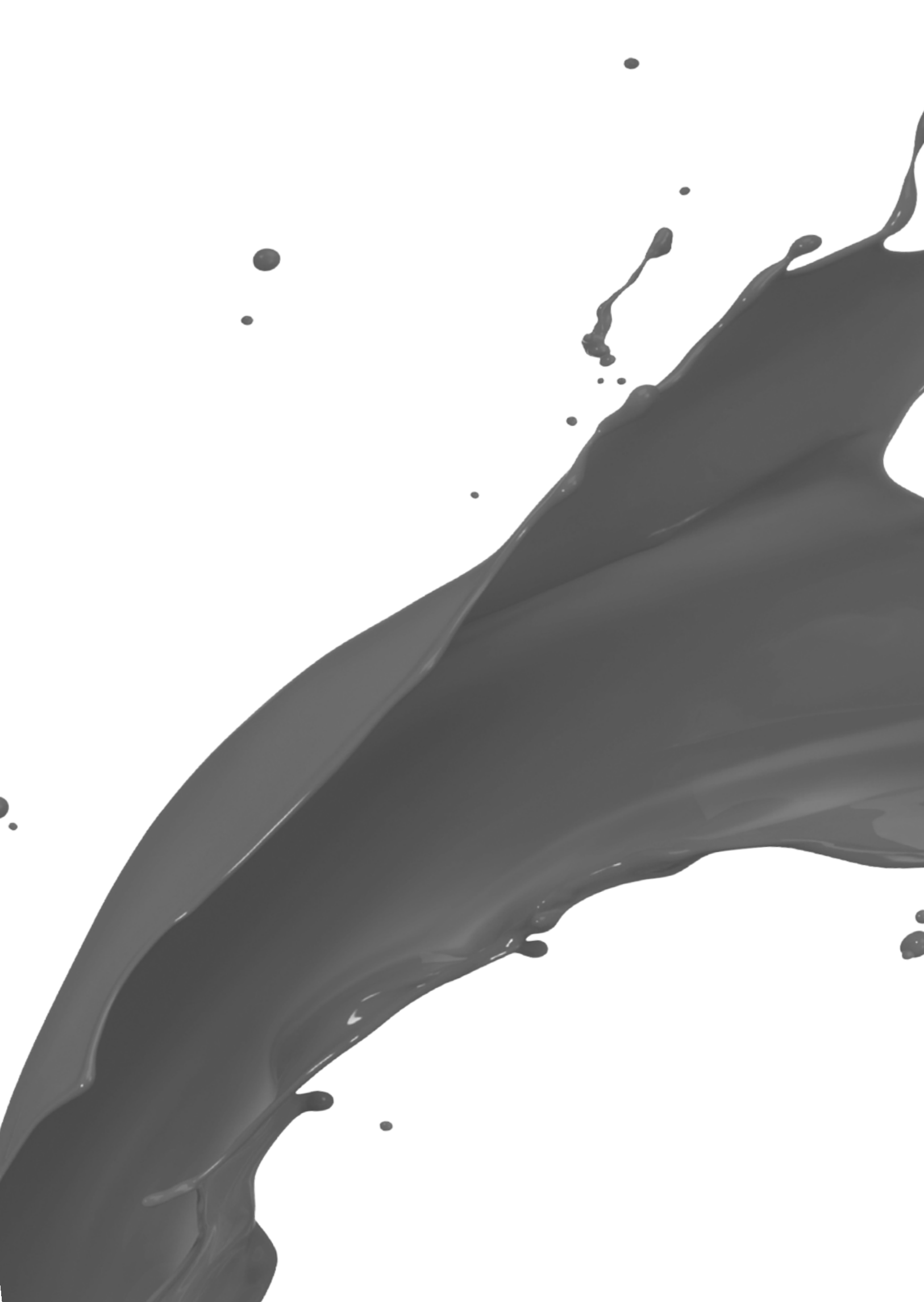



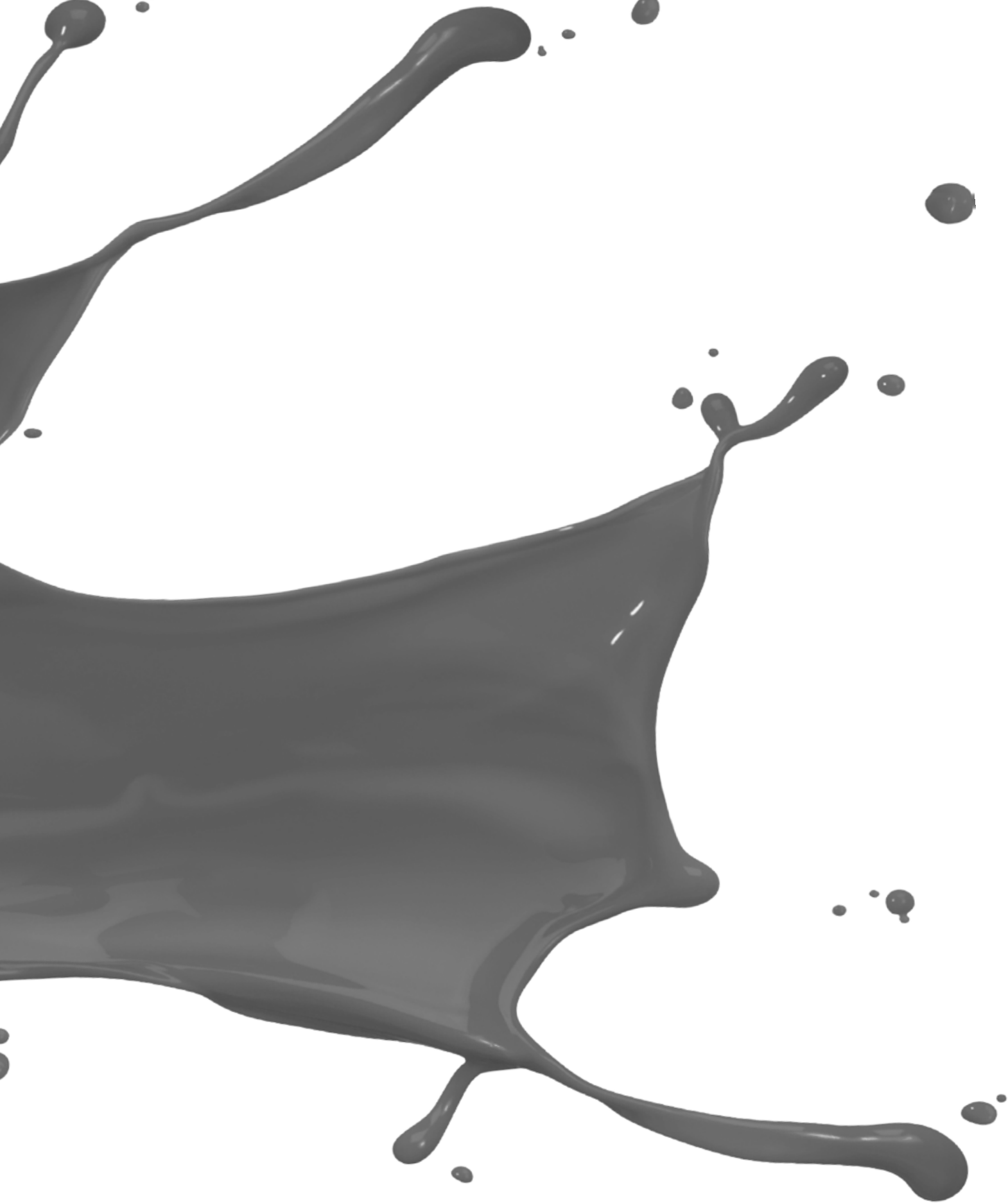

**grey line**

# GT - BS 4.0 - 5.5



Electrohydraulic scissor lift with double manual alignment and anti-knock valve - Lifting height: 330 - 2160 mm - pneumatic release with safety lock - version 5.5T with double cylinder - standard engine power 2,2/3,0 KW - 400V/3PH/50Hz - Required pneumatic connection for safe release 6/8 bar STANDARD VERSION RECESSED (floor version on request with addition of up and down ramps)

Sollevatore a forbice elettro-idraulico con doppio allineamento e valvola paracadute - altezza di sollevamento 330 - 2160 mm - sicure a sgancio pneumatico - versione 5.5T con doppio cilindro - potenza motore 2.2/3.0KW - 400V/3PH/50Hz. Richiesta connessione pneumatica per lo sgancio delle sicure 6/8 bar VERSIONE A INCASSO STANDARD (versione a pavimento a richiesta con aggiunta di rampe salita e fermo ruota)

MODEL	LIFT CAPACITY	PLATFORM (mm)	LT CAPACITY	DESCRIPTION
GT-BS 4.0 A	4.0 T	4500 x 610	4.0 T	Lift Table with lifting height of 450mm - lifting capacity 4000Kg - front recess length 980mm - sliding plates 1684mm - safety lock with pneumatic release - engine power 2.2Kw - 400v/50Hz/3ph Lift table con altezza sollevamento 450mm - incavo anteriore lunghezza 980mm - piani oscillanti 1684mm - sicura con sgancio pneumatico - potenza motore 2.2Kw - 400v/50Hz/3ph
GT-BS 5.5 A	5.5 T	5030 x 620	5.5 T	Lift Table with lifting height of 450mm - front recess length 1170mm - sliding plates 1784mm - safety lock with pneumatic release - double cylinder - engine power 3.0Kw - 400v/50Hz/3ph Lift table con altezza sollevamento 450mm - incavo anteriore lunghezza 1170mm - piani oscillanti 1784mm - sicura con sgancio pneumatico - doppio cilindro - potenza motore 3.0Kw - 400v/50Hz/3ph



ROLLING JACK RAILS STANDARD  
CORSIE SCORRIMENTO ROLLING JACK STANDARD



# OPTIONAL

CODE	DESCRIPTION	
<b>B-93013</b>	LED lamps 24 Volt - Set 4 lampade 24 Volt LED	
<b>B-93014</b>	Expansion bolts set (12 pz) - Set tasselli di fissaggio (12pz)	
<b>B-93016</b>	Approaching ramps for on ground installation - Set rampe salita per versione a pavimento	
<b>B-93025</b>	Turning plates set with covers - Set piatti rotanti con copertura	
<b>B-93021</b>	Wires-pipes extension set L= +1 m - Set estensioni tubi-cavi L= +1 m	
<b>B-93022</b>	Wires-pipes extension set L= +2 m - Set estensioni tubi-cavi L= +2 m	
<b>B-93023</b>	Wires-pipes extension set L= +3 m - Set estensioni tubi-cavi L= +3 m	
<b>A-93019</b>	Set rubber pad H= 60 mm (4 pz) - Set tamponi H= 60 mm (4 pz)	
<b>A-93020</b>	Set rubber pad H= 120 mm (4 pz) - Set tamponi H= 120 mm (4 pz)	
<b>B-93039</b>	Rubber ramps H=30mm - Rampe in gomma H=30mm	ONLY FOR FLOOR VERSION / SOLO PER VERSIONE A PAVIMENTO
<b>B-93040</b>	Rubber ramps H=50mm - Rampe in gomma H=50mm	ONLY FOR FLOOR VERSION / SOLO PER VERSIONE A PAVIMENTO



STANDARD LIFT TABLE  
TORRETTA STANDARD

All models are provided with 4 rubber.

ALL OUR PRODUCT ARE SUPPLIED WITH SANDBLASTING. STANDARD COLOURS: GREY RAL 7016 - GREY RAL 7040

Tutti i modelli vengono forniti con 4 tamponi in gomma.

SU TUTTI I PONTI VIENE APPLICATO IL TRATTAMENTO DI SABBIAIATURA. COLORI STANDARD: GRIGIO RAL 7016 - GRIGIO RAL 7040

# GT - BS - 4.0

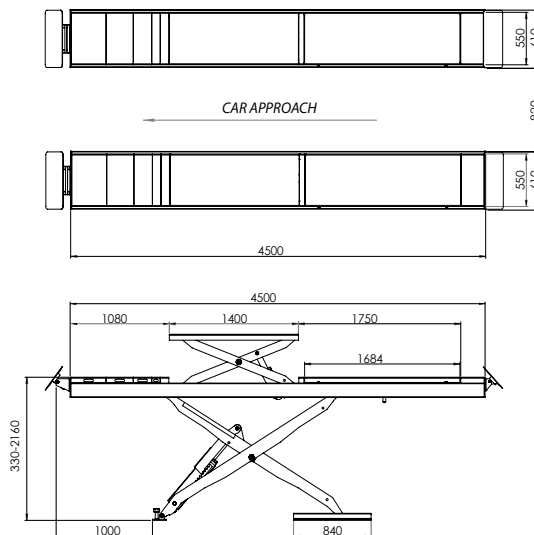
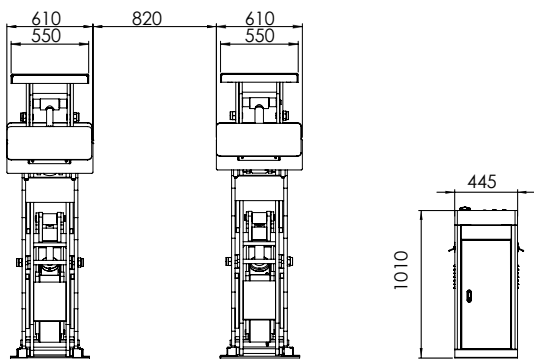

# GT - BS 5.5

**DOUBLE CYLINDER - DOPPIO CILINDRO**

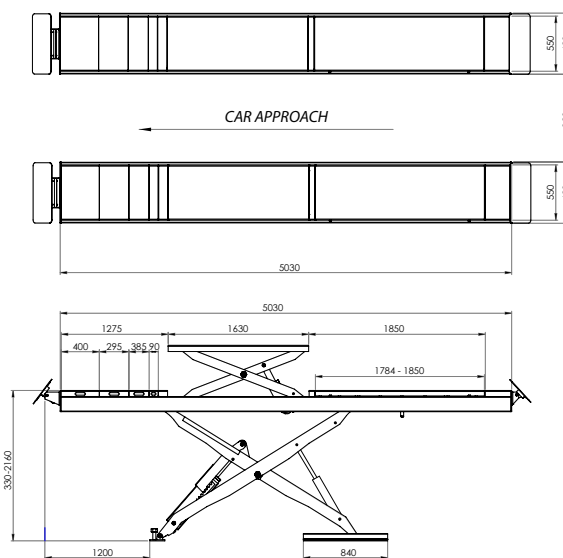
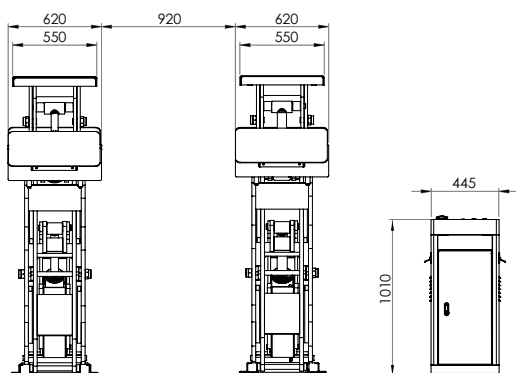

**STANDARD** LIFT TABLE WITH 2 EXTENSION  
LIFT TABLE CON 2 ESTENSIONE



# GT - BS

4.000 Kg

5.500 Kg

**1** CONTROL UNIT WITH TRIPLE OPENING  
CENTRALINA CON TRIPLA APERTURA

**2** STANDARD LIFT TABLE  
LIFT TABLE

**3** SLADING PLATES  
PIANI OSCILLANTI

**4** CYLINDER WITH MECHANICAL SAFETY RELEASE  
SICURA MECCANICA SUI CILINDRI

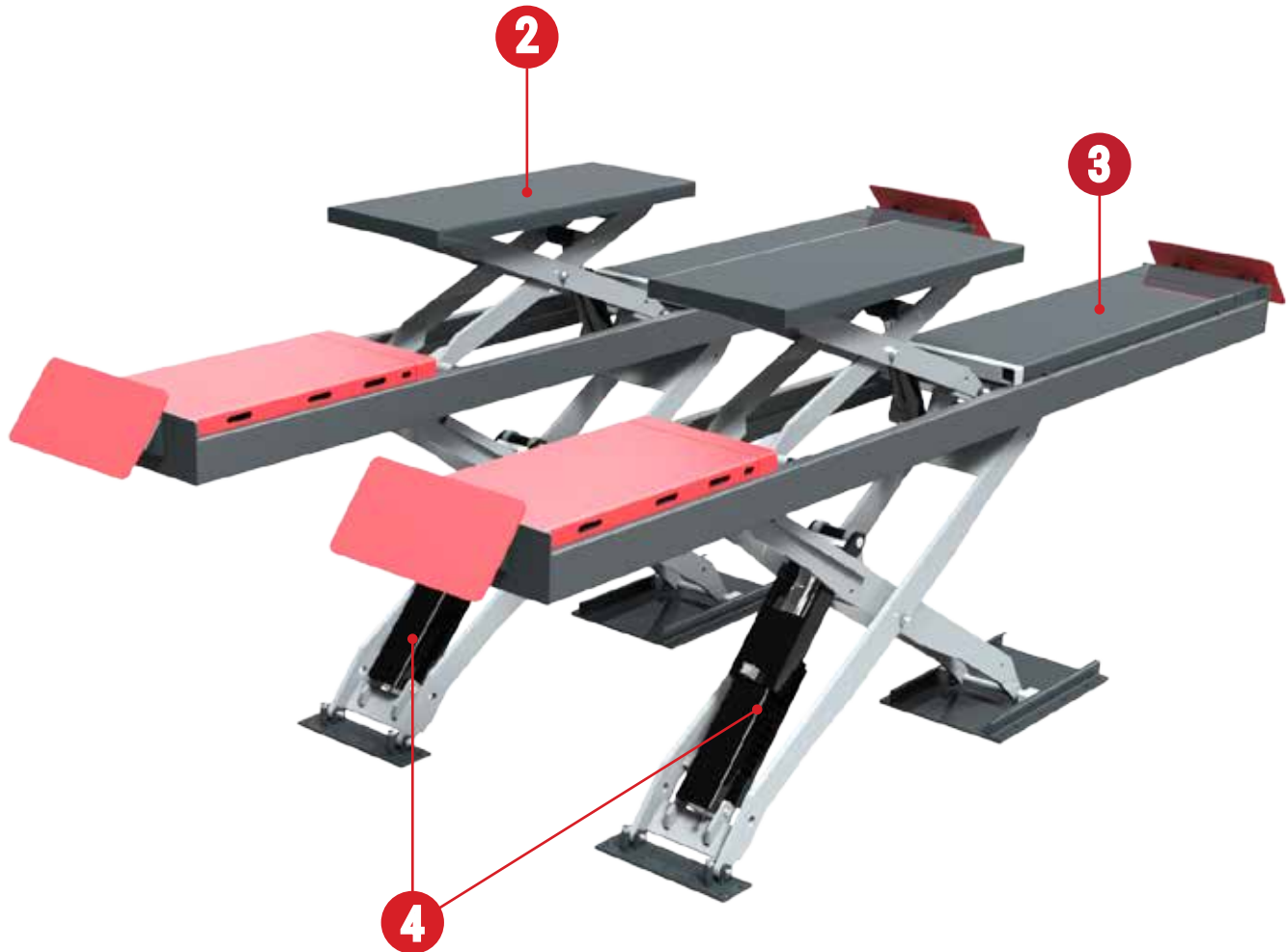

**1**



RUBBER RAMPS H=30/50mm  
RAMPA IN GOMMA H=30/50mm

OPTIONAL

# GT - BSL 4.0

# GT - BSL 5.5 **DOUBLE CYLINDER - DOPPIO CILINDRO**



Electrohydraulic scissor lift with double alignment - pneumatic release - safety lock - antiknock valve - Lifting Height 330-2160mm - standard engine power 2,2/3,0 KW/400V/3PH/50Hz. Required pneumatic connection for safe release 6/8 bar. **STANDARD VERSION RECESSED** (floor version on request with addition of up and down ramps)

Sollevatore a forbice elettro-idraulico con doppio allineamento - sgancio sicura pneumatico - valvola paracadute e con altezza di sollevamento di 330-2160mm - potenza motore 2,2/3,0KW/400V/3PH/50Hz. Richiesta connessione pneumatica per lo sgancio delle sicure 6/ bar. **VERSIONE A INCASSO STANDARD** (versione a pavimento a richiesta con aggiunta di rampe salita e fermo ruota)

MODEL	LIFT CAPACITY	PLATFORM (mm)	DESCRIPTION
<b>GT-BSL 4.0 A</b>	4.0 T	4500 x 654	Front recess length 990mm - sliding plates 1684mm - safety lock with pneumatic release - engine power 2.2Kw - 400v/50Hz/3ph Incavo anteriore lunghezza 990mm - piani oscillanti 1684mm - sicura con sgancio pneumatico - 2.2Kw - 400v/50Hz/3ph
<b>GT-BSL 5.5 A</b>	5.5 T	5030 x 667	Front recess length 1180mm - sliding plates 1784mm - safety lock with pneumatic release - <b>double cylinder</b> - engine power 3.0Kw - 400v/50Hz/3ph Incavo anteriore lunghezza 1180mm - piani oscillanti 1784mm - sicura con sgancio pneumatico - <b>doppio cilindro</b> - 3,0Kw - 400v/50Hz/3ph



ROLLING JACK RAILS STANDARD  
CORSIE SCORRIMENTO ROLLING JACK STANDARD

**4.000 Kg**

**5.500 Kg**

On request all platforms can be provided with sliding plates, turning plates and rolling jack. All our product are supplied with sandblasting. **STANDARD COLOURS: GREY RAL 7016 - GREY RAL 7040**

A richiesta tutte le pedane possono ospitare piani oscillanti, piatti rotanti e rolling jack. Su tutti i ponti viene applicato il trattamento di sabbiatura. **COLORI STANDARD: GRIGIO RAL 7016 - GRIGIO RAL 7040**

# OPTIONAL

CODE	DESCRIPTION	
<b>B-93013</b>	LED lamps 24 Volt - Set 4 lampade 24 Volt LED	
<b>B-93014</b>	Expansion bolts set (12 pz) - Set tasselli di fissaggio (12pz)	
<b>B-93016</b>	Approaching ramps for on ground installation - Set rampe salita per versione a pavimento	
<b>B-93025</b>	Turning plates set with covers - Set piatti rotanti con copertura	
<b>B-93021</b>	Wires-pipes extension set L= +1 m - Set estensioni tubi-cavi L= +1 m	
<b>B-93022</b>	Wires-pipes extension set L= +2 m - Set estensioni tubi-cavi L= +2 m	
<b>B-93023</b>	Wires-pipes extension set L= +3 m - Set estensioni tubi-cavi L= +3 m	
<b>A-93019</b>	Set rubber pad H= 60 mm (4 pz) - Set tamponi H= 60 mm (4 pz)	
<b>A-93020</b>	Set rubber pad H= 120 mm (4 pz) - Set tamponi H= 120 mm (4 pz)	
<b>A-93039</b>	Rubber ramps H=30mm - Rampe in gomma H=30mm	ONLY FOR FLOOR VERSION / SOLO PER VERSIONE A PAVIMENTO
<b>A-93040</b>	Rubber ramps H=50mm - Rampe in gomma H=50mm	ONLY FOR FLOOR VERSION / SOLO PER VERSIONE A PAVIMENTO

## GT - BSL 4.0

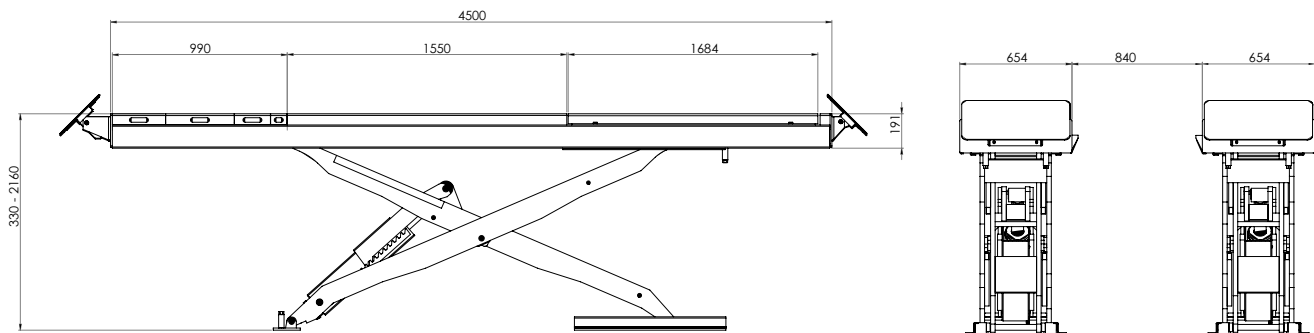

## GT - BSL 5.5

**DOUBLE CYLINDER - DOPPIO CILINDRO**

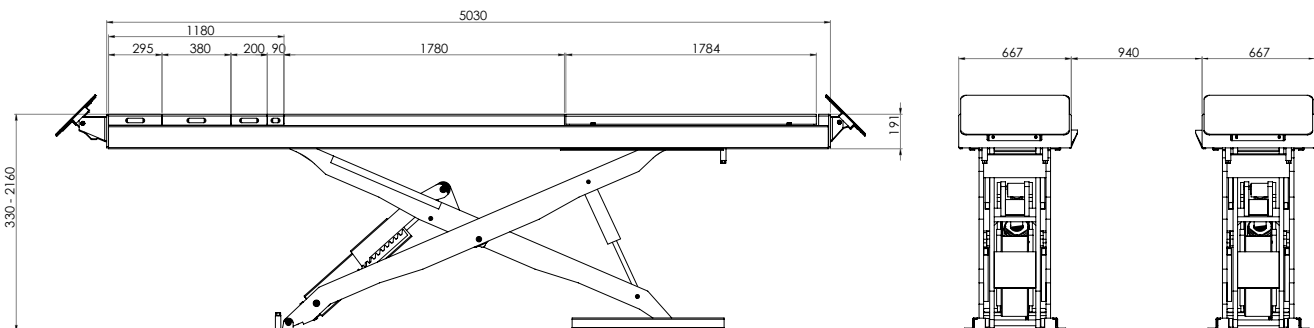

# GT - BSLP 3.5 - 5.5



Low profile electrohydraulic scissor lift - antiknock valve - lifting height: 220-1880mm - pneumatic release with safety lock - 3 cylinders per platform - Standard engine power 3,0 KW/400V/3PH/50Hz. Required pneumatic connection for safe release 6/8 bar. (VERSION ON FLOOR)

Sollevatore a forbice elettro-idraulico per assetto a basso profilo - valvola paracadute - altezza di sollevamento 220 - 1880mm - sicure a sgancio pneumatico - 3 cilindri per pedana - potenza motore 3.0KW - 400V/3PH/50Hz. Richiesta connessione pneumatica per lo sgancio delle sicure 6/8 bar. (VERSIONE A PAVIMENTO)

MODEL	LIFT CAPACITY	PLATFORM (mm)	LT CAPACITY	DESCRIPTION
GT-BSLP 3.5 A	3.5 T	4200 x 680	3.5 T	Lift Table with lifting height of 450mm - lifting capacity 3500Kg - front recess length 970mm (4200X680) - sliding plates 1320mm (4200X680) - movable rear cover - safety lock with pneumatic release - 2 front cylinders - 1 rear cylinder - lift table with mechanical safety lock - engine power 3.0Kw - 400v/50Hz/3ph Lift table con altezza sollevamento 450mm - incavo anteriore lunghezza 970mm (4200X680) - piani oscillanti 1320mm (4200 x 680) - sicura con sgancio pneumatico - 2 cilindri anteriori - 1 cilindro posteriore sicura meccanica della torretta 3.0Kw - 400v/50Hz/3ph
GT-BSLP 5.5 A	5.5 T	5030 x 704	5.5 T	Lift Table with lifting height of 450mm - lifting capacity 5500Kg - front recess length 1270 (5030x704) - sliding plates 1850mm (5030X704) - movable rear cover - safety lock with pneumatic release - 2 front cylinders - 1 rear cylinder - Lift Table with mechanical safety lock - engine power 3.0Kw - 400v/50Hz/3ph Lift table con altezza sollevamento 450mm portata 5500kg -incavo anteriore lunghezza 1270 (5030 X 704) - piani oscillanti - 1850mm (5030 x 704) - sicura con sgancio pneumatico- 2 cilindri anteriori - 1 cilindro posteriore sicura meccanica della torretta 3.0Kw - 400v/50Hz/3ph



ROLLING JACK RAILS STANDARD - CORSIE ROLLING JACK DTANDARD





# OPTIONAL

CODE	DESCRIPTION	
<b>B-93013</b>	LED lamps 24 Volt - Set 4 lampade 24 Volt LED	
<b>B-93014</b>	Expansion bolts set (12 pz) - Set tasselli di fissaggio (12pz)	
<b>B-93025</b>	Turning plates set with covers - Set piatti rotanti con copertura	
<b>B-93021</b>	Wires-pipes extension set L= +1 m - Set estensioni tubi-cavi L= +1 m	
<b>B-93022</b>	Wires-pipes extension set L= +2 m - Set estensioni tubi-cavi L= +2 m	
<b>B-93023</b>	Wires-pipes extension set L= +3 m - Set estensioni tubi-cavi L= +3 m	
<b>A-93019</b>	Set rubber pad H= 60 mm (4 pz) - Set tamponi H= 60 mm (4 pz)	
<b>A-93020</b>	Set rubber pad H= 120 mm (4 pz) - Set tamponi H= 120 mm (4 pz)	
<b>A-93039</b>	Rubber ramps H=30mm - Rampe in gomma H=30mm	ONLY FOR FLOOR VERSION / SOLO PER VERSIONE A PAVIMENTO
<b>A-93040</b>	Rubber ramps H=50mm - Rampe in gomma H=50mm	ONLY FOR FLOOR VERSION / SOLO PER VERSIONE A PAVIMENTO



RUBBER RAMPS H=30/50mm  
RAMPA IN GOMMA H=30/50mm

OPTIONAL

## STANDARD LIFT TABLE WITH 2 EXTENSION LIFT TABLE CON 2 ESTENSIONE



3 CYLINDER PER PLATFORM  
TRE CILINDRI PER PEDANA

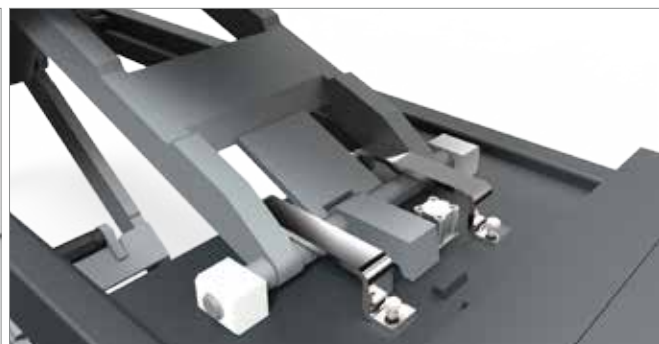

MECHANICAL SAFETY LOCK  
SICURA MECCANICA

All models are provided with 4 rubber On request all platforms can be provided with sliding plates - turning plates - HPD - lift table with 1 extension - lift table with 2 extensions. All our product are supplied with sandblasting.

STANDARD COLOURS: GREY RAL 7016 - GREY RAL 7040

Tutti i modelli vengono forniti con 4 tamponi in gomma. A richiesta tutte le pedane possono ospitare piani oscillanti, piatti rotanti - torretta con 1 estensione - torretta con 2 estensioni. Su tutti i ponti viene applicato il trattamento di sabbiatura.

COLORI STANDARD: GRIGIO RAL 7016 - GRIGIO RAL 7040

# GT - BSLP 3.5 - 5.5

3.500 Kg

5.500 Kg



LIFT TABLE WITH 2 EXTENSION  
LIFT TABLE CON 2 ESTENSIONE



ROLLING JACK 2T / 3 T  
ROLLING JACK 2T / 3T

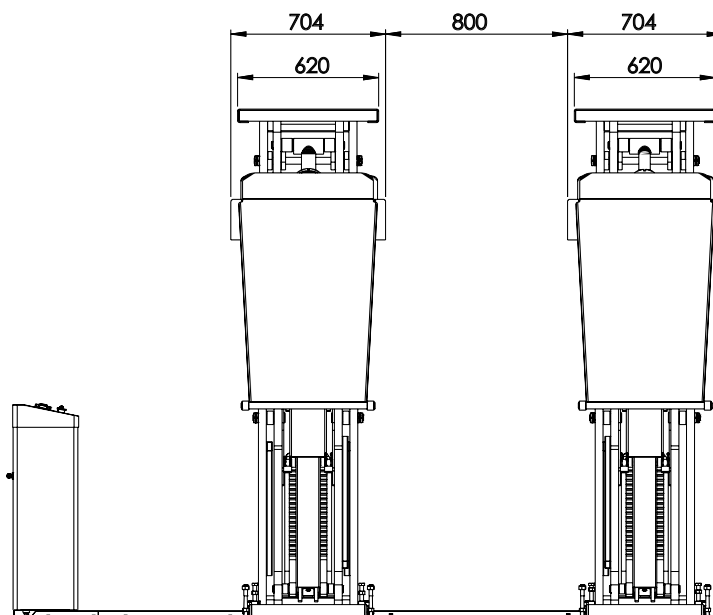
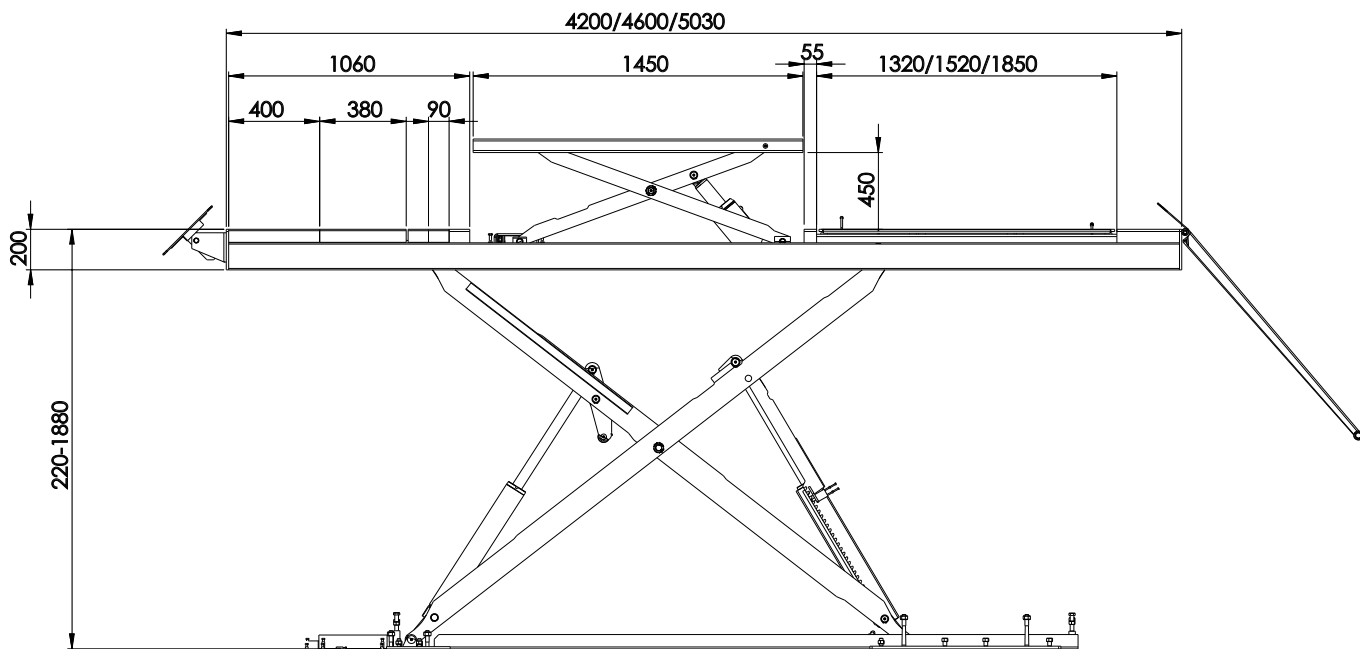

# GT - BSLP

- 1** MOBILE COVERS  
COPERTURE MOBILI
- 2** STANDARD LIFT TABLE  
LIFT TABLE
- 3** APPROACHING RAMPS  
RAMPE SALITA
- 4** SLADING PLATES  
PIANI OSCILLANTI
- 5** ASSISTANT CYLINDER WITH MECHANICAL SAFETY LOCK  
CILINDRO DI ASSISTENZA CON SICURA MECCANICA
- 6** DOUBLE CYLINDER MASTER/SLAVE  
DOPPIO CILINDRO MASTER/SLAVE
- 7** LIFT TABLE WITH MECHANICAL SAFETY LOCK WITH PNEUMATIC RELEASE  
LIFT TABLE CON SICURA MECCANICA A SGANCIO PNEUMATICO

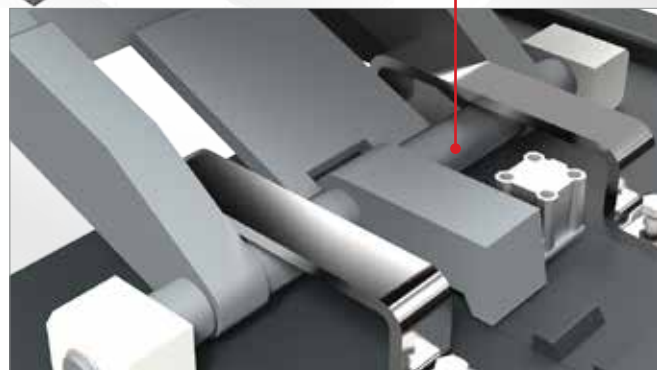

# GT - BSULP 4.0 - 5.5

**4.000 Kg** **5.500 Kg**

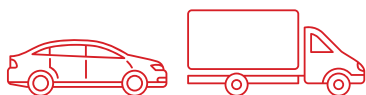

Ultra low profile electrohydraulic scissor lift (built-in recess) with double alignment and anti-knock valve - Lifting Height 200-1860mm - safety lock with pneumatic release - double cylinder - standard engine power 2.2/3.0 KW - 400V/3PH/50 Hz. Required pneumatic connection for safe release 6/8 bar. (VERSION ON FLOOR)

Sollevatore a forbice elettro-idraulico ribassato (incavi incassati) con doppio allineamento e valvola paracadute - altezza di sollevamento 200 - 1860mm - sicure a sgancio pneumatico - doppio cilindro - potenza motore 2.2/3.0KW - 400V/3PH. Richiede connessione pneumatica per lo sgancio delle sicure 6/8 bar (VERSIONE A PAVIMENTO)

MODEL	CAPACITY	PLATFORM (mm)	DESCRIPTION
GT-BSULP 4.0 A	4.0 T	4500 x 635	Platform with front recess length 900mm - sliding plates 1450mm - pneumatic release safety lock - 2.2Kw - 400v/50Hz/3ph Pedana ribassata con incavo anteriore lunghezza 900mm - piani oscillanti 1450mm - sicura con sgancio pneumatico - piano oscillante - 2.2Kw - 400v/50Hz/3ph
GT-BSULP 5.5 A	5.5 T	5030 x 635	Platform with front recess length 1100mm - sliding plates 1900 mm - safety lock with pneumatic release - double cylinder - engine power 3.0Kw - 400v/50Hz/3ph Pedana ribassata con incavo anteriore lunghezza 1100mm - piani oscillanti 1900mm - sicura con sgancio pneumatico - piano oscillante - potenza motore 3.0Kw - 400v/50Hz/3ph

STANDARD: ROLLING JACK RAILS - STANDARD: CORSIE ROLLING JACK



RUBBER RAMPS H=30mm  
RAMPA IN GOMMA H=30mm  
OPTIONAL

RUBBER RAMPS H=50mm  
RAMPA IN GOMMA H=50mm  
OPTIONAL





# OPTIONAL

CODE	DESCRIPTION	
<b>B-93013</b>	LED lamps 24 Volt - Set 4 lampade 24 Volt LED	
<b>B-93014</b>	Expansion bolts set (12 pz) - Set tasselli di fissaggio (12pz)	
<b>B-93025</b>	Turning plates set with covers - Set piatti rotanti con copertura	
<b>B-93021</b>	Wires-pipes extension set L= +1 m - Set estensioni tubi-cavi L= +1 m	
<b>B-93022</b>	Wires-pipes extension set L= +2 m - Set estensioni tubi-cavi L= +2 m	
<b>B-93023</b>	Wires-pipes extension set L= +3 m - Set estensioni tubi-cavi L= +3 m	
<b>A-93019</b>	Set rubber pad H= 60 mm (4 pz) - Set tamponi H= 60 mm (4 pz)	
<b>A-93020</b>	Set rubber pad H= 120 mm (4 pz) - Set tamponi H= 120 mm (4 pz)	
<b>A-93039</b>	Rubber ramps H=30mm - Rampe in gomma H=30mm	ONLY FOR FLOOR VERSION / SOLO PER VERSIONE A PAVIMENTO
<b>A-93040</b>	Rubber ramps H=50mm - Rampe in gomma H=50mm	ONLY FOR FLOOR VERSION / SOLO PER VERSIONE A PAVIMENTO

## ROLLING JACK RAILS STANDARD - CORSIE ROLLING JACK STANDARD

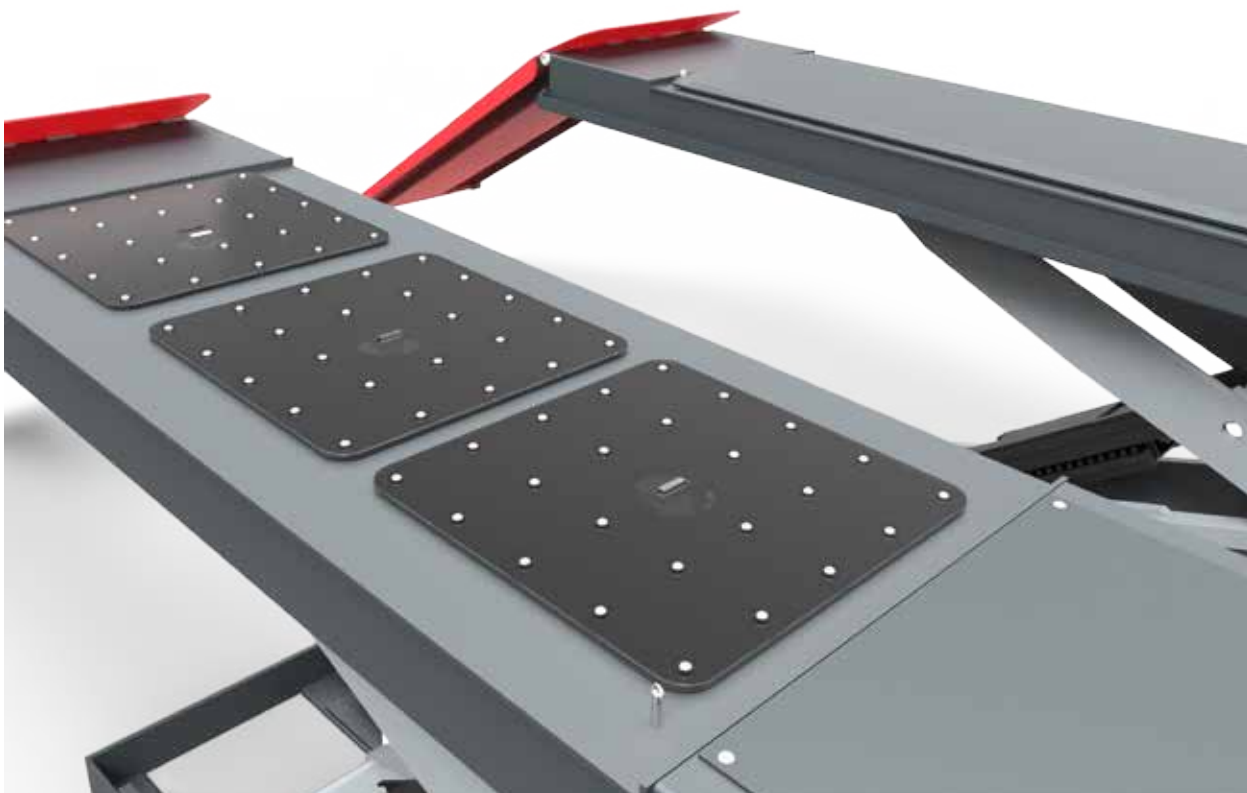

SLADING PLATES  
PIANI OSCILLANTI

On request all platforms can be provided with sliding plates, turning plates and rolling jack.  
All our product are supplied with sandblasting. STANDARD COLOURS: GREY RAL 7016 - GREY RAL 7040

A richiesta tutte le pedane possono ospitare piani oscillanti, piatti rotanti e rolling jack.  
Su tutti i ponti viene applicato il trattamento di sabbiatura..COLORI STANDARD: GRIGIO RAL 7016 - GRIGIO RAL 7040

# GT - BSULP

4.000 Kg

5.500 Kg

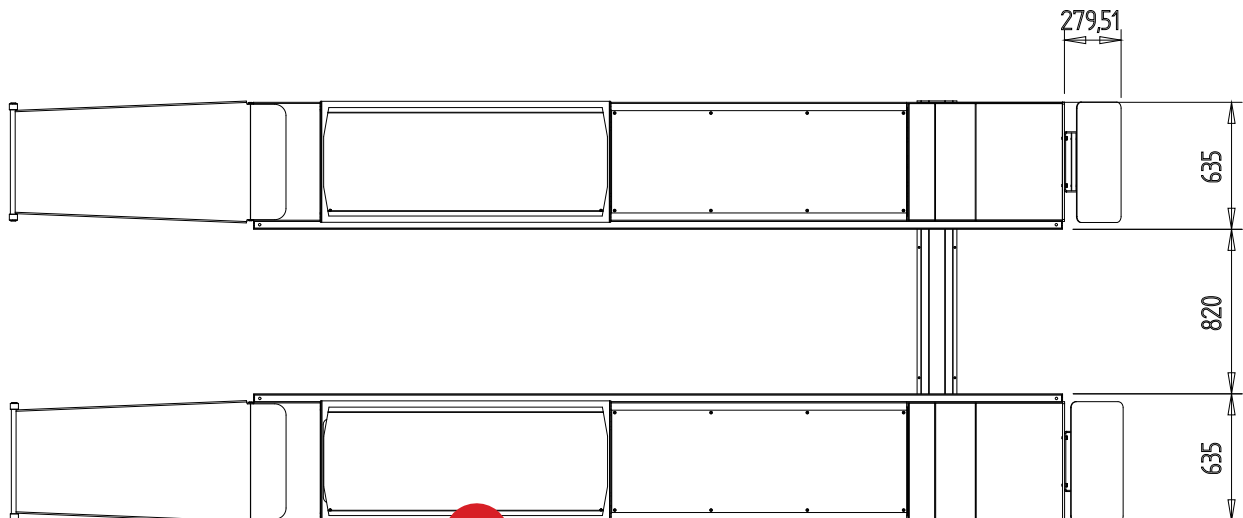
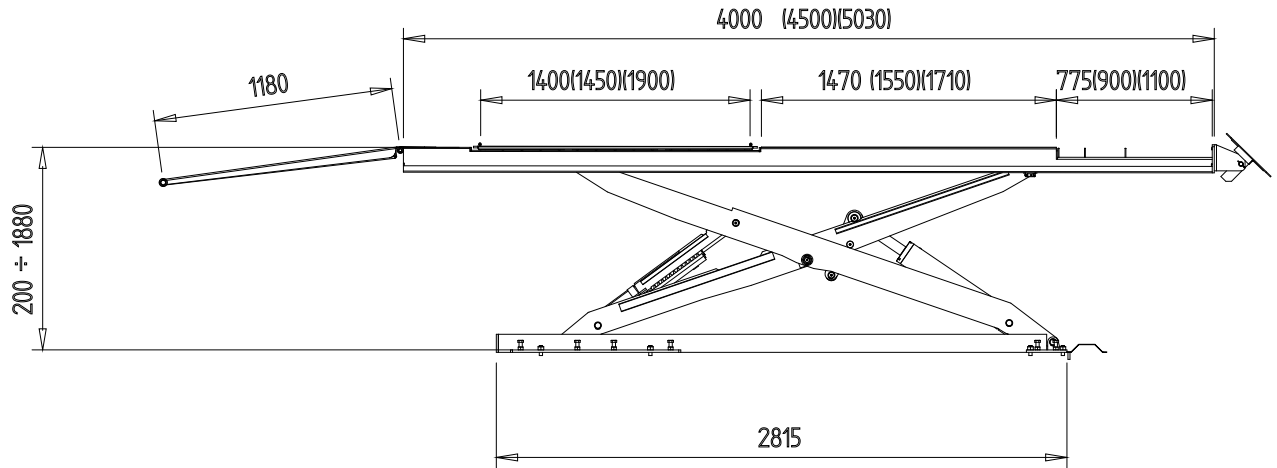

# GT - BSULP

- 1** MOBILE COVERS  
COPERTURE MOBILI
- 2** APPROACHING RAMPS  
RAMPE SALITA
- 3** SLADING PLATES  
PIANI OSCILLANTI
- 4** FRONT CYLINDER  
CILINDRO ANTERIORE
- 5** REAR CYLINDER WITH MECHANICAL SAFETY LOCK  
CILINDRO POSTERIORE CON SICURA MECCANICA
- 6** CONTROL UNIT WITH TRIPLE OPENING  
CENTRALINA CON TRIPLA APERTURA

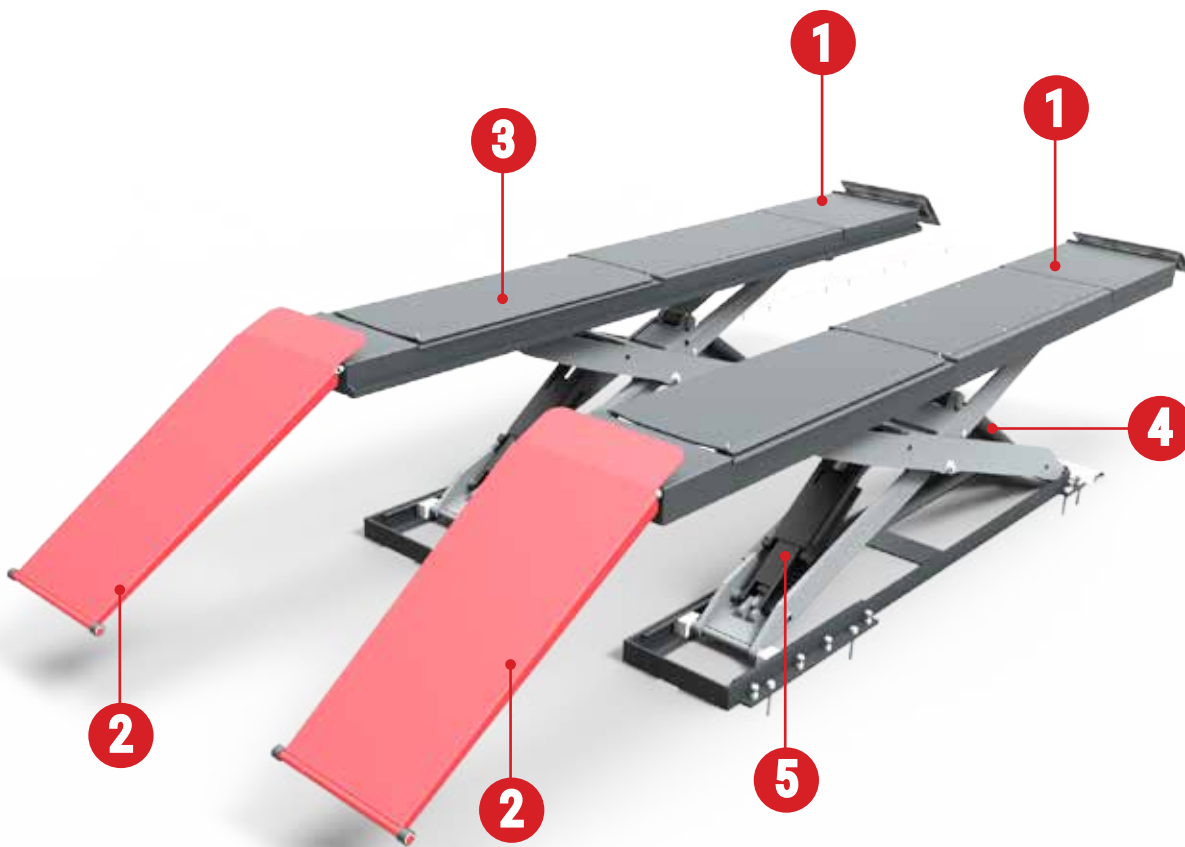

# GT-DS 3.0 - 3.5 - 4.0 MASTER

Available with mechanical or hydraulic safety device. Low profile electrohydraulic double scissor lift - anti knock valve - pneumatic released with safety lock - double cylinder - standard engine power 2,2 KW - 400 V/3 PH/50 Hz - on request: 2,2 KW - 220 V/1 PH/50 Hz. Required pneumatic connection for safe release 6/8 bar. (ON FLOOR OR RECESSED VERSION)

Disponibile con sicura meccanica o idraulica. Sollevatore elettro-idraulico a doppia forbice a basso profilo - doppio allineamento manuale e valvola paracadute - con sgancio sicura pneumatico - doppio cilindro - potenza motore 2.2KW - 400V/3PH/50HZ - A richiesta 2.2KW - 230V/1PH/50Hz. Richiesta connessione pneumatica per lo sgancio delle sicure 6/8 bar. (VERSIONE A INCASSO O A PAVIMENTO)

MODEL	LIFT CAPACITY	PLATFORM (mm)	PLATFORM WITH RAMPS	LIFTING HEIGHT	DESCRIPTION
<b>GT-DSH 3.0 MASTER</b> HYDRAULIC LOCK	3.0 T	1420 X 650	2000 X 650	100 X 1950	Low profile electrohydraulic double scissor lift - <b>hydraulic lock</b> - anti knock valve - Volumetric crossed hydraulic system - double cylinder - load bearing ramps - engine power 2.2kw - 400V/3PH Sollevatore elettro-idraulico a doppia forbice a basso profilo - valvola paracadute - impianto idraulico volumetrico incrociato - doppio cilindro - <b>sicura idraulica</b> - rampe portanti - potenza motore 2.2kw - 400V/3PH/50Hz
<b>GT-DSM 3.0 MASTER</b> MECHANICAL LOCK	3.0 T	1420 X 650	2000 X 650	100 X 1950	Low profile electrohydraulic double scissor lift - <b>mechanical lock</b> - anti knock valve - Volumetric crossed hydraulic system - double cylinder - load bearing ramps - engine power 2.2kw - 400V/3PH Sollevatore elettro-idraulico a doppia forbice a basso profilo - valvola paracadute - impianto idraulico volumetrico incrociato - doppio cilindro - rampe portanti - <b>sicura meccanica</b> - potenza motore 2.2kw - 400V/3PH/50Hz
<b>GT-DSH 3.5 MASTER</b> HYDRAULIC LOCK	3.5 T	1420 X 650	2000 X 650	105 - 1950	Low profile electrohydraulic double scissor lift - <b>hydraulic lock</b> - anti knock valve - Volumetric crossed hydraulic system - double cylinder - load bearing ramps - engine power 2.2kw - 400V/3PH Sollevatore elettro-idraulico a doppia forbice a basso profilo - valvola paracadute - impianto idraulico volumetrico incrociato - doppio cilindro - rampe portanti - <b>sicura idraulica</b> - potenza motore 2.2kw - 400V/3PH/50Hz
<b>GT-DSM 3.5 MASTER</b> MECHANICAL LOCK	3.5 T	1420 X 650	2000 X 650	105 - 1950	Low profile electrohydraulic double scissor lift - <b>mechanical lock</b> - anti knock valve - Volumetric crossed hydraulic system - double cylinder - load bearing ramps - engine power 2.2kw - 400V/3PH Sollevatore elettro-idraulico a doppia forbice a basso profilo - valvola paracadute - impianto idraulico volumetrico incrociato - doppio cilindro - rampe portanti - <b>sicura meccanica</b> - potenza motore 2.2kw - 400V/3PH/50Hz
<b>GT-DSH 4.0 MASTER</b> HYDRAULIC LOCK	4.0 T	1420 X 680	2000 X 680	115 - 1950	Low profile electrohydraulic double scissor lift - <b>hydraulic lock</b> - anti knock valve - Volumetric crossed hydraulic system - double cylinder - load bearing ramps - engine power 2.2kw - 400V/3PH Sollevatore elettro-idraulico a doppia forbice a basso profilo - valvola paracadute - impianto idraulico volumetrico incrociato - doppio cilindro - rampe portanti - <b>sicura idraulica</b> - potenza motore 2.2kw - 400V/3PH/50Hz
<b>GT-DSM 4.0 MASTER</b> MECHANICAL LOCK	4.0 T	1420 X 680	2000 X 680	115 - 1950	Low profile electrohydraulic double scissor lift - <b>mechanical lock</b> - anti knock valve - Volumetric crossed hydraulic system - double cylinder - load bearing ramps - engine power 2.2kw - 400V/3PH Sollevatore elettro-idraulico a doppia forbice a basso profilo - valvola paracadute - impianto idraulico volumetrico incrociato - doppio cilindro - rampe portanti - <b>sicura meccanica</b> - potenza motore 2.2kw - 400V/3PH/50Hz

All models are provided with 4 rubber buffers. All our product are supplied with sandblasting  
STANDARD COLOURS: GREY RAL 7016 - GREY RAL 7040

Tutti i modelli vengono forniti con 4 tamponi in gomma. Su tutti i ponti viene applicato il trattamento di sabbiatura  
COLORI STANDARD: GRIGIO RAL 7016 - GRIGIO RAL 7040



# OPTIONAL

CODE	DESCRIPTION	
<b>B-93014</b>	Expansion bolts set (8 pz) - Set tasselli di fissaggio (8pz)	
<b>B-93021</b>	Wires-pipes extension set L= +1 m - Set estensioni tubi-cavi L= +1 m	
<b>B-93022</b>	Wires-pipes extension set L= +2 m - Set estensioni tubi-cavi L= +2 m	
<b>B-93023</b>	Wires-pipes extension set L= +3 m - Set estensioni tubi-cavi L= +3 m	
<b>A-93019</b>	Set rubber pad H= 60 mm (4 pz) - Set tamponi H= 60 mm (4 pz)	
<b>A-93039</b>	Rubber ramps H=30mm - Rampe in gomma H=30mm	ONLY FOR FLOOR VERSION / SOLO PER VERSIONE A PAVIMENTO
<b>A-93040</b>	Rubber ramps H=50mm - Rampe in gomma H=50mm	ONLY FOR FLOOR VERSION / SOLO PER VERSIONE A PAVIMENTO



MECHANICAL SAFETY LOCK  
SICURA MECCANICA



LOAD BEARING RAMPS  
RAMPE PORTANTI

**3.000 Kg**

**3.500 Kg**

**4.000 Kg**

# GT - DS MASTER

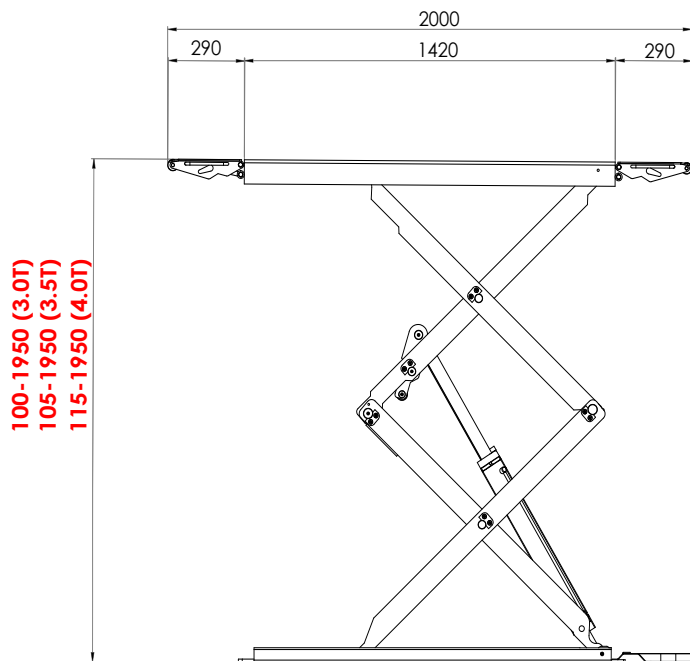

**3.000 Kg**

**3.500 Kg**

**4.000 Kg**

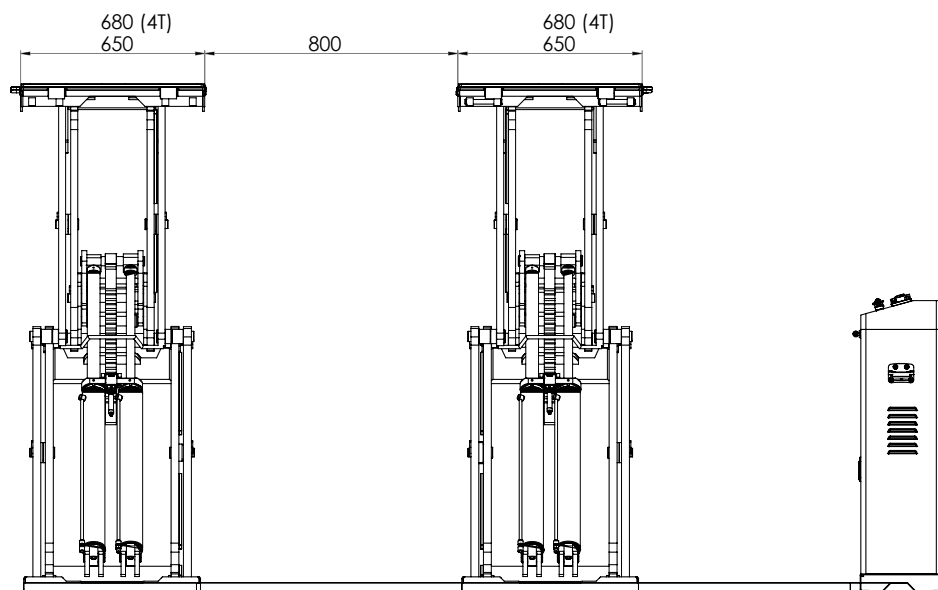

**Available with / Disponibile con:**

**Mechanical safety lock**  
**Sicura meccanica**

**or**

**Hydraulic safety lock**  
**Sicura idraulica**

# GT - DS MASTER

- 1** PHOTOCCELL FOR MISALIGNMENT  
FOTOCPELLULA ANTI DISALLINEAMENTO
- 2** APPROACHING RAMPS  
RAMPE SALITA
- 3** MECHANICAL SAFETY LOCK  
SICURA MECCANICA
- 4** DOUBLE CYLINDER MASTER/SLAVE  
DOPPIO CILINDRO MASTER/SLAVE
- 5** PNEUMATIC CYLINDER  
CILINDRO PNEUMATICO
- 6** RACK  
CREMAGLIERA
- 7** PINS WITH SELF-LUBRICATING BUSHES  
PERNI CON BOCCOLE AUTOLUBRIFICANTI
- 8** AVAILABLE: MECHANICAL SAFETY LOCK  
OR HYDRAULIC SAFETY LOCK  
DISPONIBILE: VERSIONE CON SICURA MECCANICA  
O SICURA IDRAULICA



CONTROL UNIT WITH DOUBLE ACCESS F/R  
CENTRALINA CON DOPPIO - ACCESSO F/R

RUBBER RAMPS H=30/50mm  
RAMPA IN GOMMA H=30/50mm  
OPTIONAL

# GT - DS 3.0 DE

**3.000 Kg**



Low profile electrohydraulic double scissor lift - anti knock valve - pneumatic released with safety lock - double cylinder - standard engine power 2,2 KW/400V/3PH/50Hz - on request: 2,2 KW - 220V/1PH/50Hz - Required pneumatic connection for safe release 6/8 bar (RECESSED VERSION)

Sollevatore elettro-idraulico a doppia forbice ad alto profilo con estensioni pedana - sicura meccanica - sgancio pneumatico - potenza motore 2.2 KW - 400V/3PH/50HZ - Richiesta connessione pneumatica per lo sgancio sicure 6/8 bar (VERSIONE A INCASSO)

MODEL	LIFT CAPACITY	PLATFORM (mm)	PLATFORM WITH RAMPS	LIFTING HIGHT	DESCRIPTION
GT-DS 3.0 DE	3.0 T	1440 x 550	2040 x 550	330 - 2100	Electrohydraulic double scissor lift - HIGH profile - double platform extension for various kind of vehicles - engine power 2.2 kw/400V/3PH/50Hz Sollevatore elettroidraulico a doppia forbice ad incasso - alto profilo - doppia estensione pedana per veicoli di vario tipo - potenza motore 2.2 kw/400V/3PH/50Hz



All models are provided with 4 rubber buffers. All our product are supplied with sandblasting.  
STANDARD COLOURS: GREY RAL 7016 - GREY RAL 7040

Tutti i modelli vengono forniti con 4 tamponi in gomma. Su tutti i ponti viene applicato il trattamento di sabbiatura  
COLORI STANDARD: GRIGIO RAL 7016 - GRIGIO RAL 7040



# OPTIONAL

CODE	DESCRIPTION	
<b>B-93014</b>	Expansion bolts set (8 pz) - Set tasselli di fissaggio (8pz)	
<b>B-93021</b>	Wires-pipes extension set L= +1 m - Set estensioni tubi-cavi L= +1 m	
<b>B-93022</b>	Wires-pipes extension set L= +2 m - Set estensioni tubi-cavi L= +2 m	
<b>B-93023</b>	Wires-pipes extension set L= +3 m - Set estensioni tubi-cavi L= +3 m	
<b>A-93019</b>	Set rubber pad H= 60 mm (4 pz) - Set tamponi H= 60 mm (4 pz)	
<b>A-93039</b>	Rubber ramps H=30mm - Rampe in gomma H=30mm	ONLY FOR FLOOR VERSION / SOLO PER VERSIONE A PAVIMENTO
<b>A-93040</b>	Rubber ramps H=50mm - Rampe in gomma H=50mm	ONLY FOR FLOOR VERSION / SOLO PER VERSIONE A PAVIMENTO

## GT - DS 3.0 DE DOUBLE EXTENSION

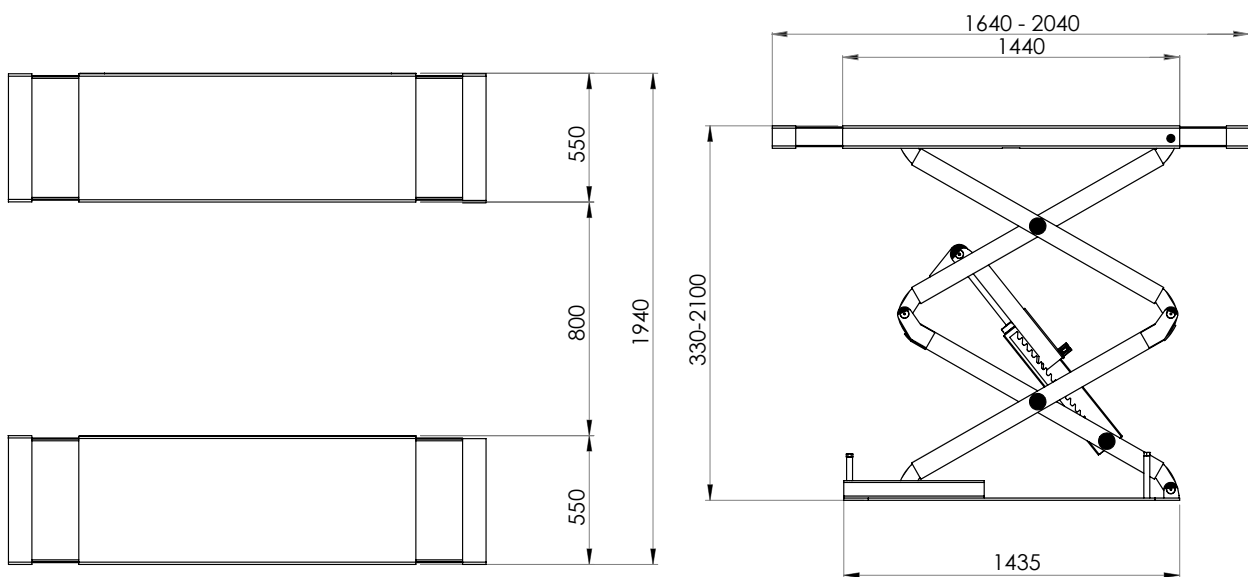

MECHANICAL LOCK  
SICURA MECCANICA



SUV KIT  
SUV KIT

# GT - MR 3.0

**3.000 Kg**

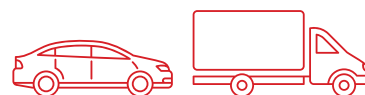

Mid-rise electrohydraulic scissor lift with double manual alignment and anti-knock valve - Double cylinder - Lifting height: 105 - 960 mm - standard engine power 2,2KW - 400V/3 PH/50 Hz - on request: 2,2KW - 220V/1 PH/50Hz.  
(ON FLOOR OR RECESSED VERSION)

Sollevatore elettroidraulico per gommisti portata 3T- valvola paracadute - doppio cilindro - Altezza di sollevamento: 105 - 960 mm - Potenza motore standard 2.2KW - 400V/3PH/50HZ a richiesta: 2,2KW - 220V/1 PH/50Hz.  
(VERSIONE A PAVIMENTO O A INCASSO)

MODEL	LIFT CAPACITY	PLATFORM (mm)	PLATFORM WITH RAMPS	LIFTING HIGHTT	DESCRIPTION
GT-MR 3.0	3.0 T	1450 x 530	2036 x 530	105 - 960	Electrohydraulic lift - anti knock valve - Volumetric crossed hydraulic system - double cylinder - load bearing ramps Sollevatore elettro-idraulico per gommisti - valvola paracadute - impianto idraulico volumetrico incrociato - doppio cilindro - rampe portanti

MIDE RISE LIFT  
SOLLEVATORE MEDIA ALTEZZA



**3.000 Kg**



LOAD BEARING RAMPS  
RAMPE PORTANTI



DOUBLE CYLINDER  
DOPPIO CILINDRO

**OPTIONAL**

<b>CODE</b>	<b>DESCRIPTION</b>
<b>B-93014</b>	Expansion bolts set (8 pz) - Set tasselli di fissaggio (8pz)
<b>B-93021</b>	Wires-pipes extension set L= +1 m - Set estensioni tubi-cavi L= +1 m
<b>B-93022</b>	Wires-pipes extension set L= +2 m - Set estensioni tubi-cavi L= +2 m
<b>B-93023</b>	Wires-pipes extension set L= +3 m - Set estensioni tubi-cavi L= +3 m
<b>A-93019</b>	Set rubber pad H= 60 mm (4 pz) - Set tamponi H= 60 mm (4 pz)
<b>A-93039</b>	Rubber ramps H=30mm - Rampe in gomma H=30mm <small>ONLY FOR FLOOR VERSION / SOLO PER VERSIONE A PAVIMENTO</small>
<b>A-93040</b>	Rubber ramps H=50mm - Rampe in gomma H=50mm <small>ONLY FOR FLOOR VERSION / SOLO PER VERSIONE A PAVIMENTO</small>

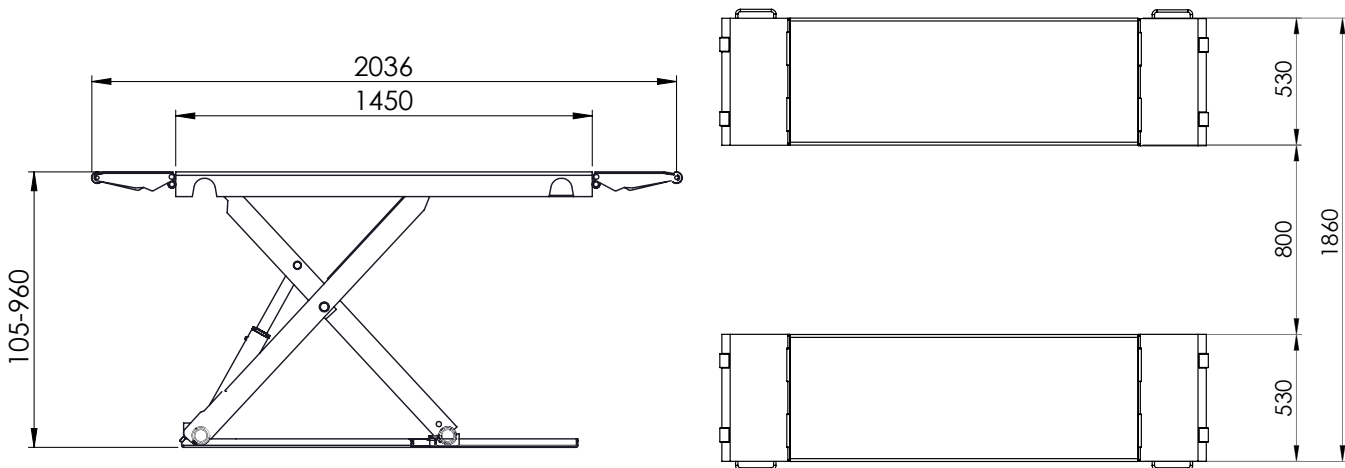

All models are provided with 4 rubber buffers. All our product are supplied with sandblasting.

STANDARD COLOURS: GREY RAL 7016 - GREY RAL 7040

Tutti i modelli vengono forniti con 4 tamponi in gomma. Su tutti i ponti viene applicato il trattamento di sabbiatura

COLORI STANDARD: GRIGIO RAL 7016 - GRIGIO RAL 7040

# GT - MR 3.0 MOBILE



Mid-rise electrohydraulic scissor lift with anti-knock valve - double cylinder - Lifting height: 105 - 960 mm - standard engine power 2,2 KW - 400V/3PH/50Hz - on request: 2,2KW - 220V/1 PH/50Hz . (ON FLOOR VERSION)

Sollevatore elettroidraulico per gommisti portata - valvola paracadute - doppio cilindro - Altezza di sollevamento: 105 - 960mm - Potenza motore 2.2KW - 400V/3PH/50Hz a richiesta: 2,2KW - 220V/1 PH/50Hz. (VERSIONE A PAVIMENTO)

MODEL	LIFT CAPACITY	PLATFORM (mm)	PLATFORM LENGTH WITH	LIFTING HEIGHT	DESCRIPTION
GT-MR 3.0 MOBILE	3.0 T	1450 x 530	2036 x 530	105 - 960	Electrohydraulic lift - anti knock valve - volumetric crossed hydraulic system - double cylinder - load bearing ramps - mobile version Sollevatore elettroidraulico per gommisti - valvola paracadute - impianto idraulico volumetrico incrociato - doppio cilindro - rampe portanti - versione mobile



**3.000 Kg**

All models are provided with 4 rubber buffers. All our product are supplied with sandblasting.  
STANDARD COLOURS: GREY RAL 7016 - GREY RAL 7040

Tutti i modelli vengono forniti con 4 tamponi in gomma. Su tutti i ponti viene applicato il trattamento di sabbiatura  
COLORI STANDARD: GRIGIO RAL 7016 - GRIGIO RAL 7040



# OPTIONAL

CODE	DESCRIPTION
<b>B-93014</b>	Expansion bolts set (8 pz) - Set tasselli di fissaggio (8pz)
<b>B-93021</b>	Wires-pipes extension set L= +1 m - Set estensioni tubi-cavi L= +1 m
<b>B-93022</b>	Wires-pipes extension set L= +2 m - Set estensioni tubi-cavi L= +2 m
<b>B-93023</b>	Wires-pipes extension set L= +3 m - Set estensioni tubi-cavi L= +3 m
<b>A-93019</b>	Set rubber pad H= 60 mm (4 pz) - Set tamponi H= 60 mm (4 pz)
<b>A-93039</b>	Rubber ramps H=30mm - Rampe in gomma H=30mm <small>ONLY FOR FLOOR VERSION / SOLO PER VERSIONE A PAVIMENTO</small>
<b>A-93040</b>	Rubber ramps H=50mm - Rampe in gomma H=50mm <small>ONLY FOR FLOOR VERSION / SOLO PER VERSIONE A PAVIMENTO</small>

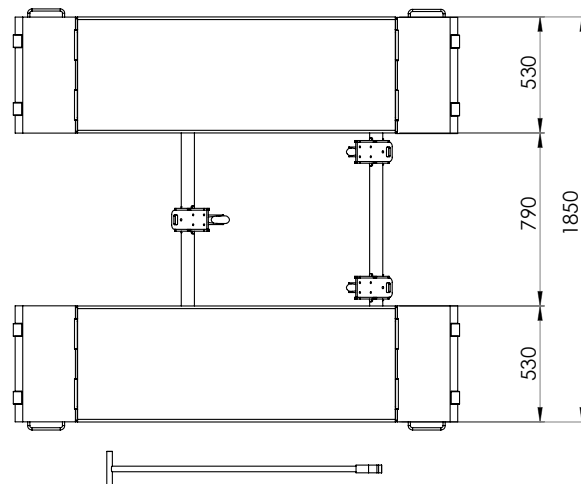
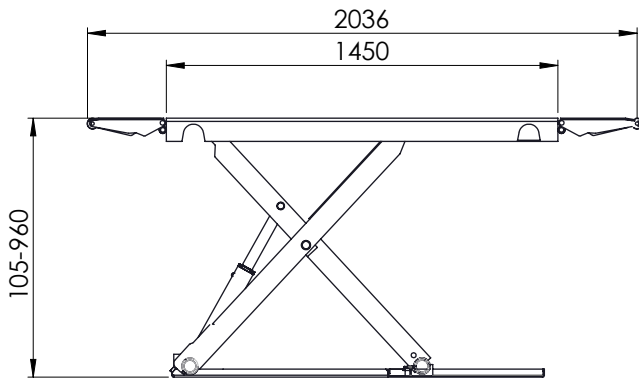

LOAD BEARING RAMPS  
RAMPE PORTANTI



DOUBLE CYLINDER  
DOPPIO CILINDRO



RUBBER RAMPS H=30/50mm  
RAMPA IN GOMMA H=30/50mm  
OPTIONAL

# GT - FP 3.5 - 4.5 - 5.5



Four post electrohydraulic lift ideal for 3D technology wheel alignment - 2 independent ropes - pneumatic release with safety lock - with anti-knock valve - standard rolling jack rails - standard engine power 2,2KW - 400V/3PH /50 Hz - on request: 2,2 KW - 220 V/1PH/50Hz - Pneumatic connection for safe release required 6/8 bar

Sollevatore elettroidraulico 4 colonne ideale per assetto ruote a tecnologia 3D - 2 funi indipendenti - valvola paracadute - corsia standard rolling jack - potenza motore 2.2/3.0kw - 400V/3PH/50Hz - a richiesta 2,2 KW - 220V/1PH/50Hz - richiesta connessione aria per lo sgancio sicure 4/8bar

MODEL	CAPACITY	PLATFORM (mm)	COLUMNS BETWEEN	LIFTING HEIGHT	DESCRIPTION
<b>GT - FPA 3.5</b>	3.5 T	4260 x 490	2564	220 - 1820	Front recess 685mm - for wheel alignment - sliding plates 1400mm - anti knock valve Incavo anteriore 685mm - piano oscillante 1400mm - valvola paracadute
<b>GT - FPF 3.5</b>	3.5 T	4260 x 490	2564	170 - 1770	Flat platform - anti knock valve Pedana piana a basso profilo - valvola paracadute
<b>GT - FPA 4.5</b>	4.5 T	5190 x 490	2742	246 - 1896	Front recess 1065mm - sliding plates 1400mm - anti knock valve - for wheel alignment Incavo anteriore 1065mm - piano oscillante 1400mm - valvola paracadute
<b>GT - FPF 4.5</b>	4.5 T	5190 x 490	2742	196 - 1846	Flat platform - anti knock valve Pedana piana - valvola paracadute
<b>GT - FPA 5.5</b>	5.5 T	5190 x 490	2742	246 - 1896	Front recess 1065mm - sliding plates 1400mm - anti knock valve - for wheel alignment Incavo anteriore 1065mm - piano oscillante 1400mm - valvola paracadute
<b>GT - FPF 5.5</b>	5.5 T	5190 x 490	2742	196 - 1846	Flat platform - anti knock valve Pedana piana - valvola paracadute

STANDARD: ROLLING JACK RAILS - STANDARD: CORSIE ROLLING JACK



On request, all the platforms of the GT-FPA models can be provided with turning plates, and rolling jack. All our product are supplied with sandblasting. STANDARD COLOURS: GREY RAL 7016 - GREY RAL 7040

A richiesta tutte le pedane dei modelli GT-FPA possono ospitare piatti rotanti e rolling jack.

Su tutti i ponti viene applicato il trattamento di sabbatura. COLORI STANDARD: GRIGIO RAL 7016 - GRIGIO RAL 7040

# OPTIONAL

CODE	DESCRIPTION
<b>B-93014</b>	Expansion bolts set (16 pz) - Set tasselli di fissaggio (16pz)
<b>A-93039</b>	Rubber ramps H=30mm - Rampe in gomma H=30mm <span style="float: right;">ONLY FOR FLOOR VERSION / SOLO PER VERSIONE A PAVIMENTO</span>
<b>A-93040</b>	Rubber ramps H=50mm - Rampe in gomma H=50mm <span style="float: right;">ONLY FOR FLOOR VERSION / SOLO PER VERSIONE A PAVIMENTO</span>

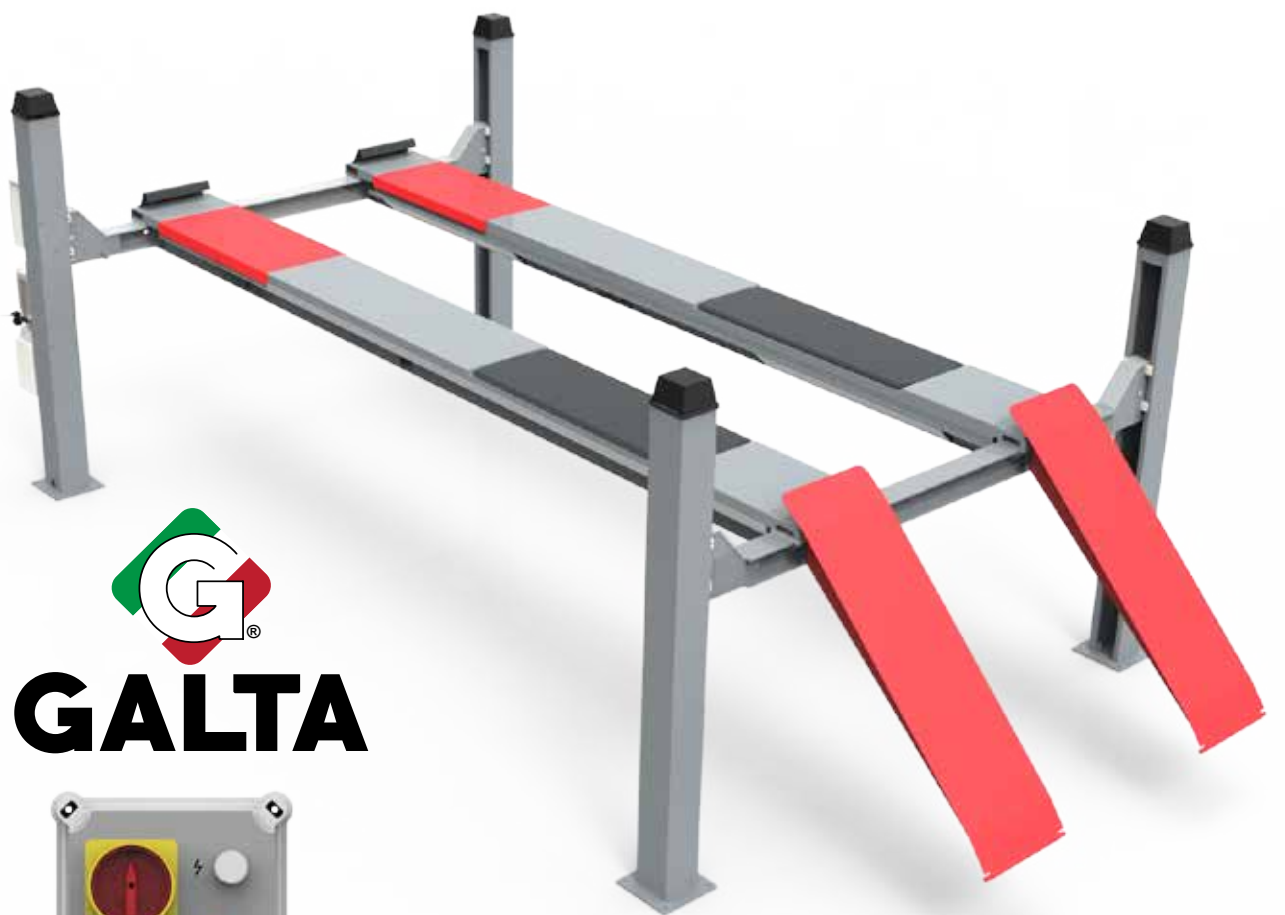

RUBBER RAMPS H=30mm  
RAMPA IN GOMMA H=30mm  
OPTIONAL



RUBBER RAMPS H=50mm  
RAMPA IN GOMMA H=50mm  
OPTIONAL

# GT - FPA 3.5 - 4.5 - 5.5

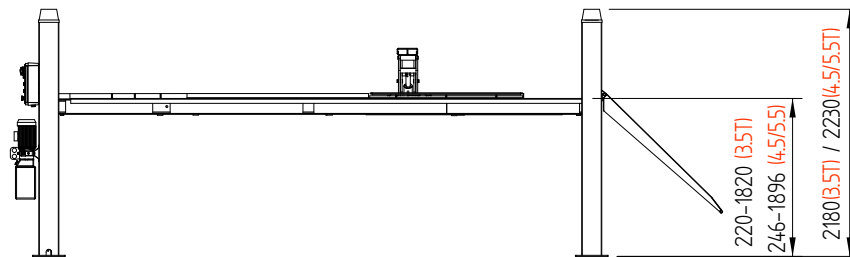

**3.500 Kg**

**4.500 Kg**

**5.500 Kg**

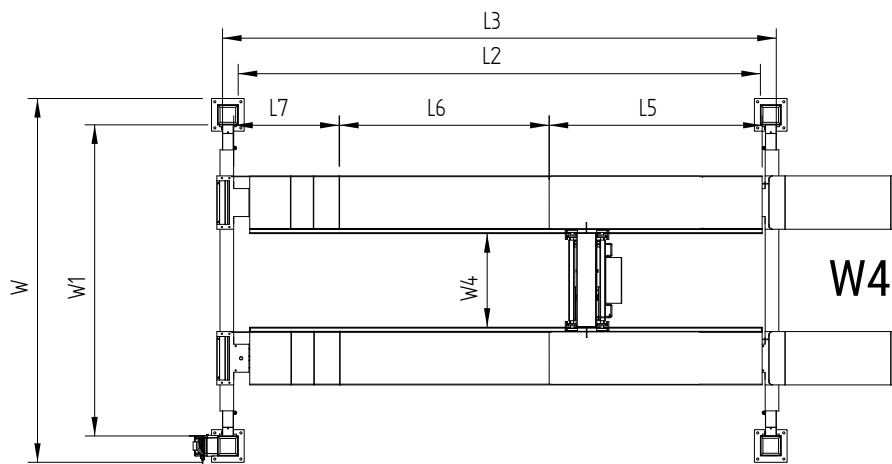

W4=Standard 800mm

CODE	L	L1	L2	L3	L4	L5	L6	L7	W	W1	W2	W3	W4	H	H1	H2
<b>GT - FPA 3.5</b>	5206	4372	3812	4260	280	1400	1677	685	3124	2564	490	280	<b>800 - 1100</b>	2180	1820	220
<b>GT - FPA 4.5</b>	6288	5303	4703	5190	300	1400	1700	1065	3342	2860	490	300	<b>800 - 1100</b>	2230	1896	246
<b>GT - FPA 5.5</b>	6288	5303	4703	5190	300	1400	1700	1065	3342	2860	490	300	<b>800 - 1100</b>	2230	1896	246





# GT - FPF 3.5 - 4.5 - 5.5

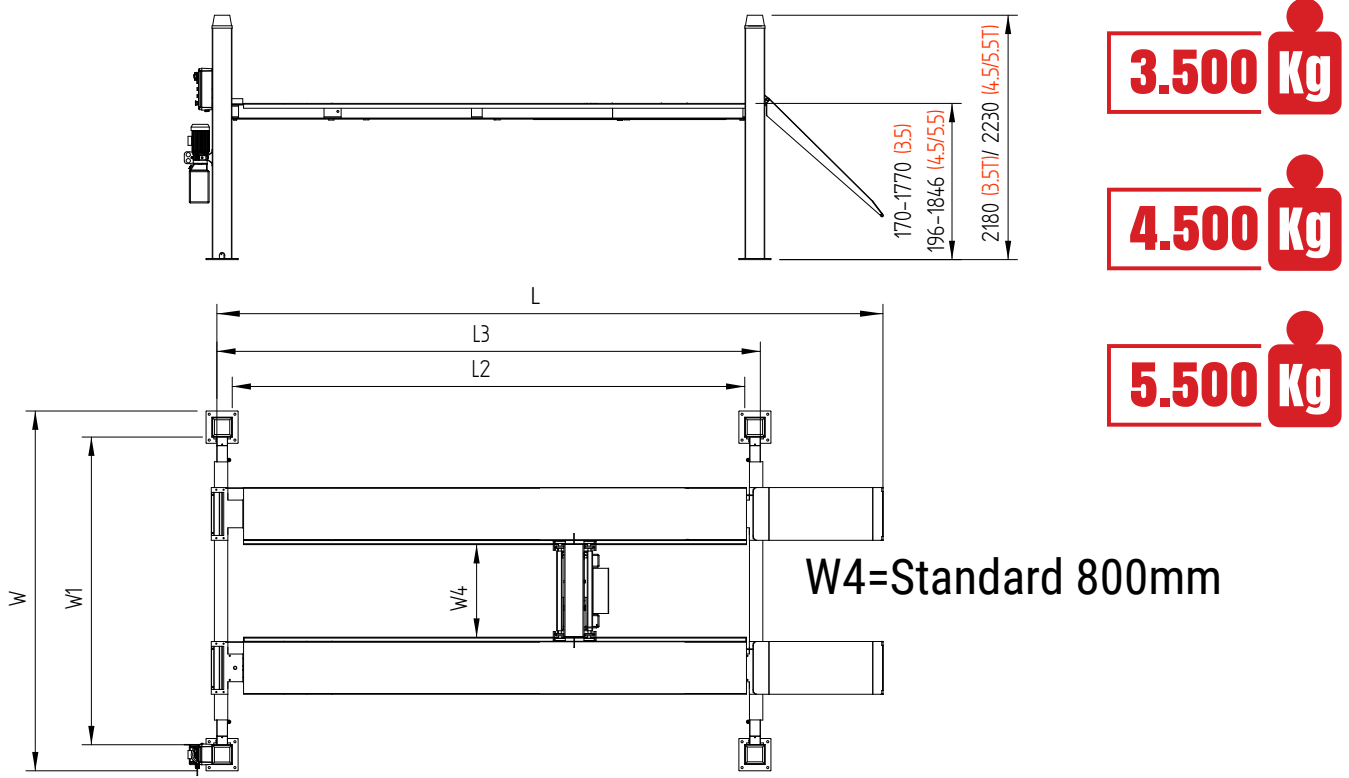

## CODE

	L	L1	L2	L3	L4	L5	L6	L7	W	W1	W2	W3	W4	H	H1	H2
<b>GT - FPF 3.5</b>	5206	4372	3812	4260	280	1400	1677	685	3124	2564	490	280	800 - 1100	2180	1760	170
<b>GT - FPF 4.5</b>	6288	5303	4703	5190	300	1400	1700	1065	3342	2860	490	300	800 - 1100	2230	1846	196
<b>GT - FPF 5.5</b>	6288	5303	4703	5190	300	1400	1700	1065	3342	2860	490	300	800 - 1100	2230	1846	196



# GT - FPA-LT 5.0



Four post electrohydraulic lift with lift table, ideal for 3D technology wheel alignment - 2 independent ropes - pneumatic safety release - anti knock valve - Lift table capacity 3500kg - Sliding plates with manual release - engine power 2.2 KW - 400V/3PH/50Hz on request 220V/1PH - Pneumatic connection for safety release required 6/8 bar

Sollevatore elettroidraulico 4 colonne con torretta ideale per assetto ruote a tecnologia 3D - 2 funi indipendenti - sgancio sicuro pneumatico - valvola paracadute - Lift table portata 3500kg - Piano scillante con blocco manuale - Potenza motore 2.2 KW - 400V/3PH/50Hz a richiesta 220V/1PH - Richiesta connessione pneumatica 6/8 bar.

MODEL	CAPACITY	PLATFORM (mm)	LT CAPACITY	COLUMNS BETWEEN	LIFTING HEIGHT	DESCRIPTION
GT- FPA - LT	5000 Kg	5190 X 640	3500 Kg	2826	250 - 1890	Front recess 1025mm - lift table 1450÷2160mm - rear recess 1912mm - anti knock valve - Sliding plates - engine power 2.2kw - 400V/3PH Incavo anteriore 1025 mm - lift table 1450÷2160mm - incavo posteriore 1912mm - valvola paracadute - Piani oscillanti - potenza motore 2.2kw - 400V/3PH /50Hz

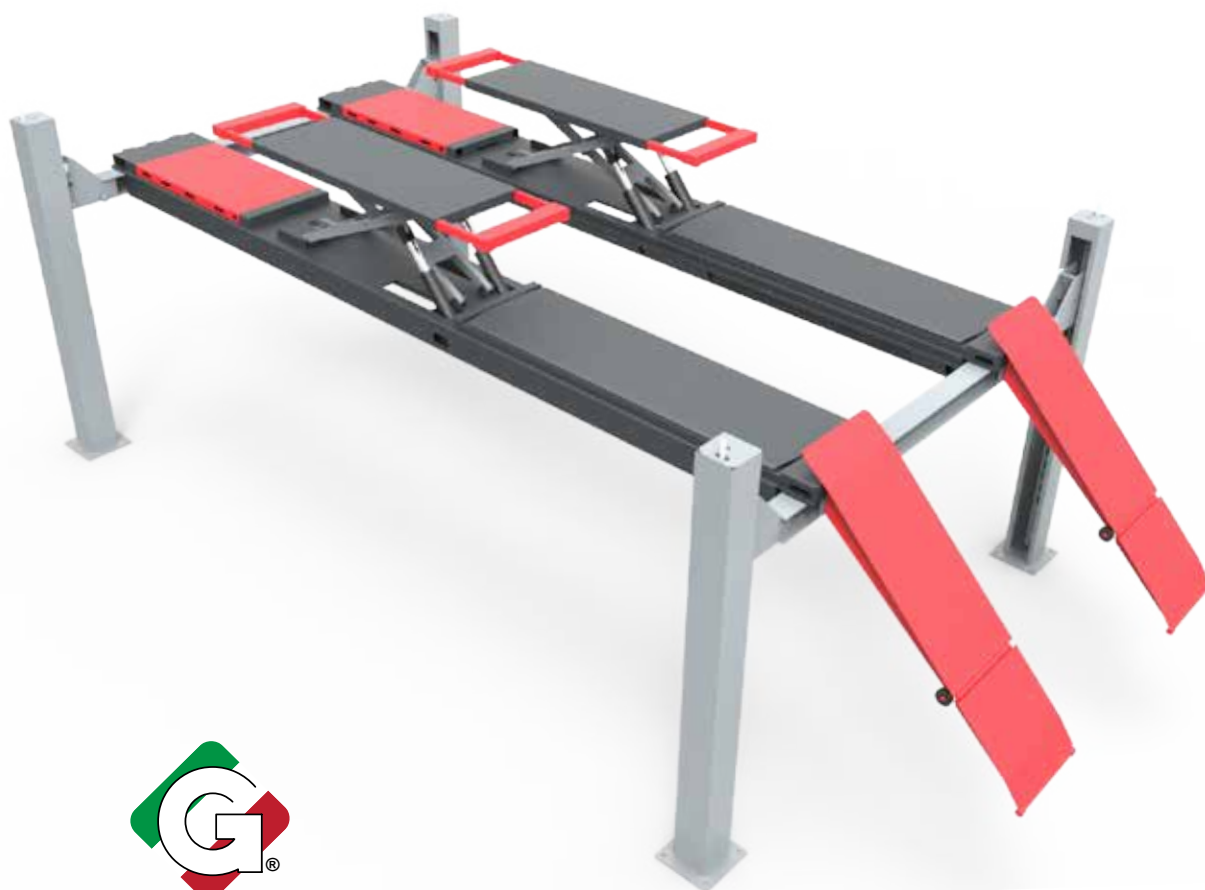

All our products are supplied with sandblasting.  
STANDARD COLOURS: GREY RAL 7016 - GREY RAL 7040

Su tutti i ponti viene applicato il trattamento di sabbiatura.  
COLORI STANDARD: GRIGIO RAL 7016 - GRIGIO RAL 7040

# OPTIONAL

CODE	DESCRIPTION
<b>B-93014</b>	Expansion bolts set (16 pz) - Set tasselli di fissaggio (16pz)
<b>A-93039</b>	Rubber ramps H=30mm - Rampe in gomma H=30mm <span style="float: right;">ONLY FOR FLOOR VERSION / SOLO PER VERSIONE A PAVIMENTO</span>
<b>A-93040</b>	Rubber ramps H=50mm - Rampe in gomma H=50mm <span style="float: right;">ONLY FOR FLOOR VERSION / SOLO PER VERSIONE A PAVIMENTO</span>

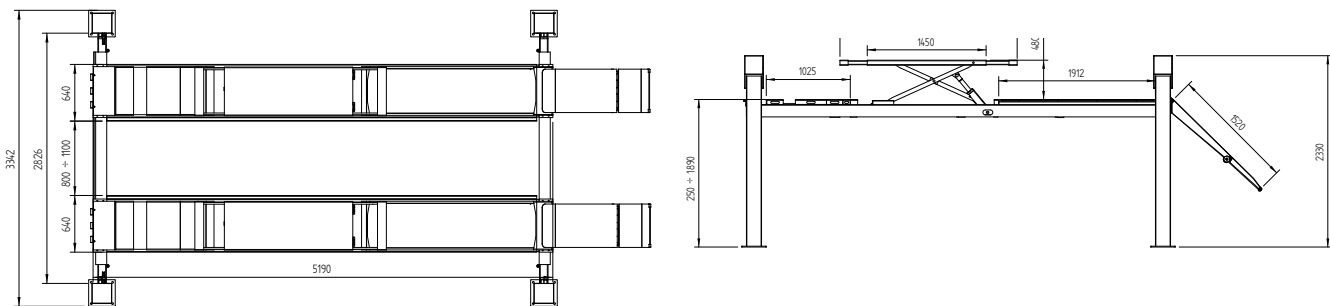

STANDARD: ROLLING JACK RAILS - STANDARD: CORSIE ROLLING JACK



LIFT TABLE WITH PNEUMATIC RELEASE  
LIFT TABLE CON SGANCIO PNEUMATICO



LIFT TABLE WITH DOUBLE EXTENSION  
LIFT TABLE CON DOPPIA ESTENSIONE



DOUBLE APPROACHING RAMPS  
RAMPE SALITA DOPPIE



ROLLING JACK 2T/3T  
ROLLING JACK 2T/3T



RUBBER RAMPS H=30/50mm  
RAMPA IN GOMMA H=30/50mm  
OPTIONAL



LIFT TABLE WITH 2 EXTENSIONS  
LIFT TABLE CON 2 ESTENSIONI

# GT - TPB 4.0 BASEMENT

Two Post Electrohydraulic lift - 2 pushing cylinders directly connected to the chained carriages - 4 mechanical safety locks with electric release - engine power 2.2KW - 400V/3PH/50Hz - On request 2.2KW - 230V/1PH/50Hz

Sollevatore elettroidraulico 2 colonne indipendenti - 2 cilindri in spinta connessi direttamente ai carrelli con catena - sgancio sicuro elettrico - 4 sicure meccaniche - potenza motore 2.2KW - 400V/3PH/50Hz - A richiesta 2.2KW - 230V/1PH/50Hz

MODEL	CAPACITY	COLUMN (mm)	COLUMN HEIGHT	LIFTING HEIGHT	DESCRIPTION
<b>GT- TPB 4.0 BASEMENT</b>	4.0 T	2918	2780	126 - 1900	Electrohydraulic lift with supporting basement - short front extension arms (min 680/max1030) - long rear extension arms (min 830/max 1380) Sollevatore elettroidraulico a 2 colonne indipendenti con basamento portante - bracci anteriori corti a doppio sfilo (min 680/max1030) - bracci posteriori lunghi a doppio sfilo (min 830/max 1380)

**1** LOAD BEARING BASEMENT  
BASAMENTO PORTANTE

**2** RUBBER PROTECTION  
PROTEZIONE IN GOMMA

**3** DOUBLE ELECTROMAGNETIC SAFETY RELEASE  
DOPPIO ELETTROMAGNETE

**4** STEEL CABLE FOR MISALIGNMENT  
CAVI DI ACCIAIO ANTI DISALLINEAMENTO





# OPTIONAL

CODE	DESCRIPTION
------	-------------

**B-93014** Expansion bolts set (14 pz) - Set tasselli di fissaggio (14 pz)

**A-93033** Extension pad kit - Kit prolunghe tamponi 60mm - 160mm

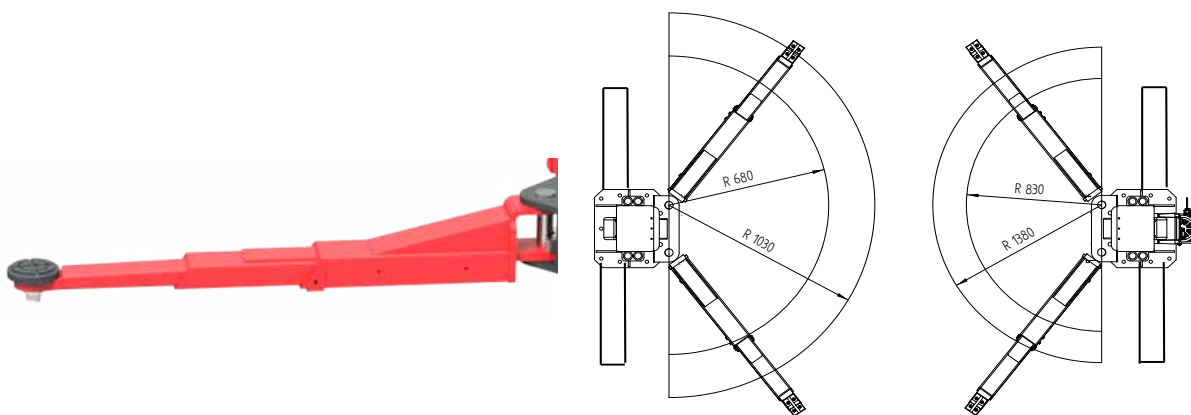
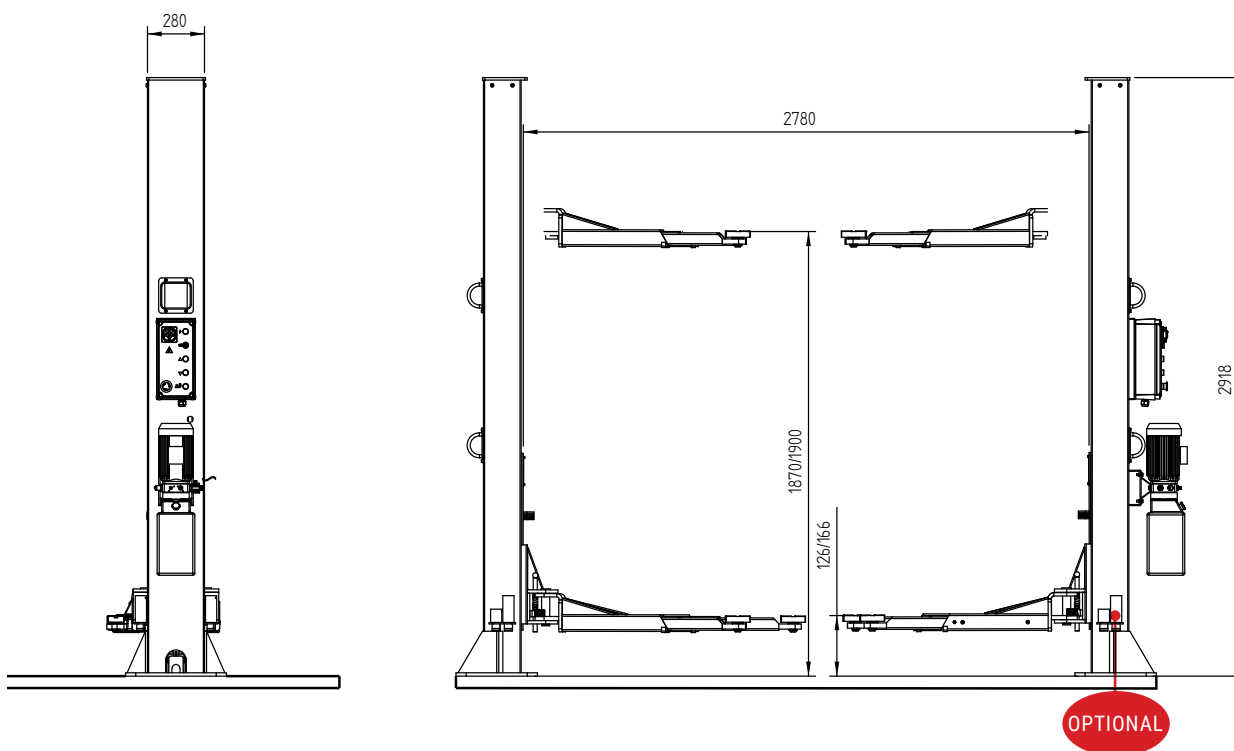

STANDARD VERSION - DOUBLE EXTENSION ARM  
VERSIONE STANDARD - BRACCI A DOPPIO SFILÒ

All our products are supplied with sandblasting.  
STANDARD COLOURS: GREY RAL 7016 - GREY RAL 7040

Su tutti i ponti viene applicato il trattamento di sabbiatura.  
COLORI STANDARD: GRIGIO RAL 7016 - GRIGIO RAL 7040

# GT - TP 4.0 AIR



Two Post Electrohydraulic lift - 2 pushing cylinders directly connected to the chained carriages - 4 mechanical safety locks with electric release - engine power 2.2kw - 400V/3PH/50Hz - On request 2.2KW - 230V/1PH/50Hz

Sollevatore elettroidraulico - 2 colonne indipendenti - 2 cilindri in spinta connessi direttamente ai carrelli con catena - sgancio elettrico - 4 sicure meccaniche - potenza motore 2.2kw - 400V/3PH/50Hz - A richiesta 2.2KW - 230V/1PH/50Hz

MODEL	CAPACITY	COLUMN (mm)	COLUMN HIGHT	LIFTING HIGHT	DESCRIPTION
GT- TP 4.0 AIR	4.0 T	2878	2780	105 - 1890	Electrohydraulic lift with on ground still cables/pipes/wires cover - short front extension arms (min 680/max1030) - long rear extension arms (min 830/max 1380) Sollevatore elettroidraulico a 2 colonne indipendenti e canalina passatubi/cavi a pavimento - bracci anteriori corti a doppio filo (min 680/max 1030) - bracci posteriori lunghi a doppio filo (min 830/max 1380)

- 1** PIPES COVER  
CANALINA COPRITUBI
- 2** EXTENSION PAD (optional)  
PROLUNGHE TAMPONE (optional)
- 3** DOUBLE ELECTROMAGNETIC SAFETY RELEASE  
DOPPIO ELETTROMAGNETE
- 4** STEEL CABLE FOR MISALIGNMENT  
CAVI DI ACCIAIO PER L' ANTI DISALLINEAMENTO



**OPTIONAL**

CODE	DESCRIPTION
------	-------------

**B-93014** Expansion bolts set (14 pz) - Set tasselli di fissaggio (14 pz)

**A-93033** Extension pad kit - Kit prolunghe tamponi 60mm - 160mm

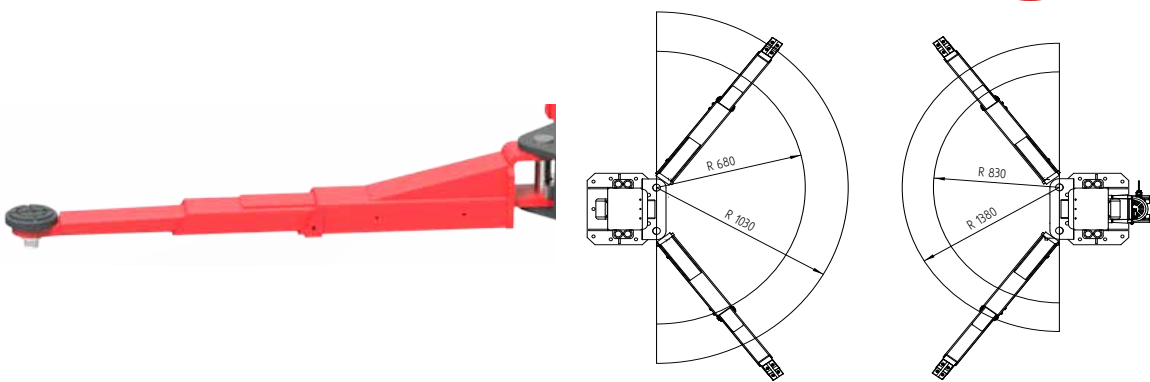
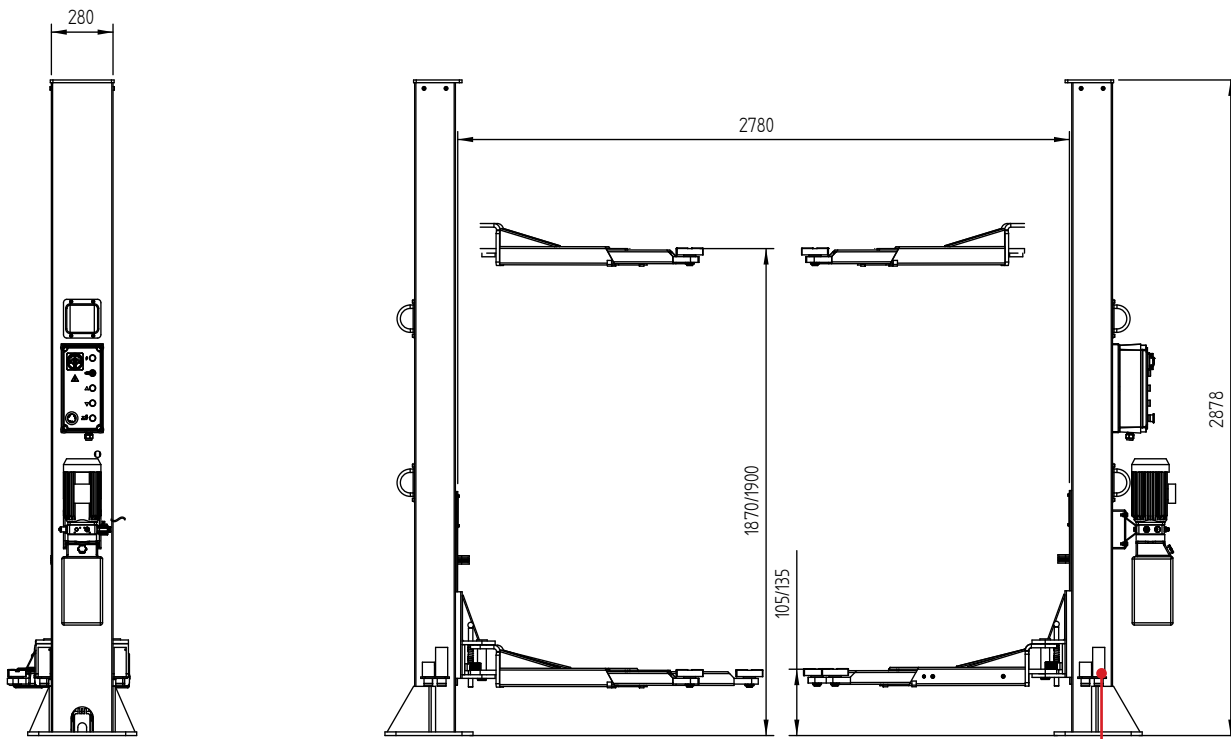

STANDARD VERSION - DOUBLE EXTENSION ARM  
VERSIONE STANDARD - BRACCI A DOPPIO SFILÒ

All our products are supplied with sandblasting.  
STANDARD COLOURS: GREY RAL 7016 - GREY RAL 7040

Su tutti i ponti viene applicato il trattamento di sabbiatura.  
COLORI STANDARD: GRIGIO RAL 7016 - GRIGIO RAL 7040

# GT - TP 4.0 TOP



Two posts lift with upper connection - hydraulic drive - 2 pushing cylinders directly connected to the carriages - mechanical safety lock with electric release - standard engine power 2,2 KW - 400 V/3 PH/50 Hz - on request: 2,2 KW - 220 V/1 PH/50 Hz

Sollevatore elettro-idraulico 2 colonne con connessione aerea - trasmissione idraulica - 2 cilindri in spinta connessi direttamente ai carrelli - sgancio elettrico - sicure meccaniche - potenza motore 2.2KW - 400V/3PH/50Hz - A richiesta 2.2KW - 230V/1PH/50Hz

MODEL	CAPACITY	COLUMN (mm)	COLUMN HIGHT	LIFTING HIGHT	DESCRIPTION
GT- TP 4.0 TOP	4.0 T	3876	2800	105 - 1890	2 posts electrohydraulic lift with supporting crossbeam - short front extension arms (min 680/max1030) - long rear extension arms ( min 830/ max 1380) Sollevatore elettro-idraulico a 2 colonne con traversa portante - bracci anteriori corti a doppio filo (min 680/max 1030) - bracci posteriori lunghi a doppio filo (min 830/max 1380)

- 1** ANTICOLLISION BAR  
BARRA ANTI COLLISIONE
- 2** EXTENSION PAD (optional)  
PROLUNGHE TAMPONE (optional)
- 3** ELECTROMAGNETIC SAFETY RELEASE  
ELETTROMAGNETE SGANCIO SICURE
- 4** STEEL CABLE FOR MISALIGNMENT  
CAVI DI ACCIAIO PER L' ANTI DISALLINAMENTO



**4.000 Kg**





# OPTIONAL

CODE	DESCRIPTION
<b>B-93014</b>	Expansion bolts set (14 pz) - Set tasselli di fissaggio (14 pz)
<b>A-93033</b>	Extension pad kit - Kit prolunghe tamponi 60mm - 160mm

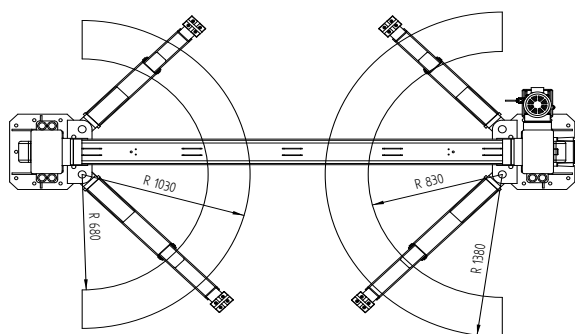
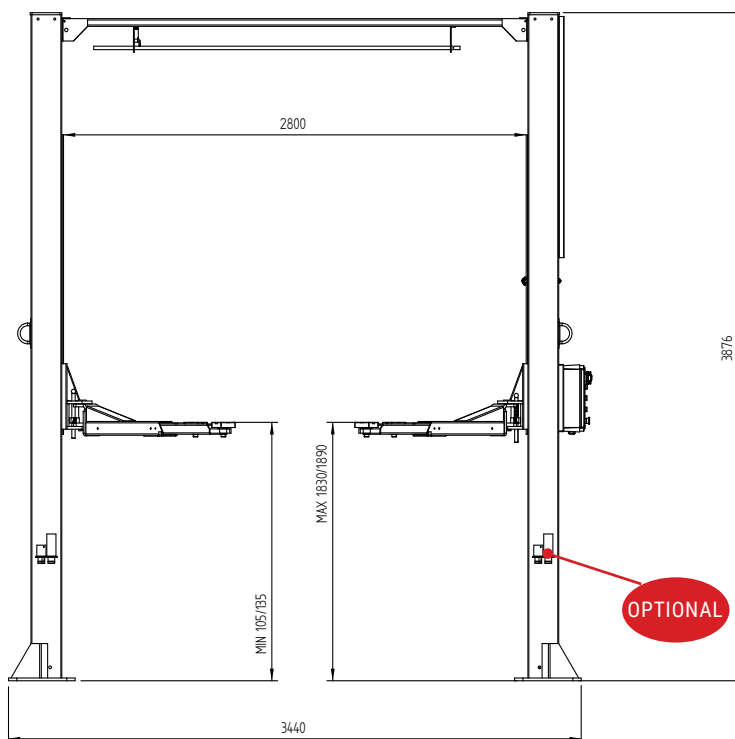
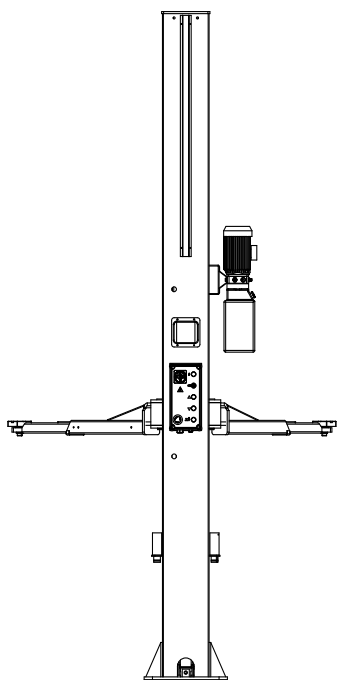

## STANDARD VERSION - DOUBLE EXTENSION ARM VERSIONE STANDARD - BRACCI A DOPPIO SFILÒ

All our product are supplied with sandblasting.  
STANDARD COLOURS: GREY RAL 7016 - GREY RAL 7040

Su tutti i ponti viene applicato il trattamento di sabbiatura.  
COLORI STANDARD: GRIGIO RAL 7016 - GRIGIO RAL 7040

# GT - TP 4.0 TOP M



Two posts lift with upper connection - hydraulic drive - 2 pushing cylinders directly connected to the carriages - mechanical safety lock with MANUAL release - standard engine power 2,2 KW - 400 V/3 PH/50 Hz - on request: 2,2 KW - 220 V/1 PH/50 Hz

Sollevatore elettro-idraulico 2 colonne con connessione aerea - trasmissione idraulica - 2 cilindri in spinta connessi direttamente ai carrelli - sgancio MANUALE- sicure meccaniche - potenza motore 2.2KW - 400V/3PH/50Hz - A richiesta 2.2KW - 230V/1PH/50Hz

MODEL	CAPACITY	COLUMN (mm)	COLUMN HIGHT	LIFTING HIGHT	DESCRIPTION
GT- TP 4.0 TOP M	4.0 T	3596	2800	115-1700	2 posts electrohydraulic lift with supporting crossbeam - short front extension arms (min 680/max1020) - long rear extension arms ( min 860/ max 1300) Sollevatore elettro-idraulico a 2 colonne con traversa portante - bracci anteriori corti a doppio filo (min 680/max 1020) - bracci posteriori lunghi a doppio filo (min 860/max 1300)

- 1** ANTICOLLISION BAR  
BARRA ANTI COLLISIONE
- 2** MANUAL SAFETY RELEASE  
SGANCIO SICURE MANUALE
- 3** STEEL CABLE FOR MISALIGNMENT  
CAVI DI ACCIAIO PER L' ANTI DISALLINAMENTO



**4.000 Kg**



# OPTIONAL

CODE	DESCRIPTION
------	-------------

**B-93014** Expansion bolts set (14 pz) - Set tasselli di fissaggio (14 pz)

**A-93033** Extension pad kit - Kit prolunghe tamponi 60mm - 160mm

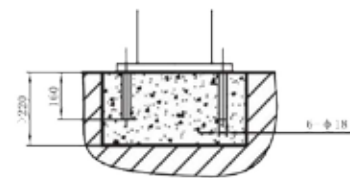
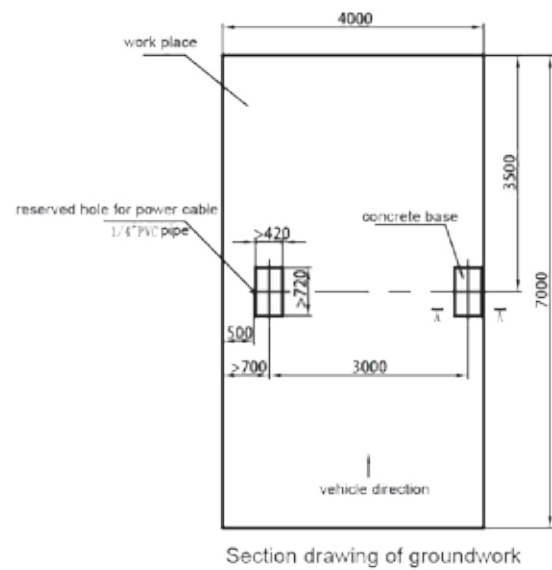
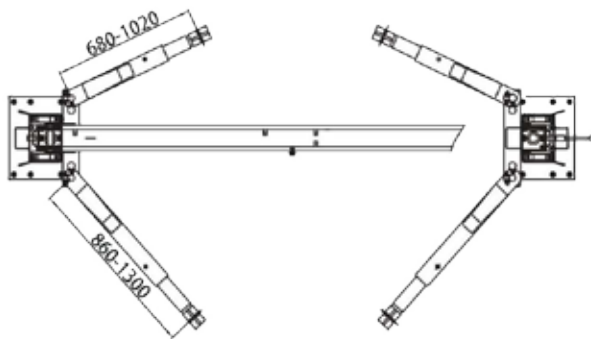
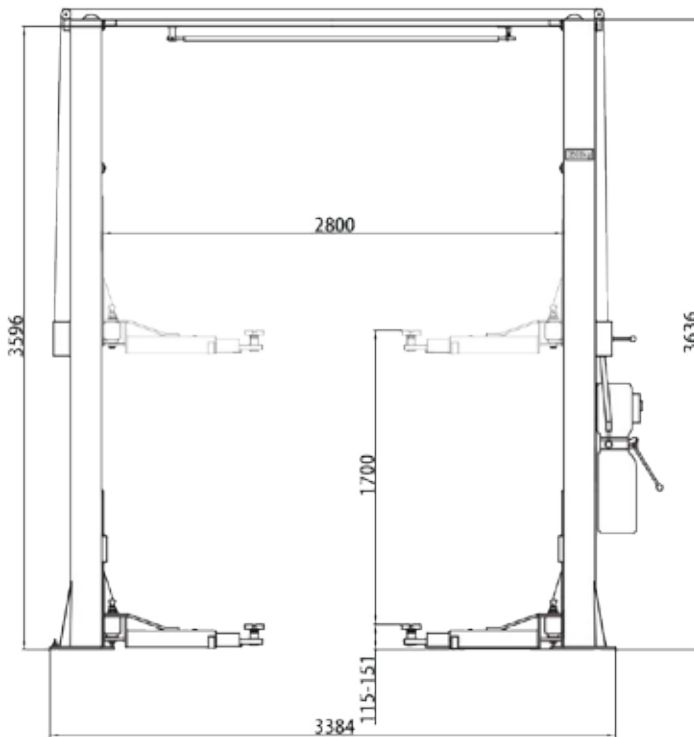

All our product are supplied with sandblasting.  
STANDARD COLOURS: GREY RAL 7016 - GREY RAL 7040

Su tutti i ponti viene applicato il trattamento di sabbiatura.  
COLORI STANDARD: GRIGIO RAL 7016 - GRIGIO RAL 7040

# GT - TP 4.0 AIR M



Two Post Electrohydraulic lift - 2 pushing cylinders directly connected to the chained carriages - 2 mechanical safety locks with MANUAL release - engine power 2.2kw - 400V/3PH/50Hz - On request 2.2KW - 230V/1PH/50Hz

Sollevatore elettroidraulico - 2 colonne indipendenti - 2 cilindri in spinta connessi direttamente ai carrelli con catena - sgancio MANUALE sicure - 2 sicure meccaniche - potenza motore 2.2kw - 400V/3PH/50Hz - A richiesta 2.2KW - 230V/1PH/50Hz

MODEL	CAPACITY	COLUMN (mm)	COLUMN HIGHT	LIFTING HIGHT	DESCRIPTION
GT- TP 4.0 AIR M	4.0 T	2700	2728	115-1860	Electrohydraulic lift with on ground still cables/pipes/wires cover - short front extension arms (min 700/max1060) - long rear extension arms (min 760/max 1210) Sollevatore elettroidraulico a 2 colonne indipendenti e canalina passatubi/cavi a pavimento - bracci anteriori corti a doppio filo (min 700/max 1060) - bracci posteriori lunghi a doppio filo (min 760/max 1210)

1

PIPES COVER  
CANALINA COPRITUBI

2

MANUAL SAFETY RELEASE  
SGANCIO SICURA MANUALE

3

STEEL CABLE FOR MISALIGNMENT  
CAVI DI ACCIAIO PER L' ANTI DISALLINAMENTO



**4.000** Kg



**OPTIONAL**

CODE	DESCRIPTION
------	-------------

**B-93014** Expansion bolts set (14 pz) - Set tasselli di fissaggio (14 pz)

**A-93033** Extension pad kit - Kit prolunghe tamponi 60mm - 160mm

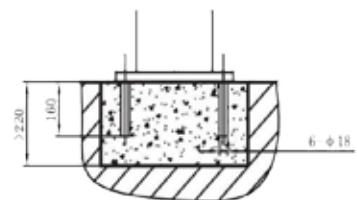
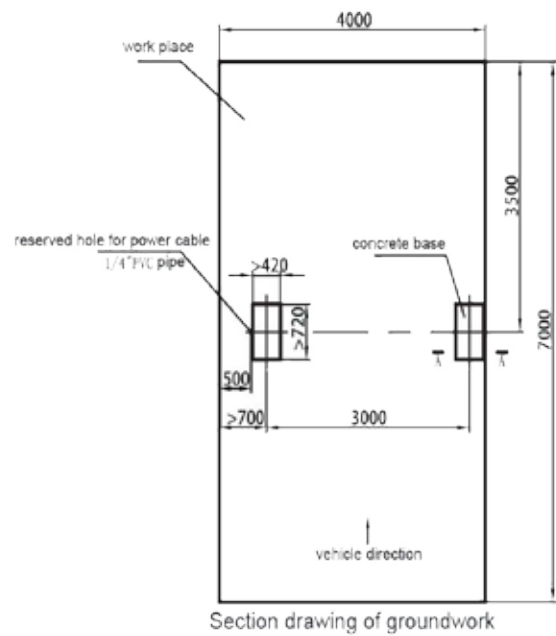
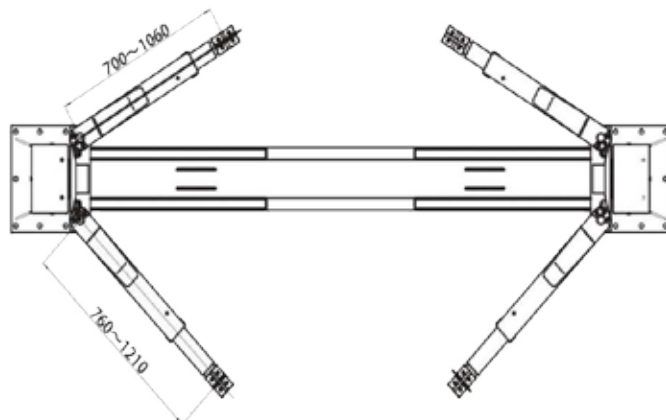
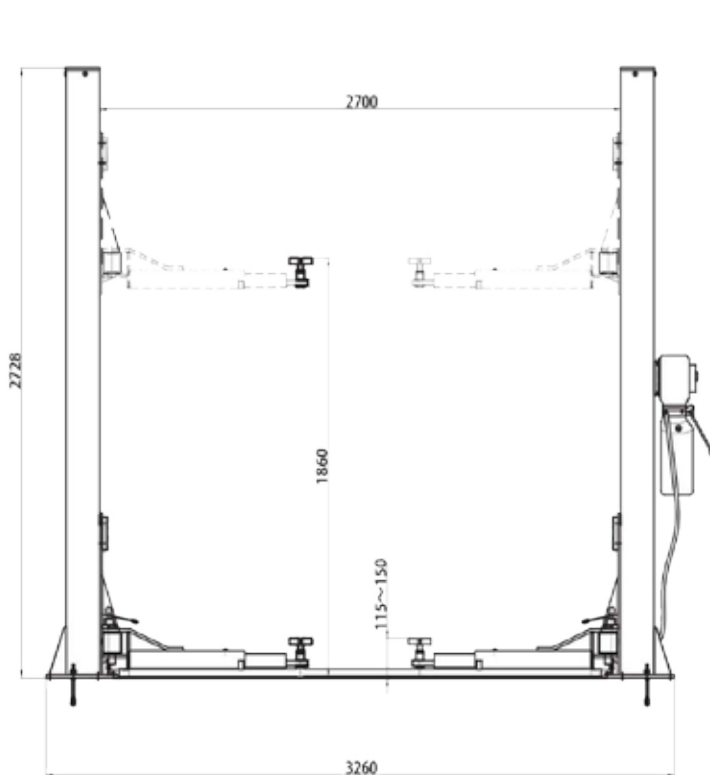

All our products are supplied with sandblasting.  
STANDARD COLOURS: GREY RAL 7016 - GREY RAL 7040

Su tutti i ponti viene applicato il trattamento di sabbiatura.  
COLORI STANDARD: GRIGIO RAL 7016 - GRIGIO RAL 7040

## GT-SC 3.0

One Post Electrohydraulic lift - 1 pushing cylinders directly connected to the chained carriage - 1 mechanical safety locks with electric release - engine power 2.2KW - 230V/1PH/50HZ

Sollevatore elettroidraulico - 1 colonna indipendente - 1 cilindro in spinta connesso direttamente al carrello con catena - sgancio elettrico - 1 sicura meccanica - potenza motore 2.2KW - 230V/1PH/50HZ



**3.000 Kg**

All our product are supplied with sandblasting.  
STANDARD COLOURS: GREY RAL 7016 - GREY RAL 7040

Su tutti i ponti viene applicato il trattamento di sabbiatura.  
COLORI STANDARD: GRIGIO RAL 7016 - GRIGIO RAL 7040

## TECHNICAL FEATURES - DATI TECNICI

Max lift capacity Portata massima di sollevamento	3000 Kg
Operating height: Altezza operativa	85 - 1930 mm
Standard Weight Peso standard	750 Kg

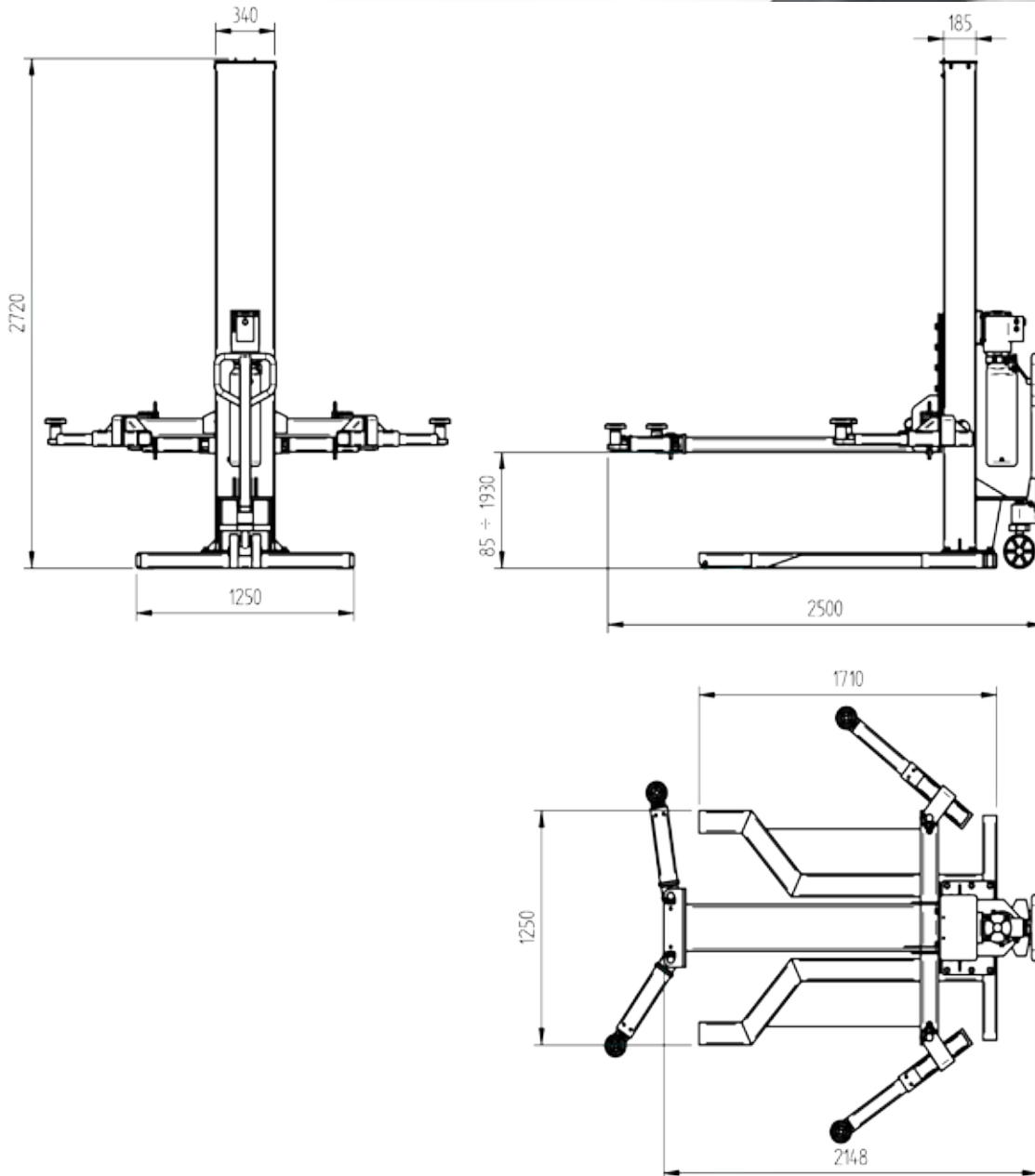

# GT-TP 2.8

# GT-TP 2.8 B

ELECTRO-HYDRAULIC PARKING LIFT - 2 CYLINDERS CONNECTED DIRECTLY TO THE PLATFORM - MECHANICAL SAFE RELEASE WITH ELECTROMAGNET - MAXIMUM HEIGHT SENSOR - 2.2KW MOTOR POWER - 400V / 3PH / 50HZ - 230V / 1PH / 50HZ

Sollevatore elettroidraulico da parcheggio - 2 cilindri connessi direttamente alla pedana - sgancio sicura meccanica con elettromagnete - sensore di massima altezza - potenza motore 2.2KW - 400V/3PH/50HZ - 230V/1PH/50HZ



**2.800 Kg**



All our product are supplied with sandblasting.  
STANDARD COLOURS: GREY RAL 7016 - GREY RAL 7040

Su tutti i ponti viene applicato il trattamento di sabbiatura.  
COLORI STANDARD: GRIGIO RAL 7016 - GRIGIO RAL 7040



## TECHNICAL FEATURES - DATI TECNICI

Max lift capacity Portata massima di sollevamento	2800 Kg
Operating height: Altezza operativa	110 - 2100 mm
Standard Weight Peso standard	1400 Kg

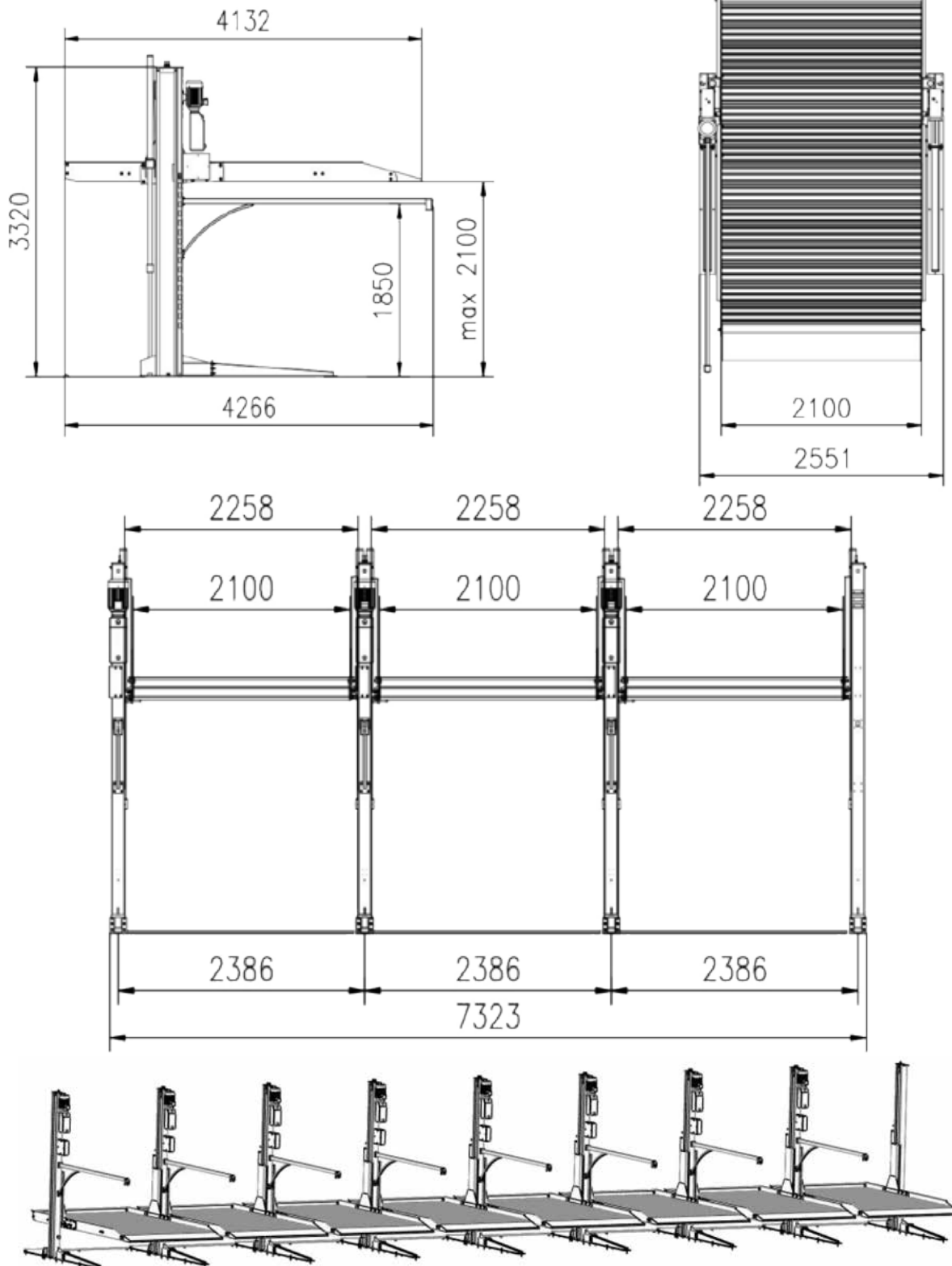

8 units to be installed together

# GT - RJ

**2.000 Kg** **3.000 Kg**

MODEL	CAPACITY	PLATFORM (mm)	PLATFORM WITH EXTENSIONS	LIFTING HIGHT	DESCRIPTION
GT - RJ2M	2 T	860	1400	275	Auxiliary lift for scissor lift and 4 post lifts - with adjustable upper platform with 2 extensions 860-1400mm and adjustable base for every lift 780-1100mm - Minimum height 185 mm - <b>MANUAL PUMP</b> Traversa ausiliaria per sollevatori a forbice/4 colonne con pedana superiore regolabile con 2 estensioni 860-1400mm e base regolabile per ogni ponte 780-1100mm - Altezza minima 185 mm - <b>POMPA MANUALE</b>
GT - RJ2P	2 T	860	1400	275	Auxiliary lift for scissor lift and 4 post lifts with adjustable upper platform with 2 extensions 860-1400mm and adjustable base for every lift 780-1100mm - Minimum height 185 mm - <b>PNEUMO-HYDRAULIC PUMP - (6/8 bar)</b> Traversa ausiliaria per sollevatori a forbice/4 colonne con pedana superiore regolabile con 2 estensioni 860-1400mm e base regolabile per ogni ponte 780-1100mm - Altezza minima 185 mm - <b>POMPA PNEUMO-IDRAULICA</b> ingresso 6/8 bar
GT - RJ3P	3 T	860	1400	275	Auxiliary lift for scissor lift and 4 post lifts - with adjustable upper platform with 2 extensions 860-1400mm and adjustable base for every lift 780-1100mm - Minimum height 185 mm. <b>PNEUMO-HYDRAULIC PUMP - (6/8 bar)</b> Traversa ausiliaria per sollevatori a forbice/4 colonne con pedana superiore regolabile con 2 estensioni 860-1400mm e base regolabile per ogni ponte 780-1100mm - Altezza minima 185 mm - <b>POMPA PNEUMO-IDRAULICA</b> ingresso 6/8 bar

**1** SAFETY RELEASE  
SGANCIO SICURA

**3** SECURITY TOOTH  
DENTE DI SICUREZZA

**2** PLATFORM EXTENSION  
ESTENSIONE PEDANA

**4** BEARING WHEELS  
RULLI DI SCORRIMENTO PORTANTI



PNEUMO-HYDRAULIC PUMP  
POMPA PNEUMOIDRAULICA



MANUAL PUMP  
POMPA MANUALE

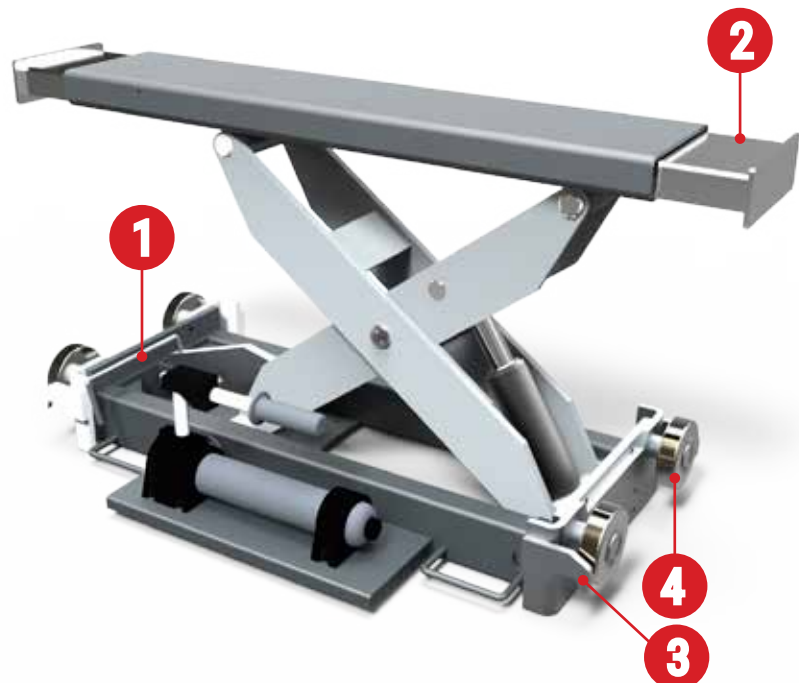

All our product are supplied with sandblasting. STANDARD COLOURS: GREY RAL 7016 - GREY RAL 7040  
Su tutti i ponti viene applicato il trattamento di sabbiatura. COLORI STANDARD: GRIGIO RAL 7016 - GRIGIO RAL 7040

# GT - MJ

## MANUAL OR PNEUMOHYDRAULIC VERSION VERSIONE MANUALE O PNEUMOIDRAULICA

With an ultra compact style MJ offers the possibility to raise and lower the engine of cars, vans and campers in total safety thanks to the attacks of the platform designed for all engines on the market.

Con uno stile ultra compatto MJ offre la possibilità di alzare e abbassare il motore di auto, furgoni e camper in totale sicurezza grazie agli attacchi della piattaforma studiata per tutti i motori in commercio.



PNEUMO-HYDRAULIC PUMP  
POMPA PNEUMOIDRAULICA

**2.000 Kg**

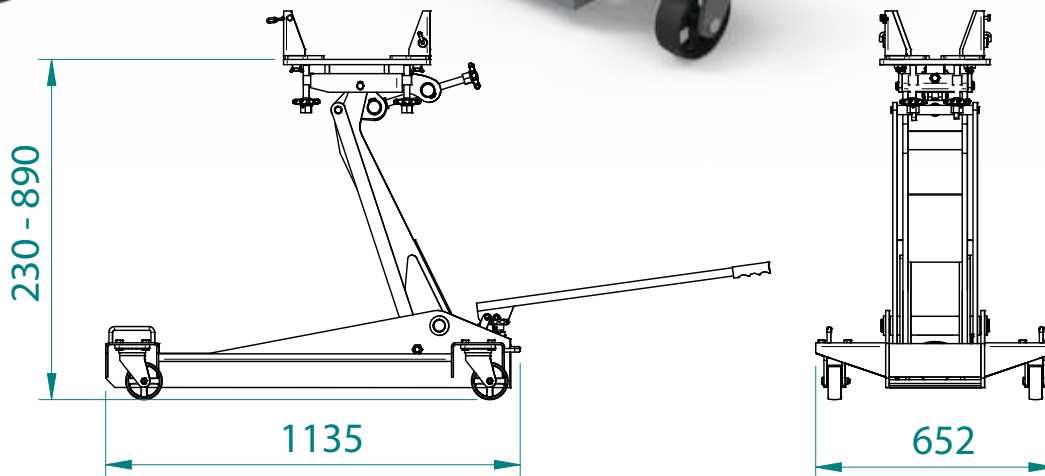

### TECHNICAL FEATURES - DATI TECNICI

Max lift capacity Portata massima di sollevamento	2000 Kg
Operating height: Altezza operativa	230 - 890 mm
Standard Weight Peso standard	135 Kg
Dimension dimensioni	1135mm x 650mm x 265mm

# GT - BATTERY LIFT

It facilitates the management of the charge-discharge of the batteries in the new electric cars. made of resistant steel that can handle loads up to 1000 kg. the battery pack can be easily loaded on the trolley platform, lowered to a safe transport height and raised again to unload everything at its destination. They have a pump controlled by a push-button panel.

Facilita la gestione del carico-scarico delle batterie nelle nuove auto elettriche. costruiti in acciaio resistente che può gestire carichi fino a 1000 kg. il pacco batterie può essere facilmente caricato sulla piattaforma del carrello, abbassati ad un'altezza di trasporto sicura e sollevati di nuovo per scaricare il tutto a destinazione. Dispongono di una pompa comandata da una pulsantiera.



**1.000 Kg**

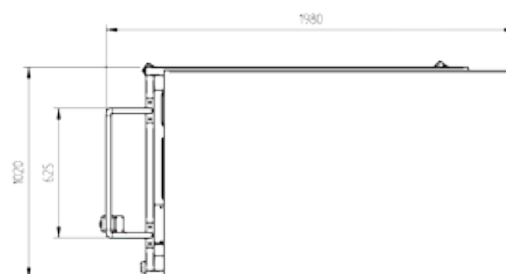
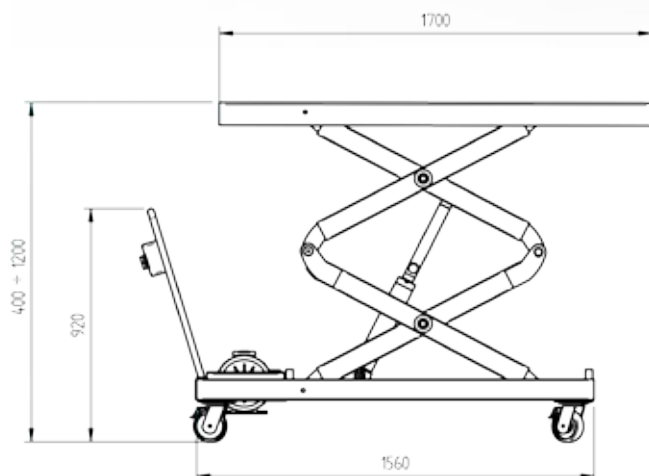
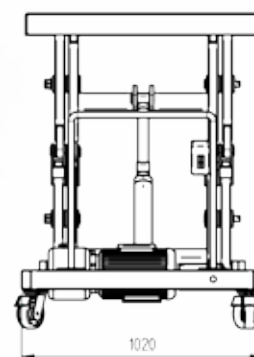

## TECHNICAL FEATURES - DATI TECNICI

Max lift capacity Portata massima di sollevamento	1000 Kg
Operating height: Altezza operativa	400- 1200 mm
Standard Weight Peso standard	350 Kg



# GT - MC 600



Motorcycle lifter up to 600kg solid steel structure with a minimum height of only 200mm control of the hydraulic pump with cable remote control. Pneumatic clamp for front wheels

Sollevatore per moto fino a 600kg. solida struttura in acciaio con una altezza minima di solo 200mm comando della pompa idraulica con telecomando via cavo. Morsa pneumatica per ruote anteriori.

**600 Kg**



## TECHNICAL FEATURES - DATI TECNICI

Max lift capacity Portata massima di sollevamento	600 Kg
Operating height: Altezza operativa	200 - 800 mm
Standard platform measures (LxW) Misure standard (Lunghezza x larghezza)	2130 x 750 mm
Standard Weight Peso standard	150 Kg
Pneumatic Power Azionamento Pneumatico	6/8 bar

# GT - 3.0 SB

Low profile electrohydraulic scissor lift with extension - anti knock valve - pneumatic released with safety lock - standard engine power 2,2 KW/400V/3PH/50Hz - on request: 2,2 KW - 220V/1PH/50Hz. Required pneumatic connection for safe release 6/8 bar (RECESSED VERSION)

Sollevatore elettro-idraulico a forbice ad alto profilo con estensioni - sicura meccanica - sgancio pneumatico - potenza motore 2.2 KW - 400V/3PH/50Hz. Richiesta connessione pneumatica per lo sgancio sicure 6/8 bar (VERSIONE A INCASSO)

**3.000 Kg**



## TECHNICAL FEATURES - DATI TECNICI

Max lift capacity Portata massima di sollevamento	3000 Kg
Operating height: Altezza operativa	260 ÷ 1730 mm
Standard platform measures (LxW) Misure standard (Lunghezza x larghezza)	2360 x 700 mm
Measures + extension (LxW) Misure con estensioni (Lunghezza x larghezza)	2836 x 1610 mm
Standard Weight Peso standard	750 Kg
Hydraulic Power Azionamento idraulico	220 bar

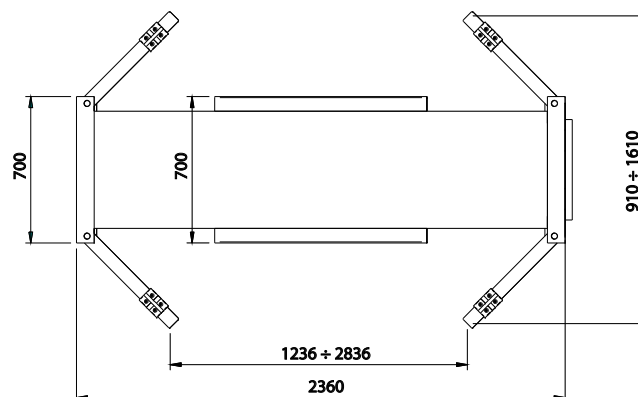
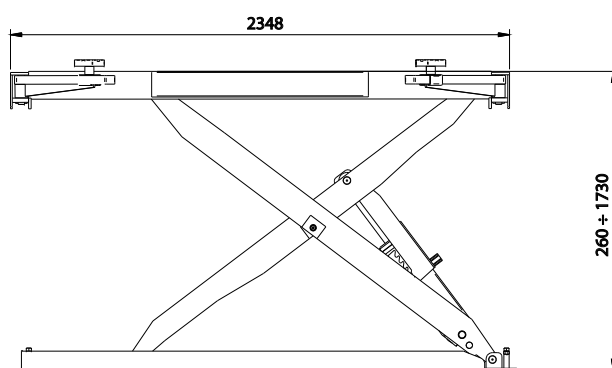

# GT - 3.0 SBS

Low profile electrohydraulic scissor lift with double cylinder with extension - anti knock valve - pneumatic released with safety lock - standard engine power 2,2 KW/400V/3PH/50Hz - on request: 2,2 KW - 220V/1PH/50Hz. Required pneumatic connection for safe release 6/8 bar (RECESSED VERSION)

Sollevatore elettro-idraulico a forbice doppio cilindro con estensioni - sicura meccanica - sgancio pneumatico - potenza motore 2.2 KW - 400V/3PH/50Hz. Richiesta connessione pneumatica per lo sgancio sicuro 6/8 bar (VERSIONE A INCASSO)

**3.000 Kg**



## TECHNICAL FEATURES - DATI TECNICI

Max lift capacity Portata massima di sollevamento	3000 Kg
Operating height: Altezza operativa	125 ÷ 1300 mm
Standard platform measures (LxW) Misure standard (Lunghezza x larghezza)	1900 x 880 mm
Measures + extension (LxW) Misure con estensioni (Lunghezza x larghezza)	2303 x 1668 mm
Standard Weight Peso standard	550 Kg
Hydraulic Power Azionamento idraulico	220 bar

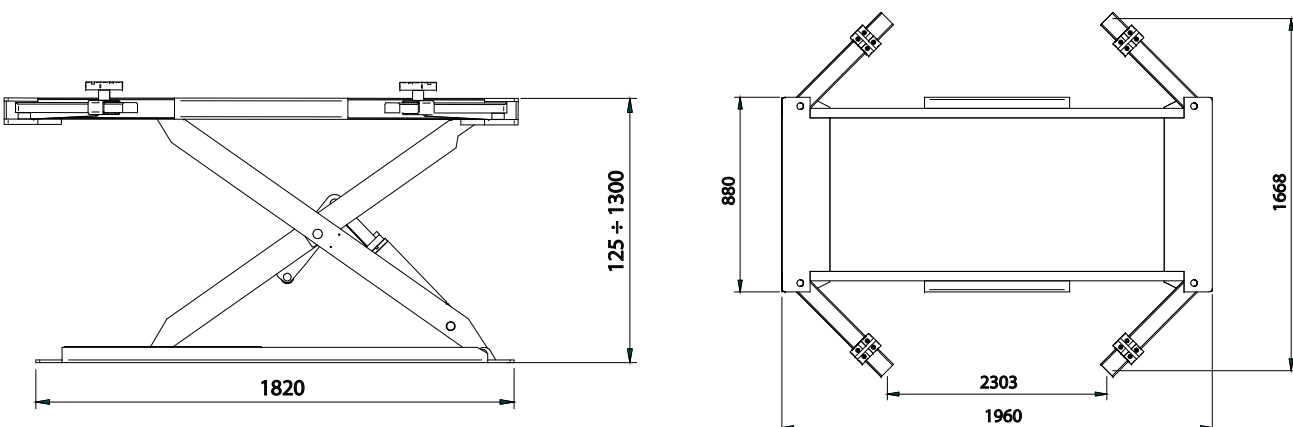

# PACKING SOLUTION

Lifts are packed firmly and securely to be world wide shipped, with a system that allows an easy and safe overlapping, thus saving on shipping costs. The quality of the outer coating ensures excellent protection against UV rays and, thanks to the type of materials used, the packaging is reduced and its recycling is made easier.

I ponti sollevatori sono imballati saldamente e in modo sicuro per essere spediti in tutto il mondo, con un sistema che consente una sovrapposizione facile e sicura risparmiando così sui costi di spedizione. La qualità del rivestimento esterno garantisce un'eccellente protezione dai raggi UV e, grazie al tipo di materiali utilizzati, l'imballaggio è ridotto e il suo riciclaggio è reso più semplice.

## BLUE LINE: WEIGHT AND MEASURES - PESI E MISURE

code codice	length cm. lunghezza cm.	depth cm. profondità cm.	height cm. altezza cm.	gross weight kg lordo kg	packing weight kg imballo kg	net weight kg netto kg
GT - V40	391	65	65	650	40	610
GT - V40 X	391	65	68	730	40	690
GT - V40 XL	391	65	68	750	40	710
GT - V40 M	391	65	65	650	40	600
GT - V40 MX	391	65	68	690	40	680
GT - V40 MXL	391	65	68	730	40	700
GT - EL 40	265	132	75	760	40	720
GT - EL 40 C	265	132	75	770	40	730
GT - EL 40 A	265	132	75	790	40	750
GT - EL 40 (CONTAINER)	270	101	50	760	40	730
GT - EL 40 (CONTAINER) Version C/A	270	101	50	760-790	40	720-750
GT - V80	400	85	76	2240	40	2200
GT - V80 X	400	85	120	2340	40	2300
GT - V80 XL	400	85	120	2440	40	2400
GT - V50	391	85	76	1040	40	1000
GT - V50 X	391	85	120	1100	40	1060
GT - V50 XL	391	85	120	1150	40	1110
GT - S400 A	500	70	120	2000	40	1960
GT - S400 ALT	500	70	120	2200	40	2160
GT - S400 F	500	70	120	1900	40	1840
GT - S400 FLT	500	70	120	2100	40	2060
GT - S400 FLT+HPD	500	70	120	2250	40	1920
GT - S400 SA	465	70	120	1950	40	1910
GT - S400 SALT	465	70	120	1900	40	1860
GT - S400 SF	465	70	120	1700	40	1660
GT - S400 SFLT	465	70	120	1800	40	1760
GT - S500 A	560	72	120	2200	40	1860
GT - S500 ALT	560	72	120	2300	40	2260
GT - S500 F	560	72	120	2100	40	2060
GT - S500 FLT	560	72	120	2200	40	2160
GT - S500 SA	500	72	120	2100	40	2060
GT - S500 SALT	500	72	120	2200	40	2160
GT - S500 SF	500	72	120	2000	40	1960
GT - S500 SFLT	500	72	120	2100	40	2060
GT - S600 A	560	72	120	2300	40	2260
GT - S600 ALT	560	72	120	2400	40	2360
GT - S600 F	560	72	120	2200	40	2160
GT - S600 FLT	560	72	120	2300	40	2260
GT - S600 SA	500	72	120	2200	40	2160
GT - S600 SALT	500	72	120	2300	40	2260
GT - S600 SF	500	72	120	2100	40	2060
GT - S600 SFLT	500	72	120	2200	40	2160



## GREY LINE: WEIGHT AND MEASURES - PESI E MISURE

code codice	length cm. lunghezza cm.	depth cm. profondità cm.	height cm. altezza cm.	gross weight kg lordo kg	packing weight kg imballo kg	net weight kg netto kg
GT - DS3.0DE	170	60	100	850	40	810
GT - DSH3.0 MASTER	160	65	60	880	40	840
GT - DSM3.0 MASTER	160	65	60	900	40	860
GT - DSH3.5 MASTER	160	65	60	900	40	860
GT - DSM3.5 MASTER	160	65	60	920	40	880
GT - DSH4.0 MASTER	160	65	60	1050	40	1010
GT - DSM4.0 MASTER	160	65	60	1070	40	1030
GT - MR3.0	150	55	65	650	40	610
GT - MR3.0 MOBILE	200	160	35	580	40	540
GT - BSL4.0A	460	70	120	2400	50	2350
GT - BSL5.5A	510	70	120	2600	50	2550
GT - BSULP4.0A	470	65	100	2300	50	2250
GT - BSULP5.5A	520	70	110	2500	50	2450
GT - BS4.0A	460	65	100	2400	50	2350
GT - BS5.5A	510	70	100	2900	50	2850
GT - BSLP3.5A	430	70	100	2500	50	2450
GT - BSLP5.5A	510	70	100	2600	50	2550
GT - FPF3.5	460	60	100	1200	50	1150
GT - FPF4.5	540	60	100	1350	50	1300
GT - FPF5.5	540	60	100	1450	50	1400
GT - FPA3.5	460	60	110	1700	50	1650
GT - FPA4.5	540	60	110	1500	50	1450
GT - FPA5.5	540	60	110	1750	50	1700
GT - TPF4.0AIR	300	50	100	700	30	670
GT - TPF4.0AIR2	300	50	100	720	30	690
GT - TPB4.0BASEMENT	300	50	100	950	30	920
GT - TPB4.0BASEMENT2	300	50	100	970	30	940
GT - TP4.0TOP	400	55	100	830	30	800
GT - TP4.0TOP2	400	55	100	850	30	820
GT - RJ2P	100	50	40	140	20	120
GT - RJ3P	100	50	40	165	20	145
GT - RJ2M	100	50	40	140	20	120
GT - MJ	125	72	42	160	30	130
GT - BATTERY LIFT	200	45	50	600	40	560
GT - MC 600	220	80	40	220	20	200
GT - 3.0 SB	240	800	90	640	40	600
GT - 3.0 SBS	200	90	90	580	40	540



# DEALERS WORLDS MAP





***LIFT IT TO BELIEVE IT !!!***



# GALTA

Vat. n° 04058700248

Via Vittorio Lombardi 19/21 - 36075 Montecchio Maggiore (VI) Italy

Phone : +39 0444 493977 - Fax: +39 0444 495999

[www.galta.it](http://www.galta.it) - [info@galta.it](mailto:info@galta.it)

