



www.es-toolbox.com



GALTA



GREY LINE
BIG SCISSOR



GT-BS GT-BSL GT-BSLP GT-BSULP

VEHICLE LIFTS



ITALIAN PREMIUM QUALITY

GT - BS 3.5 - 4.0 - 4.5 - 5.5



Electrohydraulic scissor lift with double manual alignment and anti-knock valve - Lifting height: 330 - 2160 mm - pneumatic release with safety lock - version 5.5T with double cylinder - standard engine power 2,2/3,0 KW - 400V/3PH/50HZ - Required pneumatic connection for safe release 6/8 bar (VERSION ON FLOOR OR RECESSED VERSION)

Sollevatore a forbice elettro-idraulico con doppio allineamento e valvola paracadute - altezza di sollevamento 330 - 2160 mm - sicure a sgancio pneumatico - versione 5.5T con doppio cilindro - potenza motore 2.2/3.0KW - 400V/3PH/50HZ - Richiesta connessione pneumatica per lo sgancio delle sicure 6/8 bar (VERSIONE A INCASSO O A PAVIMENTO)

MODEL	PLATFORM (mm)	LIFT CAPACITY	LT CAPACITY	DESCRIPTION
GT-BS 3.5 F ONLY ON REQUEST	4000 x 610	3.5 T	3.5 T	Flat platform - safety lock with pneumatic release - power 2.2Kw - 400v/50hz/3ph Pedana piana - sicura con sgancio pneumatico - potenza motore 2.2Kw - 400v/50hz/3ph
GT-BS 3.5 A	4000 x 610	3.5 T	3.5 T	Lift Table with lifting height of 450mm - lifting capacity 3500Kg - front recess length 780mm - sliding plates 1384mm - safety lock with pneumatic release - engine power 2.2Kw - 400v/50hz/3ph Lift table con altezza sollevamento 450mm portata 3500kg - incavo anteriore lunghezza 780mm - piani oscillanti 1384mm - sicura con sgancio pneumatico - potenza motore 2.2Kw - 400v/50hz/3ph
GT-BS 4.0 F ONLY ON REQUEST	4500 x 610	4.0 T	4.0 T	Flat platform - safety lock with pneumatic release - engine power 2.2Kw - 400v/50hz/3ph Pedana piana - sicura con sgancio pneumatico - potenza motore 2.2Kw - 400v/50hz/3ph
GT-BS 4.0 A	4500 x 610	4.0 T	4.0 T	Lift Table with lifting height of 450mm - lifting capacity 4000Kg - front recess length 980mm - sliding plates 1684mm - safety lock with pneumatic release - engine power 2.2Kw - 400v/50hz/3ph Lift table con altezza sollevamento 450mm - incavo anteriore lunghezza 980mm - piani oscillanti 1684mm - sicura con sgancio pneumatico - potenza motore 2.2Kw - 400v/50hz/3ph
GT-BS 4.5 F ONLY ON REQUEST	5030 x 620	4.5 T	4.5 T	Flat platform - safety lock with pneumatic release - double cylinder - engine power 2.2Kw - 400v/50hz/3ph Pedana piana - sicura con sgancio pneumatico - doppio cilindro - potenza motore 2.2Kw - 400v/50hz/3ph
GT-BS 4.5 A	5030 x 620	4.5 T	4.5 T	Lift Table with lifting height of 450mm - lifting capacity 4500Kg - front recess length 1170mm - sliding plates 1784mm - safety lock with pneumatic release - double cylinder - engine power 2.2Kw - 400v/50hz/3ph Lift table con altezza sollevamento 450mm - incavo anteriore lunghezza 1170mm - piani oscillanti 1784mm - sicura con sgancio pneumatico - doppio cilindro - potenza motore 2.2Kw - 400v/50hz/3ph
GT-BS 5.5 F ONLY ON REQUEST	5030 x 620	5.5 T	5.5 T	Flat platform - safety lock with pneumatic release - double cylinder - engine power 3.0Kw - 400v/50hz/3ph Pedana piana - sicura con sgancio pneumatico - doppio cilindro - potenza motore 3.0Kw - 400v/50hz/3ph
GT-BS 5.5 A	5030 x 620	5.5 T	5.5 T	Lift Table with lifting height of 450mm - front recess length 1170mm - sliding plates 1784mm - safety lock with pneumatic release - double cylinder - engine power 3.0Kw - 400v/50hz/3ph Lift table con altezza sollevamento 450mm - incavo anteriore lunghezza 1170mm - piani oscillanti 1784mm - sicura con sgancio pneumatico - doppio cilindro - potenza motore 3.0Kw - 400v/50hz/3ph

ON REQUEST: ROLLING JACK RAILS
A RICHIESTA: CORSIE ROLLING JACK

OPTIONAL

- Play Detector 6 Movements
Prova-giochi 6 movimenti
- Emergency Manual Descent Pump
Pompa di emergenza manuale
- Kit LED lamp
Kit lampade a led
- Approaching ramps set for on floor installation
Set rampe salita per installazione a pavimento
- Expansion bolt set (12pcs)
Tasselli ad espansione (12pcs)
- Pipe kit to change hydraulic unit from RH to LH side
Kit tubi per centralina da lato destro a sinistro
- Hydraulic/electrical hoses extension 1 mt
Kit tubi idraulici/cavi elettrici + 1 mt
- Hydraulic/electrical hoses extension 2 mt
Kit tubi idraulici/cavi elettrici + 2 mt
- Hydraulic/electrical hoses extension 3 mt
Kit tubi idraulici/cavi elettrici + 3 mt
- Turning plates set for alignment + cover
Piatti rotanti per allineamento + coperture
- Complete covers front recess (3pcs)
Coperture complete per incavo anteriore (3pcs)
- Complete covers front recess (2pcs)
Coperture complete per incavo anteriore (2pcs)

STANDARD LIFT TABLE
TORRETTA STANDARD



All models are provided with 4 rubber.

ALL OUR PRODUCT ARE SUPPLIED WITH SANDBLASTING. STANDARD COLOURS: GREY RAL 7016 - GREY RAL 7040

Tutti i modelli vengono forniti con 4 tamponi in gomma.

SU TUTTI I PONTI VIENE APPLICATO IL TRATTAMENTO DI SABBIAIATURA. COLORI STANDARD: GRIGIO RAL 7016 - GRIGIO RAL 7040

GT - BS 3.5 - 4.0

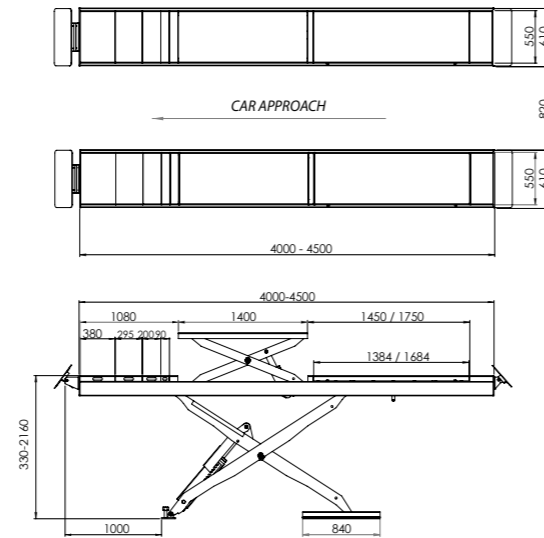
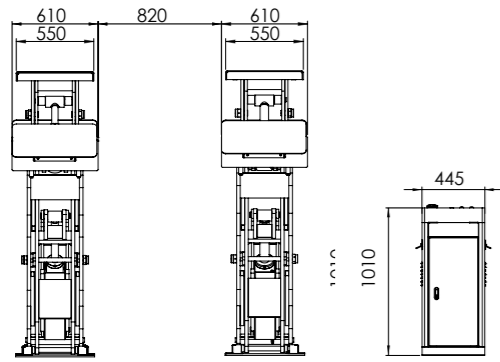

GT - BS 4.5

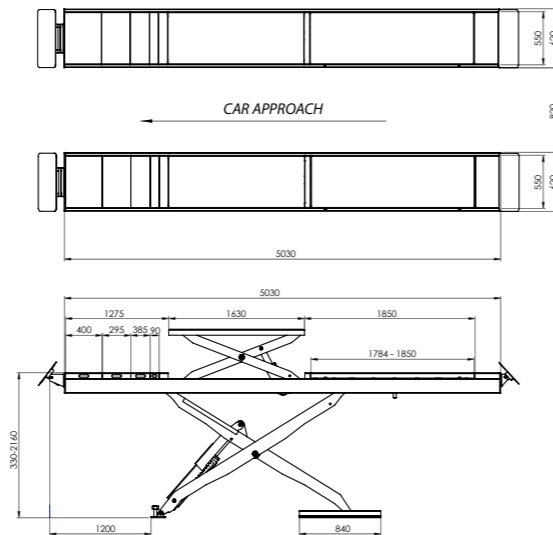
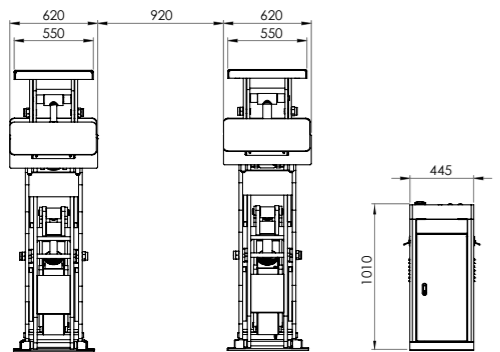

GT - BS 5.5

**DOPPIO CILINDRO
DOUBLE CYLINDER**

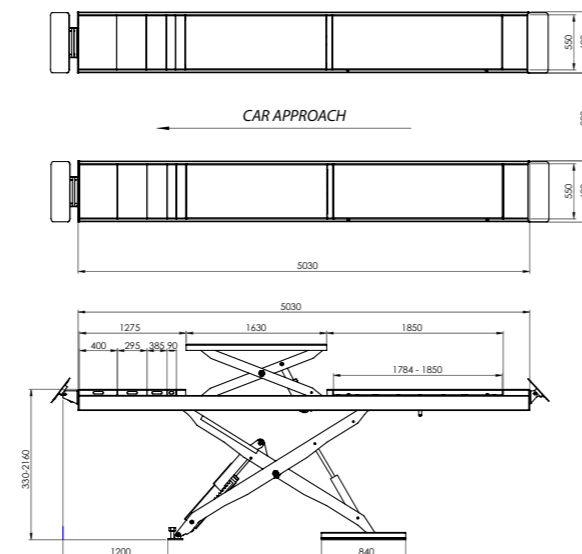
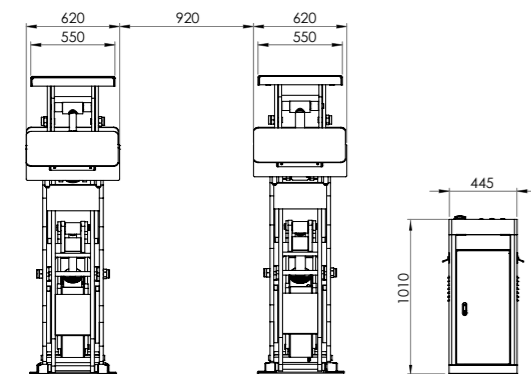

GT - BS

- 1** CONTROL UNIT WITH TRIPLE OPENING
CENTRALINA CON TRIPLA APERTURA
- 2** STANDARD LIFT TABLE
LIFT TABLE
- 3** SLADING PLATES
PIANI OSCILLANTI
- 4** CYLINDER WITH MECHANICAL SAFETY RELEASE
SICURA MECCANICA SUI CILINDRI



3.500 Kg

4.000 Kg

4.500 Kg

5.500 Kg



GT - BSL 3.5 - 4.0 - 4.5



GT - BSL 5.5 **DOPPIO CILINDRO** **DOUBLE CYLINDER**

Electrohydraulic scissor lift with double alignment - pneumatic release - safety lock - antiknock valve - Lifting Height 330-2160mm - standard engine power 2,2/3,0 KW/400V/3PH/50HZ
Required pneumatic connection for safe release 6/8 bar. (ON FLOOR OR RECESSED VERSION)

Sollevatore a forbice elettro-idraulico con doppio allineamento - sgancio sicura pneumatico - valvola paracadute e con altezza di sollevamento di 330-2160mm - potenza motore 2,2/3,0KW/400V/3PH/50HZ - richiesta connessione pneumatica per lo sgancio delle sicure 6/ bar. (VERSIONE A INCASSO O A PAVIMENTO)

MODEL	PLATFORM (mm)	LIFT CAPACITY	DESCRIPTION
GT-BSL 3.5 F ON REQUEST	4000 x 654	3.5 T	Flat platform - safety lock with pneumatic release - 2.2Kw - 400v/50hz/3ph Pedana piana - sicura con sgancio pneumatico - 2.2Kw - 400v/50hz/3ph
GT-BSL 3.5 A	4000 x 654	3.5 T	front recess lenght 770mm - sliding plates 1384mm - safety lock with pneumatic release - engine power 2.2Kw - 400v/50hz/3ph Incavo anteriore lunghezza 770mm - piani oscillanti 1384mm - sicura con sgancio pneumatico - 2.2Kw - 400v/50hz/3ph
GT-BSL 4.0 F ON REQUEST	4500 x 654	4.0 T	Flat platform - safety lock with pneumatic release - engine power 2.2Kw - 400v/50hz/3ph Pedana piana - sicura con sgancio pneumatico - 2.2Kw - 400v/50hz/3ph
GT-BSL 4.0 A	4500 x 654	4.0 T	Front recess lenght 990mm - sliding plates 1684mm - safety lock with pneumatic release - engine power 2.2Kw - 400v/50hz/3ph Incavo anteriore lunghezza 990mm - piani oscillanti 1684mm - sicura con sgancio pneumatico - 2.2Kw - 400v/50hz/3ph
GT-BSL 4.5 F ON REQUEST	5030 x 667	4.5 T	Flat platform - safety lock with pneumatic release - engine power 2.2Kw - 400v/50hz/3ph Pedana piana - sicura con sgancio pneumatico - 2.2Kw - 400v/50hz/3ph
GT-BSL 4.5 A	5030 x 667	4.5 T	front recess lenght 1180mm - sliding plates 1784mm - safety lock with pneumatic release - engine power 2.2Kw - 400v/50hz/3ph Incavo anteriore lunghezza 1180mm - piani oscillanti 1784mm - sicura con sgancio pneumatico - 2.2Kw - 400v/50hz/3ph
GT-BSL 5.5 F ON REQUEST	5030 x 667	5.5 T	Flat platform - safety lock with pneumatic release - double cylinder - engine power 3.0Kw - 400v/50hz/3ph Pedana piana - sicura con sgancio pneumatico - doppio cilindro - 3,0Kw - 400v/50hz/3ph
GT-BSL 5.5 A	5030 x 667	5.5 T	front recess lenght 1180mm - sliding plates 1784mm - safety lock with pneumatic release - double cylinder - engine power 3.0Kw - 400v/50hz/3ph Incavo anteriore lunghezza 1180mm - piani oscillanti 1784mm - sicura con sgancio pneumatico - doppio cilindro - 3,0Kw - 400v/50hz/3ph

STANDARD ROLLING JACK RAILS STANDARD CORSIE ROLLING JACK

On request all platforms can be provided with sliding plates, turning plates and rolling jack. All our product are supplied with sandblasting.
STANDARD COLOURS: GREY RAL 7016 - GREY RAL 7040

A richiesta tutte le pedane possono ospitare piani oscillanti, piatti rotanti e rolling jack.
Su tutti i ponti viene applicato il trattamento di sabbatura
COLORI STANDARD: GRIGIO RAL 7016 - GRIGIO RAL 7040

OPTIONAL

- Play Detector 6 Mov
Prova-giochi 6 movimenti
- Emergency Manual Descent Pump
Pompa di emergenza manuale
- Kit LED lamp
Kit lampade a led
- Approaching ramps set for on floor installation
Set rampe salita per installazione a pavimento
- Expansion bolt set (12pcs)
Tasselli ad espansione (12pcs)
- Rubber pads
Tamponi in gomma
- Pipe kit to change hydraulic unit from RH to LH side
Kit tubi per centralina da lato destro a sinistro
- Hydraulic/electrical hoses extension 1 mt
Kit tubi idraulici/cavi elettrici + 1 mt
- Hydraulic/electrical hoses extension 2 mt
Kit tubi idraulici/cavi elettrici + 2 mt
- Hydraulic/electrical hoses extension 3 mt
Kit tubi idraulici/cavi elettrici + 3 mt
- Turning plates set for alignment + cover
Piatti rotanti per allineamento + coperture
- Complete covers front recess (3pcs)
Coperture complete per incavo anteriore (3pcs)
- Rolling jack 2T manual
Rolling jack 2T manuale
- Rolling jack 2T pneumatic
Rolling jack 2T pneumatico
- Rolling jack 3T pneumatic
Rolling jack 3T pneumatico

NOTE



CONTROL BOX
CENTRALINA DI COMANDO



ALIGNMENT LIFT
PONTE PER ASSETTI

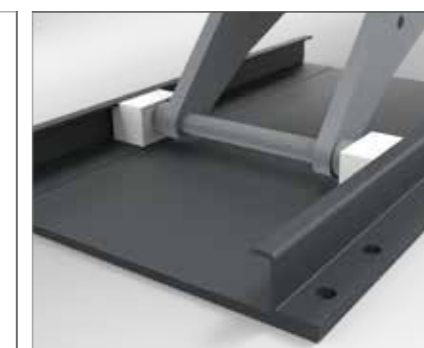

SLIDING PAD
PATTINI DI SCORRIMENTO

GT - BSL 3.5

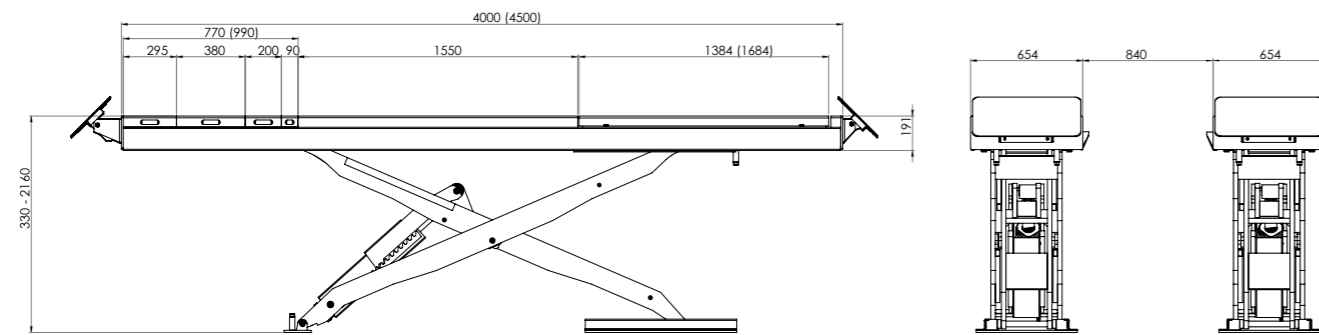

GT - BSL 4.5

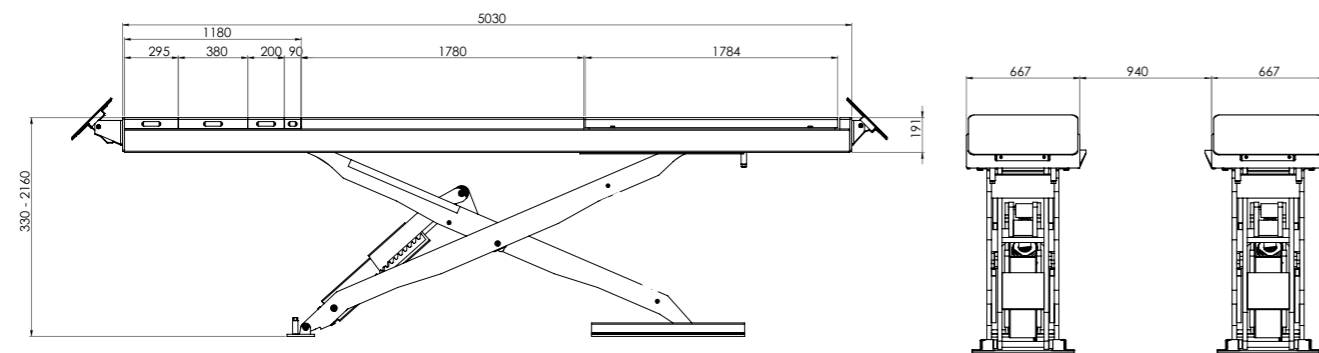

GT - BSL 5.5

**DOPPIO CILINDRO
DOUBLE CYLINDER**

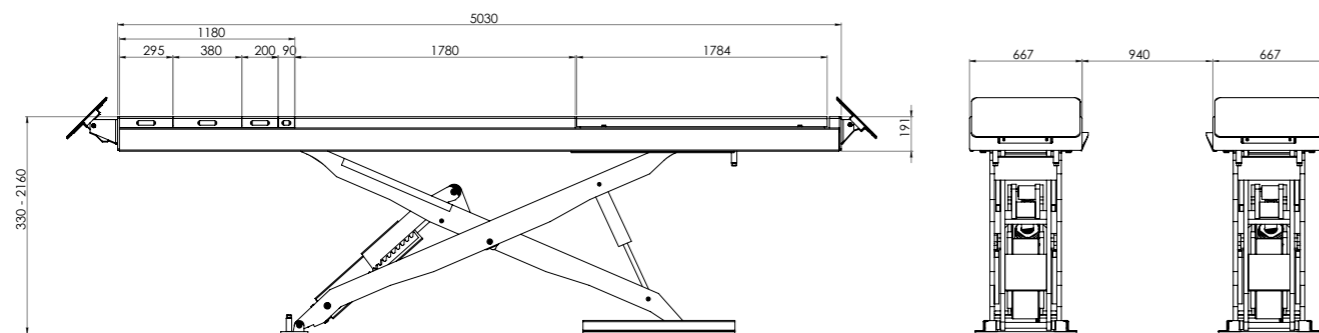

GT - BSL

- 1** MOBILE COVERS
COPERTURE MOBILI
- 2** FIXED COVER or SLIDING PLATES
COPERTURA FISSA o PIANO OSCILLANTE
- 3** CYLINDER WITH MECHANICAL SAFETY LOCK
SICURA MECCANICA SUI CILINDRI

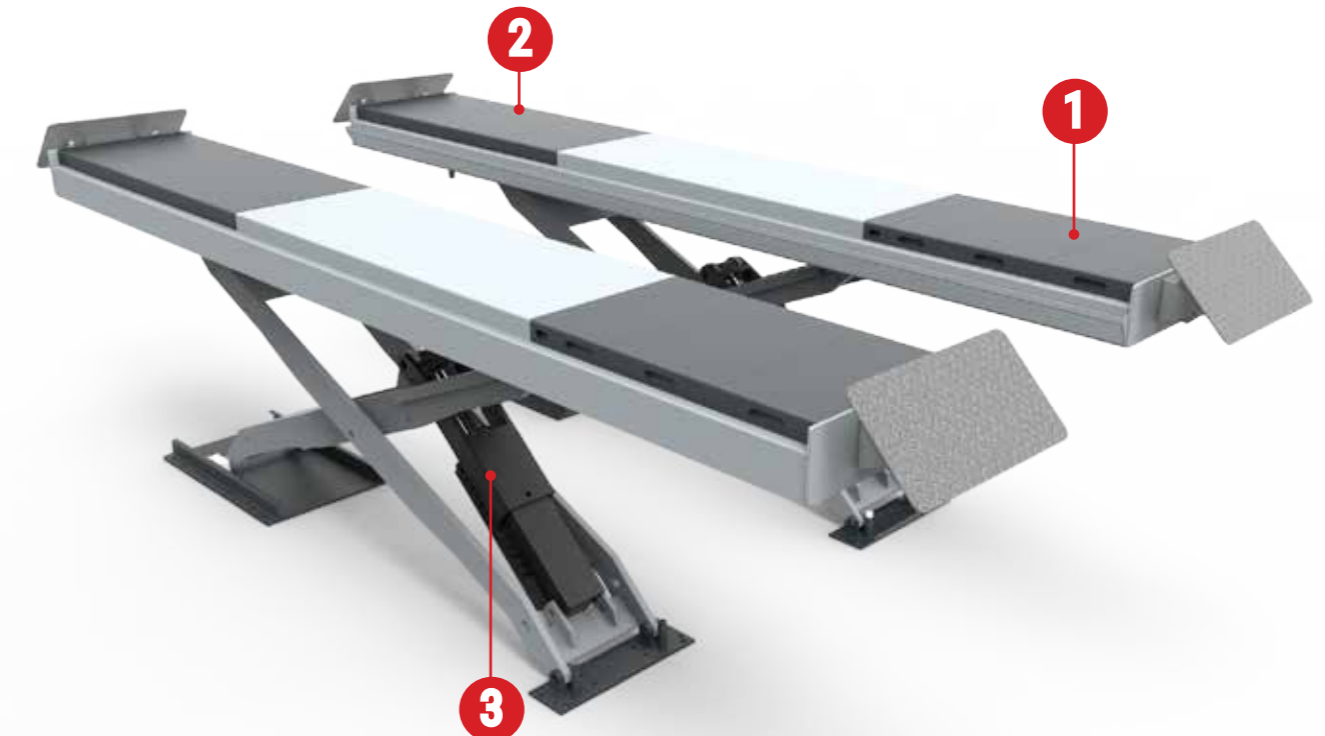

3.500 Kg

4.000 Kg

4.500 Kg

5.500 Kg

GT - BSLP 3.5 - 4.5 - 5.5



Low profile electrohydraulic scissor lift - antiknock valve - lifting height: 220-1880mm - pneumatic release with safety lock - 3 cylinders per platform - Standard engine power 3,0 KW/400V/3PH/50HZ - Required pneumatic connection for safe release 6/8 bar. (VERSION ON FLOOR)

Sollevatore a forbice elettro-idraulico per assetto a basso profilo - valvola paracadute - altezza di sollevamento 220 - 1880mm - sicure a sgancio pneumatico - 3 cilindri per pedana - potenza motore 3.0KW - 400V/3PH/50HZ - Richiesta connessione pneumatica per lo sgancio delle sicure 6/8 bar. (VERSIONE A PAVIMENTO)

MODEL	PLATFORM (mm)	LIFT CAPACITY	LT CAPACITY	DESCRIPTION
GT-BSLP 3.5 F ONLY ON REQUEST	4200 x 680	3.5 T	3.5 T	Flat platform - safety lock with pneumatic release - 2 front cylinders - 1 rear cylinder - Lift table with mechanical safety lock - engine power 3.0Kw - 400v/50hz/3ph Pedana piana - Lift table con altezza sollevamento 450mm - sicura con sgancio pneumatico - 2 cilindri anteriori - 1 cilindro posteriore 3.0Kw - 400v/50hz/3ph
GT-BSLP 3.5 A	4200 x 680	3.5 T	3.5 T	Lift Table with lifting height of 450mm - lifting capacity 3500Kg - front recess length 970mm (4200X680) - sliding plates 1320mm (4200X680) - movable rear cover - safety lock with pneumatic release - 2 front cylinders - 1 rear cylinder - lift table with mechanical safety lock - engine power 3.0Kw - 400v/50hz/3ph Lift table con altezza sollevamento 450mm - incavo anteriore lunghezza 970mm (4200X680) - piani oscillanti 1320mm (4200 x 680) - sicura con sgancio pneumatico - 2 cilindri anteriori - 1 cilindro posteriore sicura meccanica della torretta 3.0Kw - 400v/50hz/3ph
GT-BSLP 4.5 F ONLY ON REQUEST	4600 x 704	4.5 T	4.5 T	Flat platform - safety lock with pneumatic release - 2 front cylinders - 1 rear cylinder - Lift table with mechanical safety lock - engine power 3.0Kw - 400v/50hz/3ph Pedana piana - Lift table con altezza sollevamento 450mm - sicura con sgancio pneumatico - 2 cilindri anteriori - 1 cilindro posteriore 3.0Kw - 400v/50hz/3ph
GT-BSLP 4.5 A	4600 x 704	4.5 T	4.5 T	Lift Table with lifting height of 450mm - lifting capacity 4500Kg - front recess length 1170 (4600X704) - sliding plates 1520mm (4600x704) - movable rear cover - safety lock with pneumatic release - 2 front cylinders - 1 rear cylinder - Lift table with mechanical safety lock - engine power 3.0Kw - 400v/50hz/3ph Lift table con altezza sollevamento 450mm portata 4500kg - incavo anteriore lunghezza - 1170 (4600 X 704) - piani oscillanti 1520mm (4600 x 704) - sicura con sgancio pneumatico - 2 cilindri anteriori - 1 cilindro posteriore sicura meccanica della torretta 3.0Kw - 400v/50hz/3ph
GT-BSLP 5.5 F ONLY ON REQUEST	5030 x 704	5.5 T	5.5 T	Flat platform - safety lock with pneumatic release - 2 front cylinders - 1 rear cylinder - Lift Table with mechanical safety lock - engine power 3.0Kw - 400v/50hz/3ph Pedana piana - Lift table con altezza sollevamento 450mm - sicura con sgancio pneumatico - 2 cilindri anteriori - 1 cilindro posteriore 3.0Kw - 400v/50hz/3ph
GT-BSLP 5.5 A	5030 x 704	5.5 T	5.5 T	Lift Table with lifting height of 450mm - lifting capacity 5500Kg - front recess length 1270 (5030x704) - sliding plates 1850mm (5030X704) - movable rear cover - safety lock with pneumatic release - 2 front cylinders - 1 rear cylinder - Lift Table with mechanical safety lock - engine power 3.0Kw - 400v/50hz/3ph Lift table con altezza sollevamento 450mm portata 5500kg -incavo anteriore lunghezza 1270 (5030 X 704) - piani oscillanti - 1850mm (5030 x 704) - sicura con sgancio pneumatico- 2 cilindri anteriori - 1 cilindro posteriore sicura meccanica della torretta 3.0Kw - 400v/50hz/3ph

ONLY ON REQUEST: ROLLING JACK RAILS
SOLO A RICHIESTA CORSIE ROLLING JACK

OPTIONAL

- Play Detector 6 Mov
Prova-giochi 6 movimenti
- Emergency Manual Descent Pump
Pompa di emergenza manuale
- Kit LED lamp
Kit lampade a led
- Approaching ramps set for on floor installation
Set rampe salita per installazione a pavimento
- Expansion bolt set (12pcs)
Tasselli ad espansione (12pcs)
- Lift Table with 1 extension
Lift Table con 1 estensione
- Lift Table with 2 extensions
Lift Table con 2 estensione
- Rubber pads
Tamponi in gomma
- Pipe kit for moving hydraulic unit from RH to LH side
Kit tubi per centralina da lato destro a sinistro
- Hydraulic/electrical hoses extension 1 mt
Kit tubi idraulici/cavi elettrici + 1 mt
- Hydraulic/electrical hoses extension 2 mt
Kit tubi idraulici/cavi elettrici + 2 mt
- Hydraulic/electrical hoses extension 3 mt
Kit tubi idraulici/cavi elettrici + 3 mt
- Turning plates set for alignment + cover
Piatti rotanti per allineamento + coperture
- Complete covers front recess (3pcs)
Coperture complete per incavo anteriore (3pcs)
- Complete covers front recess (2pcs)
Coperture complete per incavo anteriore (2pcs)
- Rolling jack 2T manual
Rolling jack 2T manuale
- Rolling jack 2T pneumatic
Rolling jack 2T pneumatico
- Rolling jack 3T pneumatic
Rolling jack 3T pneumatico

NOTE



3 CYLINDER PER PLATFORM
TRE CILINDRI PER PEDANA

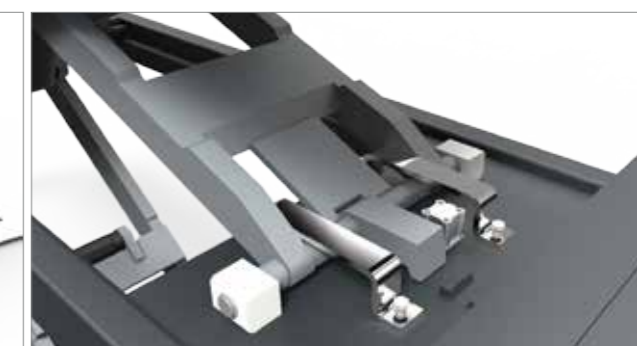

MECHANICAL SAFETY LOCK
SICURA MECCANICA

All models are provided with 4 rubber On request all platforms can be provided with sliding plates - turning plates - HPD - lift table with 1 extension - lift table with 2 extensions. All our product are supplied with sandblasting.
STANDARD COLOURS: GREY RAL 7016 - GREY RAL 7040

Tutti i modelli vengono forniti con 4 tamponi in gomma. A richiesta tutte le pedane possono ospitare piani oscillanti, piatti rotanti - torretta con 1 estensione - torretta con 2 estensioni. Su tutti i ponti viene applicato il trattamento di sabbiatura.
COLORI STANDARD: GRIGIO RAL 7016 - GRIGIO RAL 7040

GT - BSLP 3.5 - 4.5 - 5.5

GT - BSLP



LIFT TABLE WITH 1 EXTENSION
LIFT TABLE CON 1 ESTENSIONE



ROLLING JACK 2T / 3 T
ROLLING JACK 2T / 3T



LIFT TABLE WITH 2 EXTENSION
LIFT TABLE CON 2 ESTENSIONE



STANDARD LIFT TABLE
LIFT TABLE STANDARD

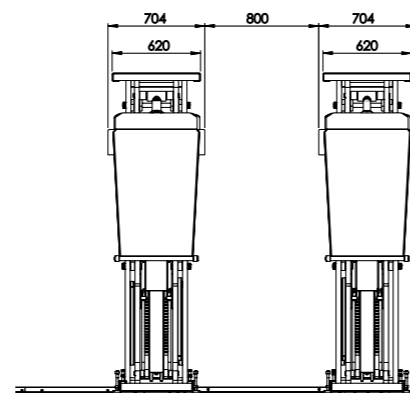
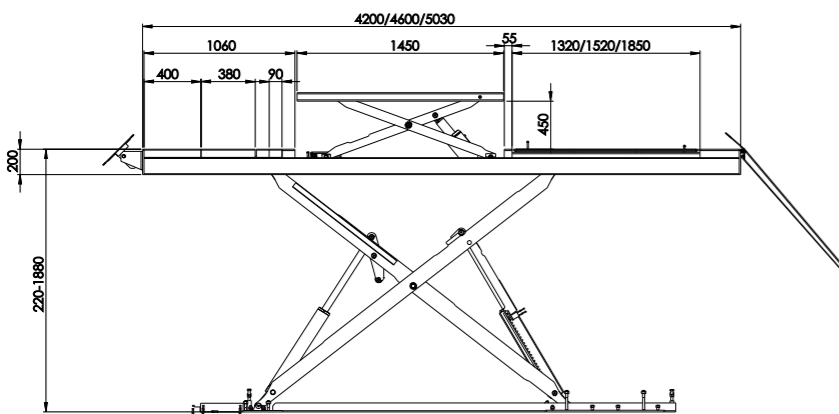

3.500 Kg

4.500 Kg

5.500 Kg

- 1** MOBILE COVERS
COPERTURE MOBILI
- 2** STANDARD LIFT TABLE
LIFT TABLE
- 3** APPROACHING RAMPS
RAMPE SALITA
- 4** SLADING PLATES
PIANI OSCILLANTI
- 5** ASSISTANT CYLINDER WITH MECHANICAL SAFETY LOCK
CILINDRO DI ASSISTENZA CON SICURA MECCANICA
- 6** DOUBLE CYLINDER MASTER/SLAVE
DOPPIO CILINDRO MASTER/SLAVE
- 7** LIFT TABLE WITH MECHANICAL SAFETY LOCK WITH PNEUMATIC RELEASE
LIFT TABLE CON SICURA MECCANICA A SGANCIO PNEUMATICO

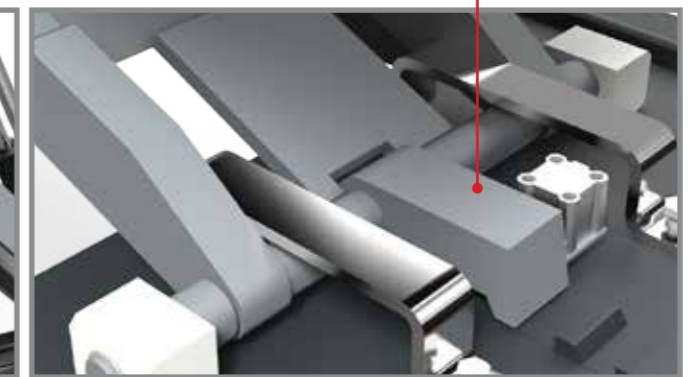
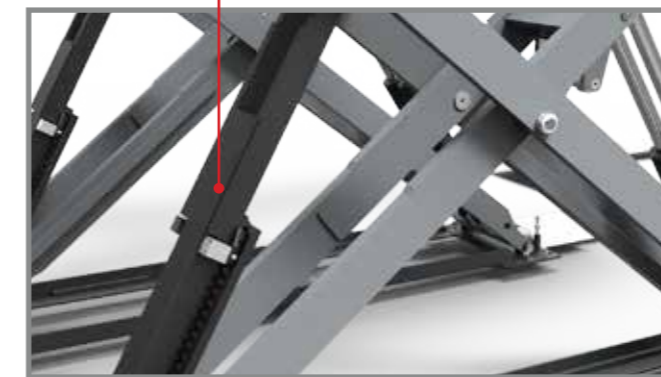

GT - BSULP 3.5 - 4.0 - 4.5 - 5.5



Ultra low profile electrohydraulic scissor lift (built-in recess) with double alignment and anti-knock valve - Lifting Height 200-1860mm - safety lock with pneumatic release - double cylinder - standard engine power 2.2/3.0 KW - 400V/3PH/50 HZ - on request 2,2 KW/220 V/1PH/50HZ - Required pneumatic connection for safe release 6/8 bar. (VERSION ON FLOOR OR RECESSED)

Sollevatore a forbice elettro-idraulico ribassato (incavi incassati) con doppio allineamento e valvola paracadute - altezza di sollevamento 200 - 1860mm - sicure a sgancio pneumatico - doppio cilindro - potenza motore 2.2/3.0KW - 400V/3PH - Richiede connessione pneumatica per lo sgancio delle sicure 6/8 bar (VERSIONE A PAVIMENTO O A INCASSO)

MODEL	PLATFORM (mm)	CAPACITY	DESCRIPTION
GT-BSULP 3.5 F ON REQUEST	4000 x 635	3.5 T	Flat platform - pneumatic release with safety lock 2.2Kw - 400v/50hz/3ph Pedana piana ribassata - coperture incavo posteriore fissa - sicura con sgancio pneumatico - 2.2Kw - 400v/50hz/3ph
GT-BSULP 3.5 A	4000 x 635	3.5 T	Platform with front recess length 775mm - sliding plates 1400mm - pneumatic release with safety lock - 2.2Kw - 400v/50hz/3ph Pedana ribassata con incavo anteriore lunghezza 775mm - piani oscillanti 1400mm - sicura con sgancio pneumatico - piano oscillante - 2.2Kw - 400v/50hz/3ph
GT-BSULP 4.0 F ON REQUEST	4500 x 635	4.0 T	Flat platform - pneumatic release safety lock - 2.2Kw - 400v/50hz/3ph Pedana piana ribassata - coperture incavo posteriore fissa - sicura con sgancio pneumatico - 2.2Kw - 400v/50hz/3ph
GT-BSULP 4.0 A	4500 x 635	4.0 T	Platform with front recess length 900mm - sliding plates 1450mm - pneumatic release safety lock - 2.2Kw - 400v/50hz/3ph Pedana ribassata con incavo anteriore lunghezza 900mm - piani oscillanti 1450mm - sicura con sgancio pneumatico - piano oscillante - 2.2Kw - 400v/50hz/3ph
GT-BSULP 4.5 F ON REQUEST	5030 x 635	4.5 T	Flat platform - pneumatic release safety lock - 2.2Kw - 400v/50hz/3ph Pedana piana ribassata - coperture incavo posteriore fissa - sicura con sgancio pneumatico - 2.2Kw - 400v/50hz/3ph
GT-BSULP 4.5 A	5030 x 635	4.5 T	Platform with front recess length 1100mm - sliding plates 1900mm - pneumatic release safety lock - 2.2Kw - 400v/50hz/3ph Pedana ribassata con incavo anteriore lunghezza 1100mm - piani oscillanti 1900mm - sicura con sgancio pneumatico - piano oscillante - 2.2Kw - 400v/50hz/3ph
GT-BSULP 5.5 F ON REQUEST	5030 x 635	5.5 T	Flat platform - safety lock with pneumatic release - double cylinder - engine power 3.0Kw - 400v/50hz/3ph Pedana piana ribassata - coperture incavo posteriore fissa - sicura con sgancio pneumatico - potenza motore 3.0Kw - 400v/50hz/3ph
GT-BSULP 5.5 A	5030 x 635	5.5 T	Lift Table with lifting height of 450mm - lifting capacity 5500Kg - front recess length 1100mm - sliding plates 1900 mm - safety lock with pneumatic release - double cylinder - engine power 3.0Kw - 400v/50hz/3ph Pedana ribassata con incavo anteriore lunghezza 1100mm - piani oscillanti 1900mm - sicura con sgancio pneumatico - piano oscillante - potenza motore 3.0Kw - 400v/50hz/3ph

STANDARD: ROLLING JACK RAILS
STANDARD: CORSIE ROLLING JACK

OPTIONAL

- Play Detector 6 MOVEMENTS
Prova-giochi 6 movimenti
- Emergency Manual Descent Pump
Pompa di emergenza manuale
- Kit LED lamp
Kit lampade a led
- Approaching ramps set for on floor installation
Set rampe salita per installazione a pavimento
- Expansion bolt set (12pcs)
Tasselli ad espansione (12pcs)
- Lift Table with 1 extension
Lift Table con 1 estensione
- Lift Table with 2 extensions
Lift Table con 2 estensione
- Rubber pads
Tamponi in gomma
- Pipe kit to change hydraulic unit from RH to LH side
Kit tubi per centralina da lato destro a sinistro
- Hydraulic/electrical hoses extension 1 mt
Kit tubi idraulici/cavi elettrici + 1 mt
- Hydraulic/electrical hoses extension 2 mt
Kit tubi idraulici/cavi elettrici + 2 mt
- Hydraulic/electrical hoses extension 3 mt
Kit tubi idraulici/cavi elettrici + 3 mt
- Turning plates set for alignment + cover
Piatti rotanti per allineamento + coperture
- Complete covers front recess (3pcs)
Coperture complete per incavo anteriore (3pcs)
- Complete covers front recess (2pcs)
Coperture complete per incavo anteriore (2pcs)
- Rolling jack 2T manual
Rolling jack 2T manuale
- Rolling jack 2T pneumatic
Rolling jack 2T pneumatico
- Rolling jack 3T pneumatic
Rolling jack 3T pneumatico



SLADING PLATES
PATTINI DI SCORRIMENTO

On request all platforms can be provided with sliding plates, turning plates and rolling jack.
All our product are supplied with sandblasting. STANDARD COLOURS: GREY RAL 7016 - GREY RAL 7040

A richiesta tutte le pedane possono ospitare piani oscillanti, piatti rotanti e rolling jack.
Su tutti i ponti viene applicato il trattamento di sabbiatura..COLORI STANDARD: GRIGIO RAL 7016 - GRIGIO RAL 7040

GT - BSULP

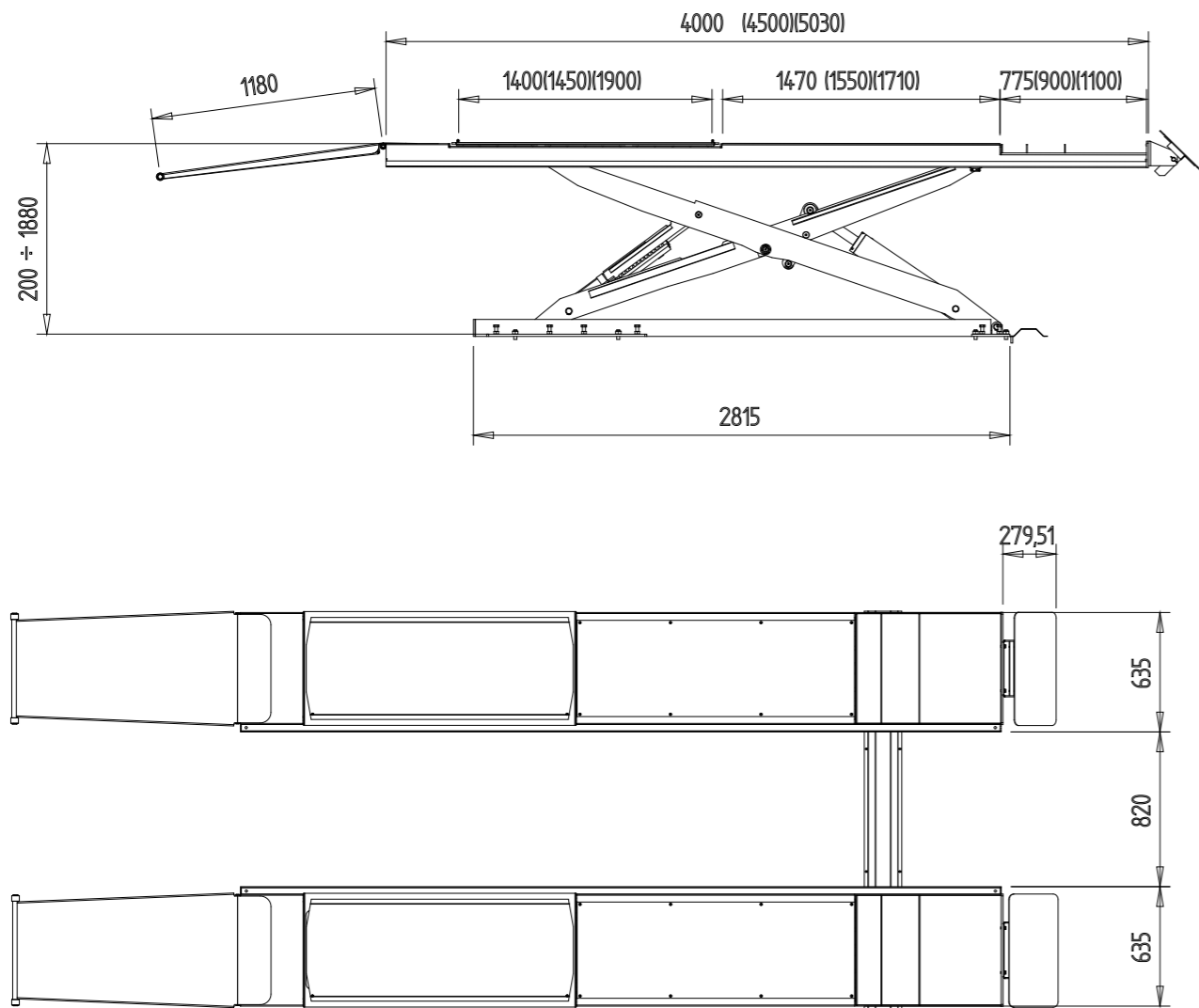

GT - BSULP

- 1** MOBILE COVERS
COPERTURE MOBILI
- 2** APPROACHING RAMPS
RAMPE SALITA
- 3** SLADING PLATES
PIANI OSCILLANTI
- 4** FRONT CYLINDER
CILINDRO ANTERIORE
- 5** REAR CYLINDER WITH MECHANICAL SAFETY LOCK
CILINDRO POSTERIORE CON SICURA MECCANICA

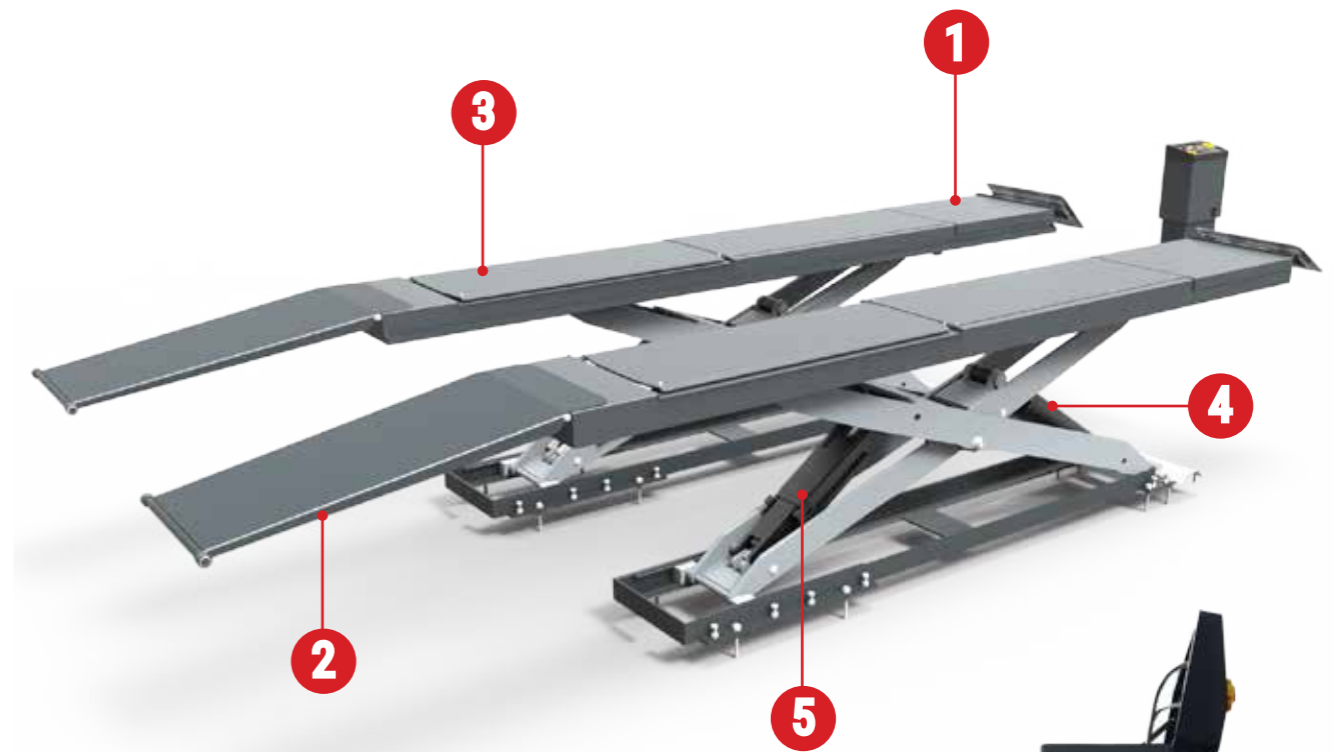

CONTROL UNIT WITH TRIPLE ACCESS
CENTRALINA CON TRIPLO - ACCESSO



- 3.500 Kg**
- 4.000 Kg**
- 4.500 Kg**
- 5.500 Kg**



GALTA

Vat. n° 04058700248

Via Vittorio Lombardi 19/21 36075 - Montecchio Maggiore (VI) Italy

Phone : +39 0444 493977 - Fax: +39 0444 495999

www.galta.it

info@galta.it