



www.es-toolbox.com



GALTA



BLUE LINE 2 POST LIFTS

GT-EL40



VEHICLE LIFTS



ITALIAN PREMIUM QUALITY

GT - EL 40



Two post electro-mechanical lift - with air or floor connection - mechanical drive - 2 independent electronically synchronized engines - double safety nut and breakage microswitch - asymmetrical columns - motor power 2 x 3,6 kw-400V/3PH 50Hz

Sollevatore elettromeccanico 2 colonne con connessione aerea o a pavimento - trasmissione meccanica - 2 motori indipendenti sincronizzati elettronicamente - chiocciola doppia di sicurezza e microinterruttore anti rottura - colonne asimmetriche - potenza motore 2 x 3,6 kw - 400V/3PH-50Hz

MODEL	COLUMNS HIGHT	CAPACITY	DISTANCE BETWEEN COLUMNS	LIFTING HIGHT	DESCRIPTION
GT-EL 40	2585 mm	4.0 T	2755	65 - 1925	2 post electro-mechanical lift - extension short arms (min 640/max 1200) - extension long arms (min 775/ max 1550) - engine power 2 x 2.6kw - 400V/3PH-50Hz. CABLE CONNECTION IN THE FLOOR Sollevatore elettromeccanico a 2 colonne - bracci anteriori corti a 2 sfillo (min 640/max 1200) - bracci posteriori lunghi a 1 sfillo (min 775/max 1550) - Potenza motore 2 x 2.6kw - 400V/3PH/50Hz CONNESSIONE INCASSATA NEL PAVIMENTO
GT-EL 40 A	2585 mm	4.0 T	2755	65 - 1925	2 post electro-mechanical lift - extension short arms (min 640/max 1200) - extension long arms (min 775/ max 1550) - engine power 2 x 2.6kw - 400V/3PH. ELECTRICAL CABLE WITH AIR CONNECTION Sollevatore elettromeccanico a 2 colonne - bracci anteriori corti a 2 sfillo (min 640/max 1200) - bracci posteriori lunghi a 1 sfillo (min 775/max 1550) - Potenza motore 2 x 2.6kw - 400V/3PH/50Hz CONNESSIONE AEREA

OPTIONAL

CODE	DESCRIPTION	EL40	EL40 A
A-93007	Kit for vehicle 4WD Kit 4 tamponi speciali per veicoli 4WD	*	*
A-93008	Adaptator for Mercedes / Iveco=105 Adattatori per Mercedes / Iveco	*	*
A-93009	Adaptator for Mercedes / Iveco=135 Adattatori per Mercedes / Iveco	*	*

NOTE _____

On request: 35mm / 60mm / 160mm Extension kit
 STANDARD COLOURS: BLU RAL 5002 - GREY RAL 7016

Standard kit prolungha 35mm / 60mm / 160mm
 COLORI STANDARD: BLU RAL 5002 - GRIGIO RAL 7016

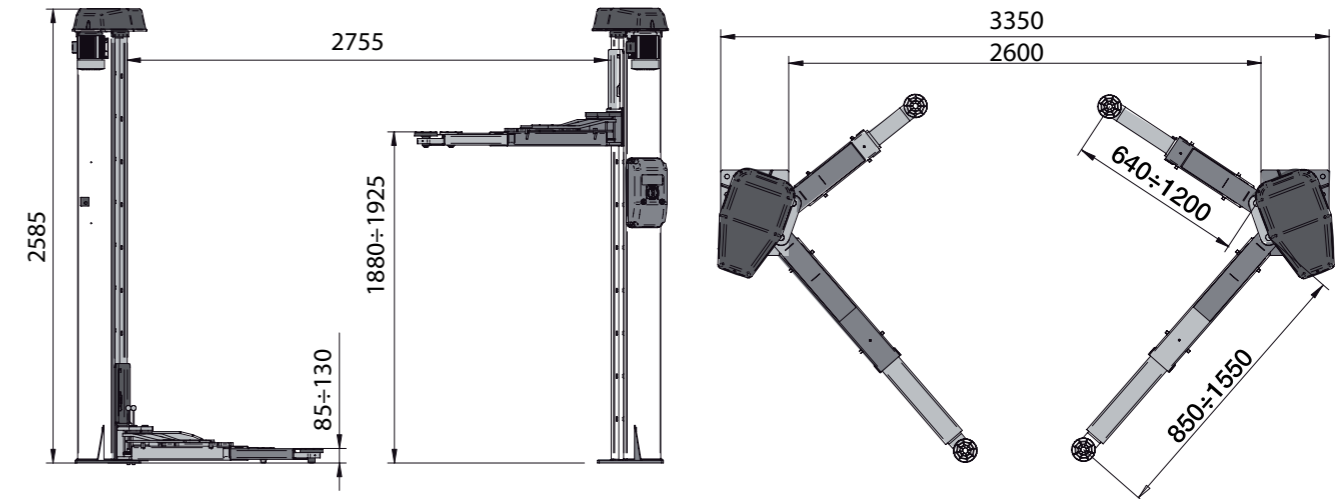

ARMS EXTENSION
ESTENSIONE BRACCI



ELECTRICAL CONTROL BOX
QUADRO ELETTRICO



RUBBER PAD
TAPPONE IN GONNE

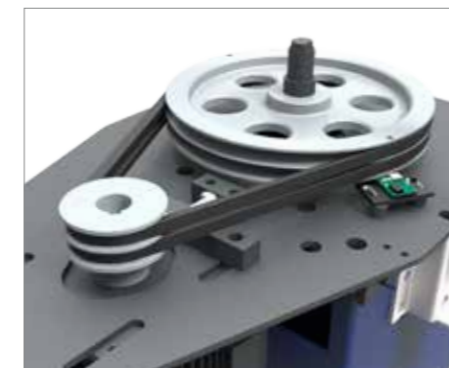

ELECTRONIC CONTROL FOR ALIGNMENT
CONTROLLO ELETTRONICO
DEI MOTORI AD OGNI GIRO DELLA
PULEGGIA



ARMS LOCK
BLOCCA BRACCI



MERCEDES/IVECO ADAPTORS
ADATTATORI MERCEDES/IVECO



GALTA

Vat. n° 04058700248

Via Vittorio Lombardi 19/21 36075 - Montecchio Maggiore (VI) Italy

Phone : +39 0444 493977 - Fax: +39 0444 495999

www.galta.it

info@galta.it