



www.es-toolbox.com



# GALTA



## GREY LINE 2 POST LIFTS



GT-AIR  
GT-TP TOP  
GT-BASEMENT

## VEHICLE LIFTS



# ITALIAN PREMIUM QUALITY

# GT - TPB 4.0 BASEMENT

Two Post Electrohydraulic lift - 2 pushing cylinders directly connected to the chained carriages - 4 mechanical safety locks with electric release - engine power 2.2KW - 400V/3PH/50HZ - On request 2.2KW - 230V/1PH/50HZ

Sollevatore elettroidraulico 2 colonne indipendenti - 2 cilindri in spinta connessi direttamente ai carrelli con catena - sgancio sicuro elettrico - 4 sicure meccaniche - potenza motore 2.2KW - 400V/3PH/50HZ - A richiesta 2.2KW - 230V/1PH/50HZ

MODEL	COLUMN (mm)	CAPACITY	COLUMN HIGHT	LIFTING HIGHT	DESCRIPTION
GT- TPB 4.0 BASEMENT	2918	4.0 T	2780	98 - 1890	Electrohydraulic lift with supporting basement - short front extension arms (min 745/max995) - long rear extension arms (min 875/max 1190) Sollevatore elettroidraulico a 2 colonne indipendenti con basamento portante - bracci anteriori corti a 1sfilo (min 745/max 955) - bracci posteriori lunghi a 1 sfilo (min 875/ max 1190)

## OPTIONAL

• Emergency Manual Descent Pump  
Pompa di emergenza manuale

• Expansion bolt set (14 pcs)  
Tasselli ad espansione (14 pcs)

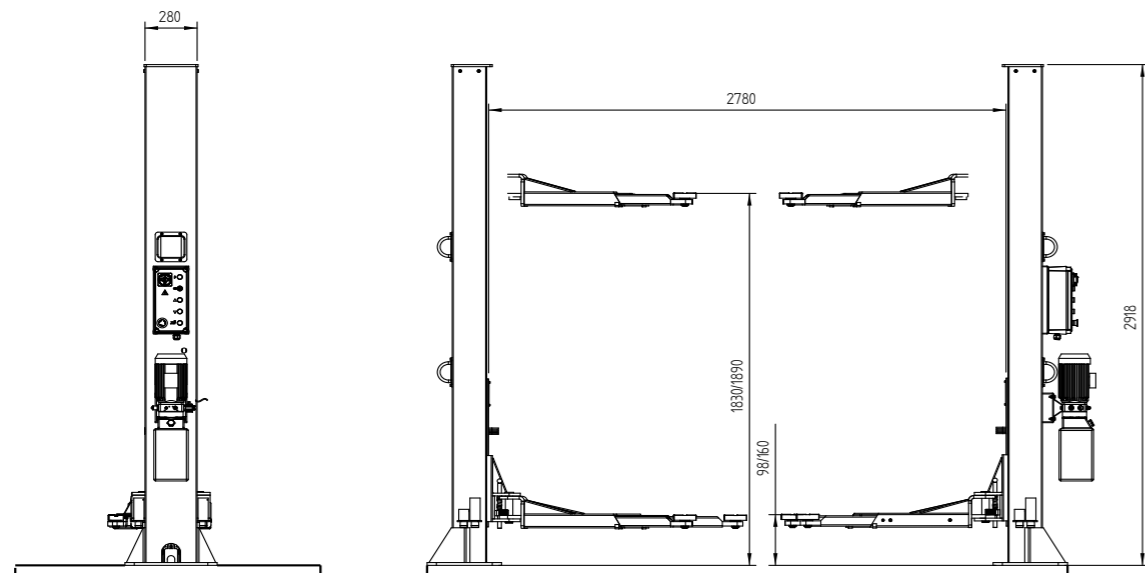

On request short arms with 2 extensions (min 680 - max 1030) and long arms with 2 extensions (min 830 - max 1380).

All our products are supplied with sandblasting.

STANDARD COLOURS: GREY RAL 7016 - GREY RAL 7040

A richiesta bracci corti a 2 sfili (min 680 - max 1030) e bracci lunghi a 2 sfili (min 830 - max 1380).

Su tutti i ponti viene applicato il trattamento di sabbiatura.

COLORI STANDARD: GRIGIO RAL 7016 - GRIGIO RAL 7040

**1** LOAD BEARING BASEMENT  
BASAMENTO PORTANTE

**2** RUBBER PROTECTION  
PROTEZIONE IN GOMMA

**3** DOUBLE ELECTROMAGNETIC SAFETY RELEASE  
DOPPIO ELETTROMAGNETE

**4** STEEL CABLE FOR MISALIGNMENT  
CAVI DI ACCIAIO ANTI DISALLINAMENTO



**4.000 Kg**

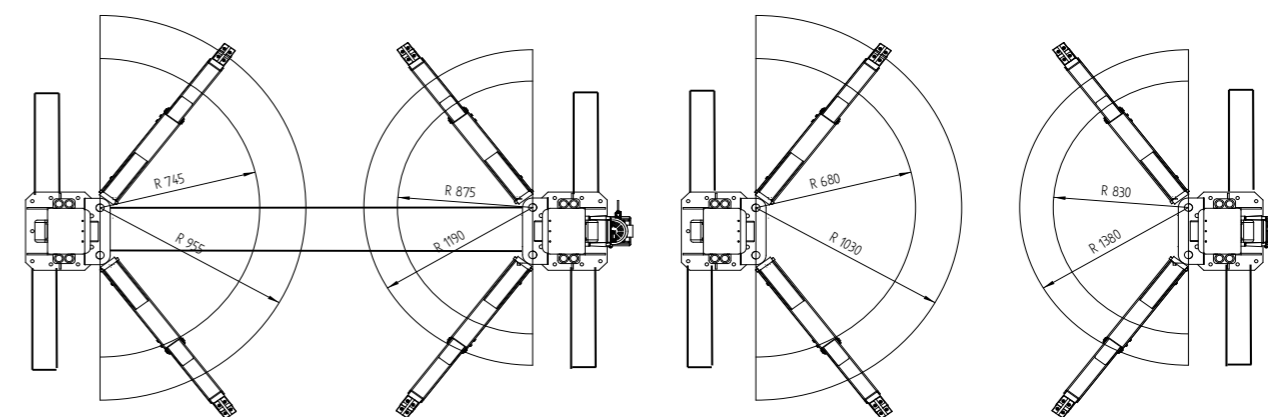

STANDARD VERSION - SINGLE EXTENSION ARM  
VERSIONE STANDARD - BRACCI A SINGOLO SFILLO

OPTIONAL VERSION - DOUBLE EXTENSION ARM  
OPTIONAL VERSION - BRACCI A DOPPIO SFILLO

# GT - TP AIR



Two Post Electrohydraulic lift - 2 pushing cylinders directly connected to the chained carriages - 4 mechanical safety locks with electric release - engine power 2.2kw - 400V/3PH/50Hz - On request 2.2KW - 230V/1PH/50HZ

Sollevatore elettroidraulico - 2 colonne indipendenti - 2 cilindri in spinta connessi direttamente ai carrelli con catena - sgancio elettrico - 4 sicure meccaniche - potenza motore 2.2kw - 400V/3PH/50Hz - A richiesta 2.2KW - 230V/1PH/50HZ

MODEL	COLUMN (mm)	CAPACITY	COLUMN HIGHT	LIFTING HIGHT	DESCRIPTION
GT- TP 4.0 AIR	2878	4.0 T	2780	98 - 1890	Electrohydraulic lift with on ground still cables/pipes/wires cover - short front extension arms (min 745/max995) - long rear extension arms (min 875/max 1190) Sollevatore elettroidraulico a 2 colonne indipendenti e canalina passatubi/cavi a pavimento - bracci anteriori corti ad 1 sfilo (min 745/max 955) - bracci posteriori lunghi a 1 sfilo (min 875/max 1190)

## OPTIONAL

• Emergency Manual Descent Pump  
Pompa di emergenza manuale

• Expansion bolt set (14pcs)  
Tasselli ad espansione (14pcs)

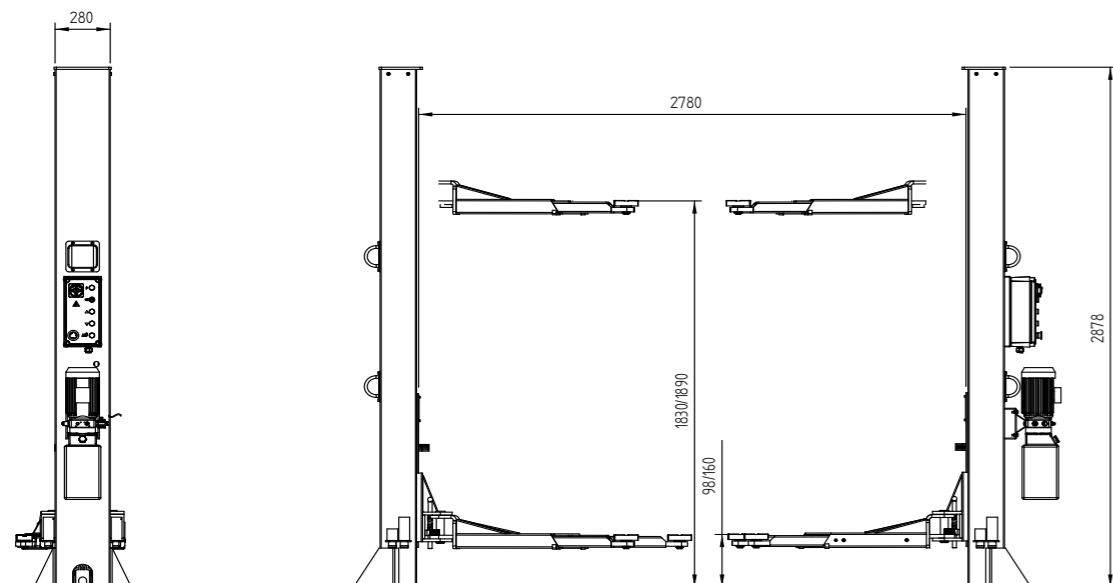

On request short arms with 2 extensions (min 680 - max 1030) and long arms with 2 extensions (min 830 - max 1380).

All our products are supplied with sandblasting.

STANDARD COLOURS: GREY RAL 7016 - GREY RAL 7040

A richiesta bracci corti a 2 sfilo (min 680 - max 1030) e bracci lunghi a 2 sfilo (min 830 - max 1380).

Su tutti i ponti viene applicato il trattamento di sabbiatura.

COLORI STANDARD: GRIGIO RAL 7016 - GRIGIO RAL 7040

**1** PIPES COVER  
CANALINA COPRITUBI

**2** RUBBER PROTECTION  
PROTEZIONE IN GOMMA

**3** DOUBLE ELECTROMAGNETIC SAFETY RELEASE  
DOPPIO ELETTROMAGNETE

**4** STEEL CABLE FOR MISALIGNMENT  
CAVI DI ACCIAIO PER L' ANTI DISALLINAMENTO



**4.000 Kg**

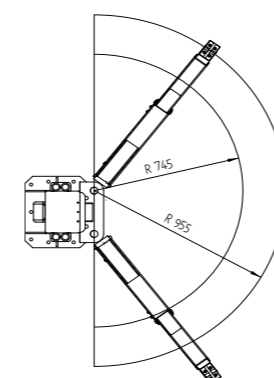

STANDARD VERSION - SINGLE EXTENSION ARM  
VERSIONE STANDARD - BRACCI A SINGOLO SFILLO

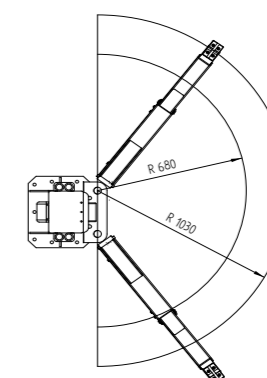
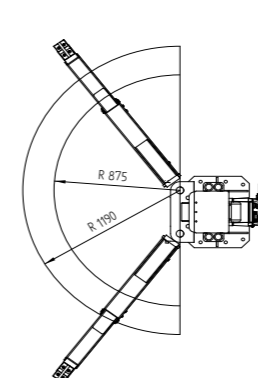

OPTIONAL VERSION - DOUBLE EXTENSION ARM  
OPTIONAL VERSION - BRACCI A DOPPIO SFILLO

# GT - TP 4.0 TOP



Two posts lift with upper connection - hydraulic drive - 2 pushing cylinders directly connected to the carriages - mechanical safety lock with electric release - standard engine power 2,2 KW - 400 V/3 PH/50 HZ - on request: 2,2 KW - 220 V/1 PH/50 HZ

Sollevatore elettro-idraulico 2 colonne con connessione aerea - trasmissione idraulica - 2 cilindri in spinta connessi direttamente ai carrelli - sgancio elettrico - sicure meccaniche - potenza motore 2.2KW - 400V/3PH/50HZ - A richiesta 2.2KW - 230V/1PH/50HZ

- 1** ANTICOLLISION BAR  
BARRA ANTI COLLISIONE
- 2** EXTENSION PAD  
PROLUNGHE TAMPONE
- 3** ELECTROMAGNETIC SAFETY RELEASE  
ELETTROMAGNETE SGANCIO SICURE
- 4** STEEL CABLE FOR MISALIGNMENT  
CAVI DI ACCIAIO PER L' ANTI DISALLINEMANTO

**4.000 Kg**

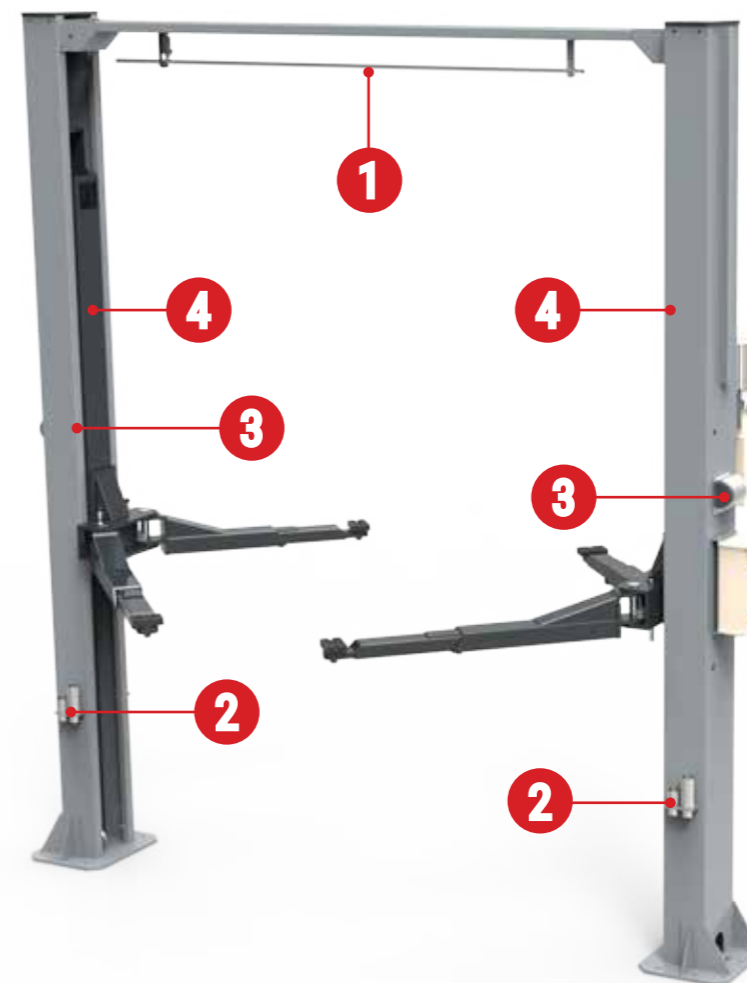

MODEL	COLUMN (mm)	CAPACITY	COLUMN HIGHT	LIFTING HIGHT	DESCRIPTION
GT- TP 4.0 TOP	3876	4.0 T	2800	98 - 1890	2 posts electrohydraulic lift with supporting crossbeam - short front extension arms (min 745/max955) - long rear extension arms ( min 875/ max 1190) Sollevatore elettro-idraulico a 2 colonne con traversa portante - bracci anteriori corti ad 1 sfilo (min 745/max 955) - bracci posteriori lunghi a 1 sfilo (min 875/max 1190)

## OPTIONAL

• Emergency Manual Descent Pump  
Pompa di emergenza manuale

• Expansion bolt set (14pcs)  
Tasselli ad espansione (14pcs)

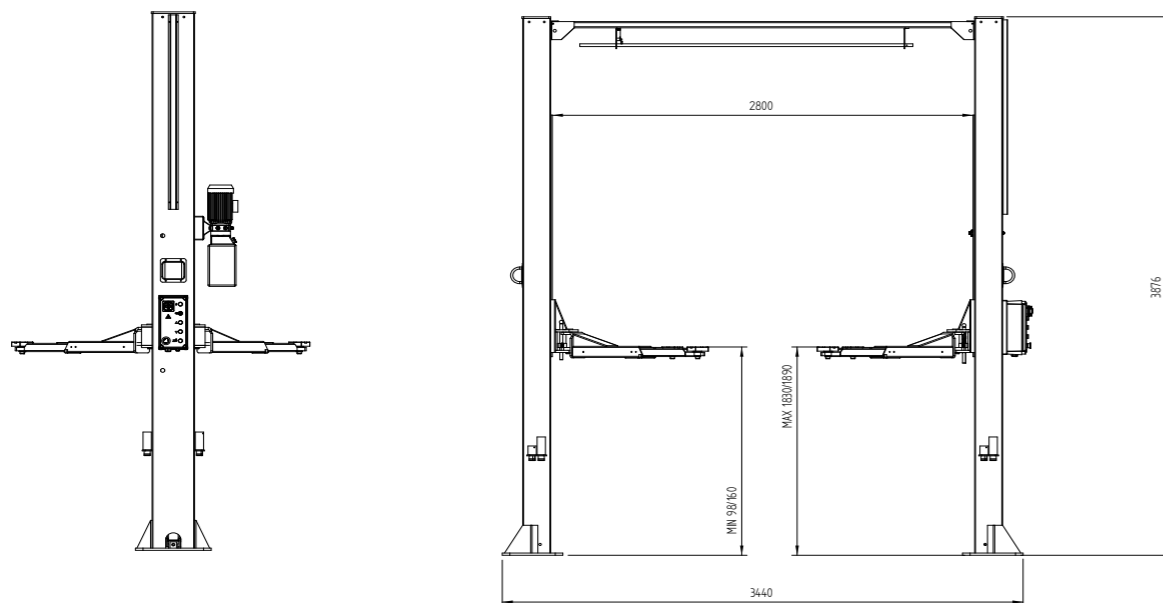

On request short arms with 2 extensions (min 680 - max 1030) and long arms with 2 extensions (min 830 - max 1380).

All our product are supplied with sandblasting.

STANDARD COLOURS: GREY RAL 7016 - GREY RAL 7040

A richiesta bracci corti a 2 sfilo (min 680 - max 1030) e bracci lunghi a 2 sfilo (min 830 - max 1380).

Su tutti i ponti viene applicato il trattamento di sabbiatura.

COLORI STANDARD: GRIGIO RAL 7016 - GRIGIO RAL 7040

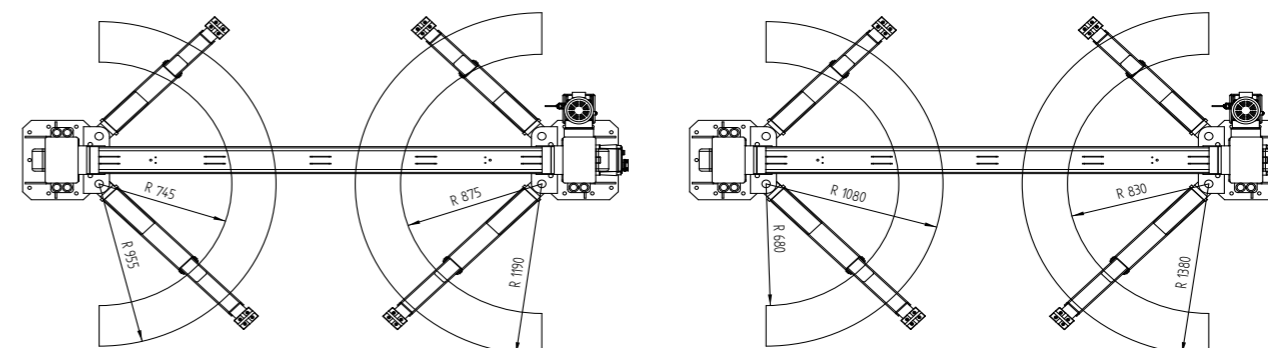

STANDARD VERSION - SINGLE EXTENSION ARM  
VERSIONE STANDARD - BRACCI A SINGOLO SFILLO

OPTIONAL VERSION - DOUBLE EXTENSION ARM  
OPTIONAL VERSION - BRACCI A DOPPIO SFILLO



# GALTA

Vat. n° 04058700248

Via Vittorio Lombardi 19/21 36075 - Montecchio Maggiore (VI) Italy

Phone : +39 0444 493977 - Fax: +39 0444 495999

[www.galta.it](http://www.galta.it)

[info@galta.it](mailto:info@galta.it)