



www.filcar.eu

Catalogo aspirazione fumi di saldatura

Welding fume extraction catalogue

Catalogue aspiration des fumée de soudure

Schweissrauchabsaugungskatalog

Catálogo aspiración de humo de soldadura



Bracci articolati

Articulated arms

Bras articulés

Schwenkarmen

Brazos articulados

5



Unità filtranti mobili

Trolley mounted filtering units

Unités mobiles de filtrage

Mobile-Filtereinheiten

Maquinas filtrantes sobre ruedas

17



Unità filtranti e filtro-aspiranti fisse

Stationary filtering units

Unités fixes pour la filtration et l'aspiration

Feste Einheiten zur Filterung und Absaugung

Maquinas aspirantes filtrantes con filtro fijas

31



Banchi aspiranti

Exhaust Benches

Tables aspirantes

Absaugwerkbäncke

Bancos aspirantes

49



Canaline in alluminio

Aluminium tracks

Rails

Saugschlitzkanäle

Carriles

55



Aspiratori

Fans

Ventilateurs

Ventilatoren

Aspiradores

61



Kit completi e componenti per impianti

Complete Kits, components and ducting

Complets Kits composants pour systeme

d'aspiration

Komplett kit bauteile für absauganlagen

Kit completos y componentes de instalación

71



Configurazioni di arredo per l'industria

Configurations of furniture for the industry

Configurations de meubles pour l'industrie

Konfigurationen von Möbeln für die Industrie

Configuraciones de muebles para la industria

81



Campi di applicazione

Fields of application

Légende

Domaines d'application

Einsatzgebiete

Campos de aplicación

88



FILCAR, ABOUT US



Filcar Spa è una realtà internazionale fondata sulla forza di un brand conosciuto in tutto il mondo. Con le sue 2 unità produttive, le società controllate sia in Italia che all'estero e i suoi innumerevoli distributori, Filcar è presente in oltre 100 paesi nel mondo. Oltre all'Italia, dove l'azienda ha consolidato una posizione di assoluto prestigio, Filcar realizza la maggior parte del proprio fatturato sul mercato europeo ed internazionale, attestandosi nelle posizioni di vertice tra i players continentali del settore. Filcar progetta, produce e vende tutti i suoi prodotti: Filcar è equamente divisa tra la vendita di componenti e la fornitura di impianti chiavi in mano. Le divisioni di Filcar sono: aspirazione gas di scarico, distribuzione fluidi ed energia, aspirazione fumi di saldatura, aspirazione polveri di carteggiatura, arredo tecnico e soluzioni logistiche per lo stoccaggio.



Filcar Spa is a global company built on the strength of an internationally renowned brand. With its 2 manufacturing units, subsidiaries both in Italy and abroad and its numerous distributors, Filcar operates in over 100 countries around the world. In addition to Italy, where the company has a well-established leading position, Filcar generates most of its turnover on European and international markets, positioning itself as a leader among the sector's continental players. Filcar designs, manufactures and sells all its products: Filcar's Business is equally divided between the sale of components and the provision of turnkey plants. The current Filcar's divisions are: Vehicle-exhaust extraction, Fluid & Energy supply, Fume extraction, Technical cabinets, Dust extraction, and Storage Systems.



Filcar S.p.A. est une entité internationale fondée sur la force d'une marque connue dantout le monde. Grâce à ses 2 établissements de production, les sociétés contrôlées aussi bien en Italie qu'à l'étranger et ses nombreux distributeurs, Filcar est présente dans plus de 100 pays du monde. En plus de l'Italie, où la société a consolidé une position de grand prestige, Filcar réalise la plupart de son chiffre d'affaires sur le marché européen et international, en se positionnant au sommet parmi les sociétés continentales du secteur. Filcar dessine, fabrique et commercialise tous ses produits: FILCAR se partage également entre la vente de composants et la fourniture de centrales clés en main. Les divisions actuelles de FILCAR sont : extraction de gaz d'échappement, distribution des fluides et de l'énergie, de l'extraction des fumées de soudure, le extraction de poussières, fournissant des solutions techniques et logistiques pour le stockage.



Filcar SpA ist ein internationales Unternehmen, das sich auf die Stärke einer weltweit bekannten Marke stützt. Mit seinen 2 Produktionseinheiten, den in Italien und im Ausland kontrollierten Unternehmen und seinen zahlreichen Vertriebspartnern ist Filcar in über 100 Ländern der Welt vertreten. Über Italien hinaus, wo sich das Unternehmen eine feste Marktposition erobert hat, erwirtschaftet Filcar den Großteil seines Umsatzes auf dem europäischen und internationalen Markt und nimmt dabei in der Branche Spitzenpositionen unter den Hauptakteuren der einzelnen Kontinente ein. Filcar entwirft, produziert und vertreibt alle seine Produkte. Die Fa. Filcar ist sowohl in der Verkauf der einzelne Komponenten, als auch in der schlüsselfertigen Anlagen tätig. Die Produktionen von FILCAR sind: Abgasabsaugung, Flüssigkeit- Energieversorgung, Schweißrauchabsaugung, Schleifstaubabsaugung, Werkstatteinrichtung und Lösungen für die Lagerung.



Filcar Spa es una realidad internacional fundada sobre la fuerza de una marca conocida en todo el mundo. Con sus 2 unidades de producción, las sociedades controladas tanto en Italia como en el exterior y sus innumerables distribuidores, Filcar está presente en más de 100 países en el mundo. Además de Italia, donde la empresa ha consolidado una posición de elevado prestigio, Filcar realiza la mayor parte de su facturación en el mercado europeo e internacional, y está posicionado entre los máximos competidores continentales del sector. Filcar estudia, produce y vende todos sus productos. Filcar vende tanto sus componentes cuantos proyectos completos llaves en la mano. Las áreas de nuestro interés son: extracción humos de escape, distribución líquidos y energía, extracción humos de soldaduras, extracción polvos de lijado, muebles técnicos y soluciones de estocaje.



La sede Operativa di Reggio Emilia

The operating center of Reggio Emilia

Le centre d'exploitation de Reggio Emilia

Das operative Zentrum von Reggio Emilia

El centro de operaciones de Reggio Emilia

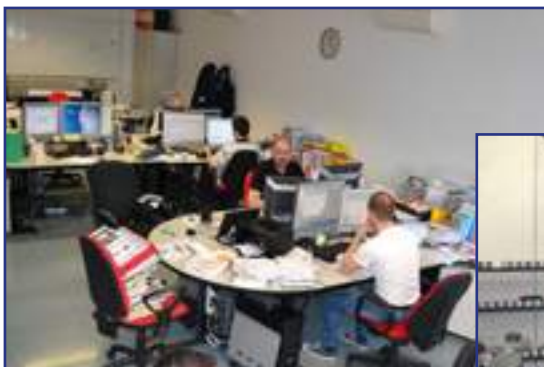



Filcar fornisce ai propri clienti servizi esclusivi che non hanno paragoni sul mercato: elevato supporto commerciale e tecnico sui prodotti della propria gamma, consulenza in fase di progettazione, sopralluogo tecnico per valutare la migliore soluzione per il cliente, proposte progettuali con ambientazioni in 3D, assistenza durante l'intera realizzazione del progetto e supporto post-vendita. Il presente catalogo illustra tutta la gamma dei prodotti disponibili di serie; per eventuali richieste di prodotti non di serie i nostri uffici commerciali sono a disposizione per lo sviluppo di nuove soluzioni. I prodotti Filcar sono coperti, in tutto il mondo, da polizza assicurativa con massimale di 5.000.000 €.



The highly professional approach and experience of Filcar's personnel allows to provide its customers with exclusive services that are beyond comparison on the market: advice during the design stage, technical surveys to identify the best solution for the customer, project proposals with 3D layouts, assistance during the entire implementation of the project, after-sales support. The Filcar catalogue shows the full range of products of the division "exhaust extraction" which are available as standard item; for any requests for not-standard products, our sales departments are available for the development of new solutions. The Filcar products are covered, worldwide, insurance policy with a limit of € 5,000,000.



La grande professionnalité et expérience du personnel Filcar permet de fournir à ses clients des services exclusifs inégalables sur le marché : consultation durant la phase de conception, état des lieux technique pour évaluer la meilleure solution pour le client, propositions de conception avec des illustrations en 3D, assistance pendant toute la réalisation du projet, assistance après-vente. Le catalogue FILCAR illustre la gamme complète des produits de la division "extraction des gaz d'échappement" disponible en standard, pour toutes les demandes de produits non-série, nos bureaux de vente sont disponibles pour le développement de nouvelles solutions. Les produits FILCAR sont couverts, dans le monde entier, l'assurance avec un plafond de € 5.000.000.



Durch die hohe Professionalität und Erfahrung des Filcar Personals können den Kunden exklusive Service-Leistungen geboten werden, die auf dem Markt unvergleichlich sind: Beratung in der Planungsphase, technischer Ortstermin, um die beste Lösung für den Kunden zu finden, Projektvorschläge mit 3D-Darstellungen, Unterstützung während der gesamten Realisierung des Projekts, After-Sales-Kundendienst. Der Katalog FILCAR zeigt die Standardprodukte für "Abgas-Absaugung"; Auf Anfragen sind personalisierte Lösungen, bzw. Produkte angeboten, bitte wenden Sie sich an unsere Verkaufsabteilung. Die FILCAR Produkte sind weltweit mit ein Maximal von € 5.000.000 versichert.



La gran profesionalidad y la experiencia del personal Filcar permiten proporcionar a sus clientes servicios exclusivos sin igual en el mercado; estos abarcan: asesoramiento en la fase de diseño, supervisión técnica para evaluar la mejor solución para el cliente, propuestas de diseño con ambientaciones 3D, asistencia durante toda la realización del proyecto y soporte de postventa. El catalogo de Filcar "extracción humos de escape" muestra la gama de serie de los artículos. Para soluciones diferentes afuera de lo presentado, la oficina técnica esta a su disposición para el desarrollo de otras soluciones. Todos los productos de Filcar estan cubiertos en todo el mundo con ua poliza de seguro hasta un limite de 5.000.000 €.

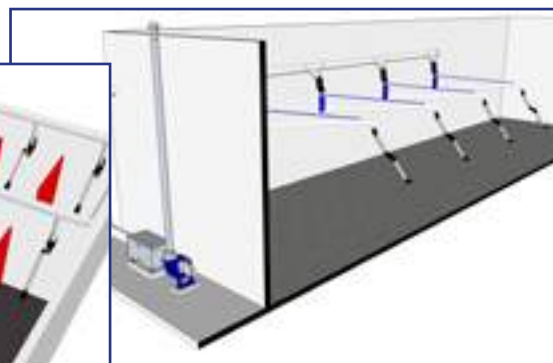
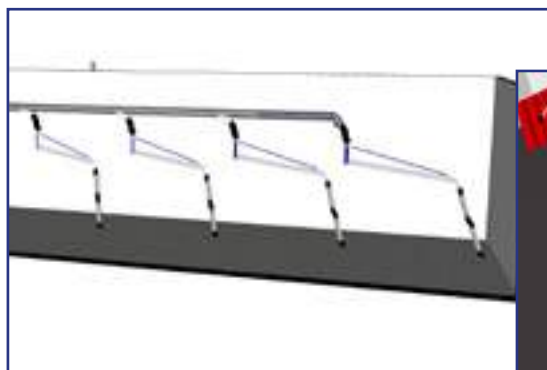



www.filcar.eu

BRACCI ARTICOLATI



ARTICULATED ARMS
BRAS ARTICULÉS
SCHWENKARMEN
BRAZOS ARTICULADOS



Braccio articolato autoportante per aspirazione fumi di saldatura. Già dotato di staffa a muro è completo di cappetta con maniglia di posizionamento e seranda di parzializzazione. Il sistema di sostegno montato esternamente garantisce bassa rumorosità, assenza di turbolenze e lunga durata delle frizioni. Disponibile in versione con prolunga a bandiera per lunghezze superiori a 5 mt. Volume di aspirazione max 1.400 m³/h.



Self-supporting, articulated arm for extracting welding fumes. Supplied with wall mounting bracket and hood complete with positioning handle and damper. The externally mounted support system guarantees low noise levels, eliminates turbulence and prolongs the working life of the joints. Available with a "flag-type" extension for lengths exceeding 5 m. Max. extraction volume 1.400 m³/h.



Bras articulé auto-portant pour l'aspiration des fumées de soudure. Prémuni d'une console murale, il est fourni avec hotte à poignée de positionnement et clapet de régulation. Le système d'articulation monté à l'extérieur garantit un faible niveau sonore, une absence de turbulences, un entretien simple et une meilleure durée de vie. Existe en version avec prolongation aspirante pour des longueurs supérieures à 5 m. Volume d'aspiration max 1.400 m³/h.



Selbsttragender Gelenkarm für die Schweißrauchabsaugung. Ausgestattet mit Wandbügel und komplett mit Absaughaube mit Handgriff zur Positionierung und Drosselklappe. Das außenliegende Trägersystem garantiert einen geräuscharmen Betrieb ohne Turbulenzen sowie eine lange Lebensdauer der Kupplungen. Erhältlich in der Version mit Schwenkausleger für Längen über 5 m. Max. Absaugvolumen 1.400 m³/h.



Brazo articulado autoportante para aspirar humos de soldadura. Incluye soporte a pared y está equipado de boca con manilla de posicionamiento y cierre de parcialización. El sistema de soporte montado externamente garantiza bajo nivel de ruido, ausencia de turbulencias y larga duración de los embragues. Versión con alargador de brazo para más de 5 m disponible. Volumen de aspiración máx.1.400 m³/h.

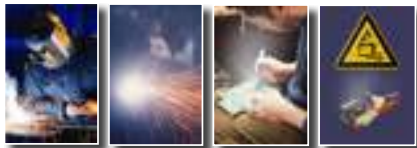

OPTIONALS

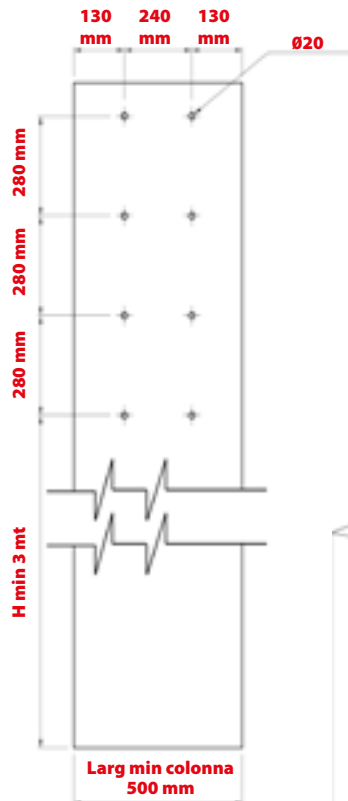

TECHNO-LIGHT
Luce 24V - 20W e trasformatore 220V
Light 24V - 20W and 220V transformer
Lumière 24V - 20W et transformateur 220V
Licht 24V - 20W und Transformator 220V
Luz 24V - 20W y transformador 220V

SPB-150
Mensola a muro
Wall support
Support murale
Wandkonsole
Soporte a pared

TECHNO-RETE
Rete antiscintilla per cappetta
Sparkproof protection net for hood
Protection anti-étincelle pour hotte
Funkenbeweisnetz für Haube
Red anticispa para campana

SSB-150
Mensola a soffitto
Ceiling support
Support au plafond
Deckenhalterung
Soporte a techo

TECHNO-RALLA
Flangia rotante per TECHNO
Rotating flange for TECHNO
Rotation pour TECHNO
Drehgelenk für TECHNO
Rodamiento para TECHNO

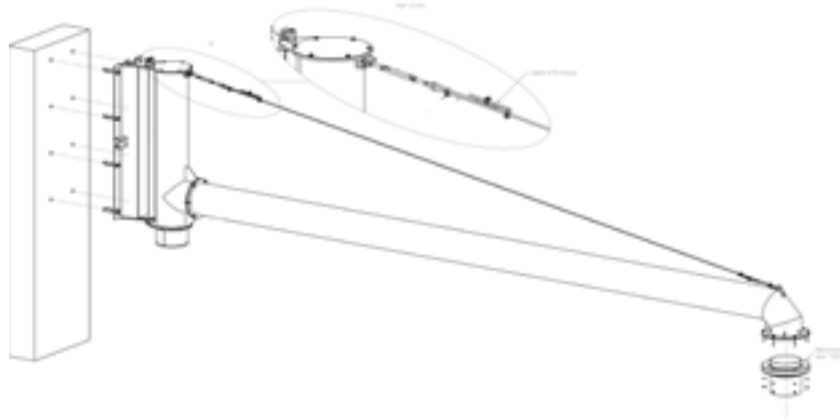

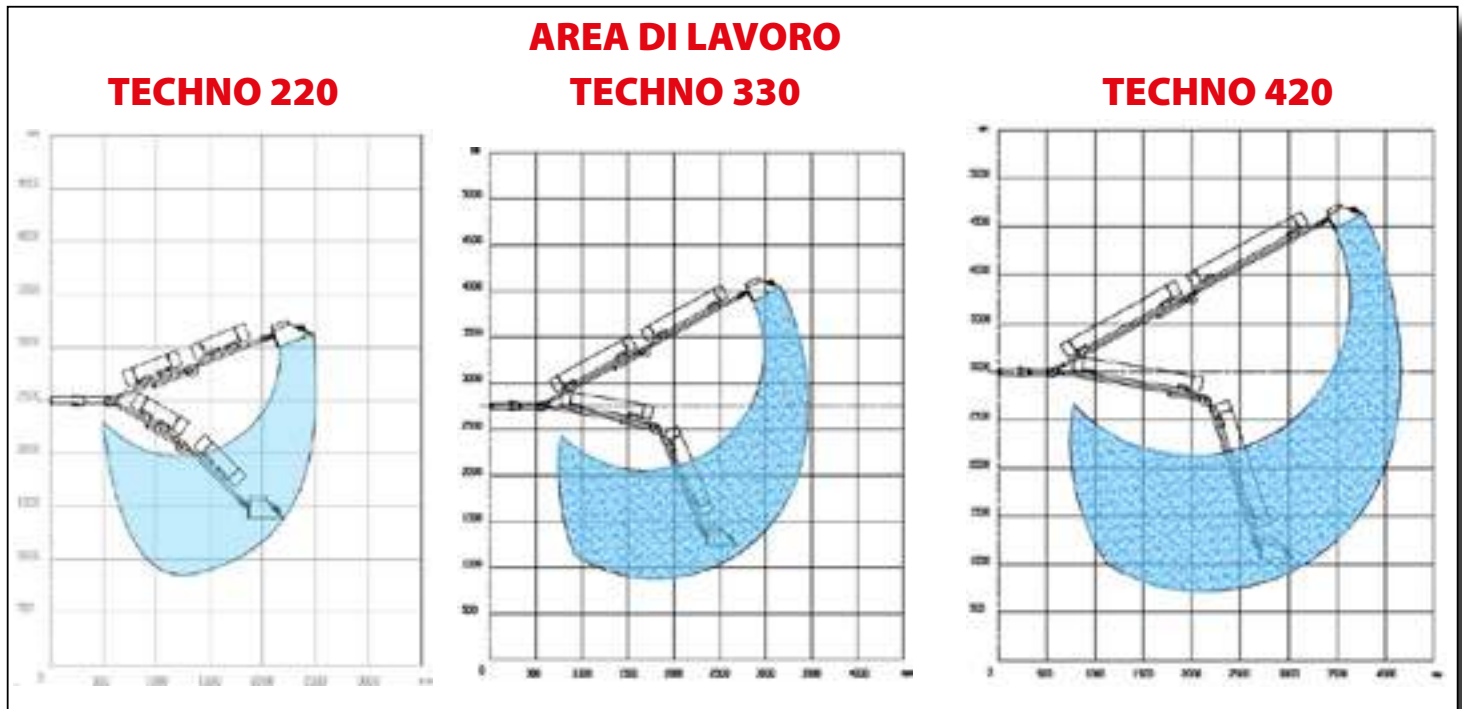

Dettagli tecnici - Technical details - Données techniques - Technische Daten - Datos Técnicos

Model										
		Mt.	Ft.	Mt.	Ft.	Mt.	Ft.	Work area °	mm.	inch.
	TECHNO-220	1,8	5,9	2,2	7,2	-	-	180°	150	6"
	TECHNO-RALLA/2	1,8	5,9	2,2	7,2	-	-	360°	150	6"
	TECHNO-330	2,8	9,2	3,3	10,9	-	-	180°	150	6"
	TECHNO-RALLA/3	2,8	9,2	3,3	10,9	-	-	360°	150	6"
	TECHNO-420	3,6	11,8	4,2	13,8	-	-	180°	150	6"
	TECHNO-RALLA/4	3,6	11,8	4,2	13,8	-	-	360°	150	6"
	TECHNO-520	4,6	15,1	5,2	17,06	-	-	180°	150	6"
	TECHNO-630	5,6	18,4	3,3	10,9	3,0	9,8	180°/360°	150	6"
	TECHNO-720	6,6	21,7	4,2	13,8	3,0	9,8	180°/360°	150	6"
	TECHNO-830	7,6	25,0	3,3	10,9	5,0	16,4	180°/360°	150	6"
	TECHNO-920	8,6	28,3	4,2	13,8	5,0	16,4	180°/360°	150	6"

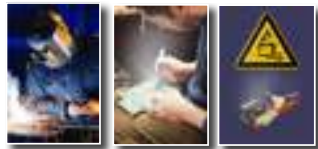

I bracci articolati ARMFLEX sono dotati di una struttura autoportante interna con 3 o 4 articolazioni a seconda del modello e presentano un tubo flessibile Ø 160 mm a copertura del supporto interno. La cappetta è in alluminio e il braccio è già dotato serrandina di parzializzazione e di ralla per una rotazione di 360°. Indicato per aspirare fumi di saldatura tramite sistemi scorrevoli o dove occorra estrema flessibilità e movimentazioni frequenti. Volume d'aspirazione max 1.200 m³/h.



ARMFLEX articulated arms are equipped with a self-supporting internal structure consisting of 3 or 4 joints, depending on the model, with a flexible Ø 160 mm hose covering the internal support. The hood is aluminium and the arm is equipped with a damper and a fifth wheel permitting it to rotate through 360°. Ideal for extracting welding fumes via sliding systems or where applications require high flexibility and frequent movements. Max extraction volume 1.200 m³/h.



Les bras articulés ARMFLEX sont équipés d'une structure autoportante interne à 3 ou 4 articulations, suivant le modèle, et présentent un tuyau flexible Ø 160 mm recouvrant la structure interne. La hotte est en aluminium et le bras est prémuné de clapet de régulation et de pivot pour une rotation de 360°. Préconisé pour l'aspiration de fumées de soudure par l'intermédiaire de systèmes coulissants ou quand une extrême souplesse et des manipulations fréquentes sont nécessaires. Volume d'aspiration max 1.200 m³/h.



Die ARMFLEX Gelenkarme verfügen über eine selbsttragende innenliegende Trägerkonstruktion mit 3 oder 4 Gelenken je nach Modell sowie einen Schlauch Ø 160 mm zur Umhüllung des inneren Trägergestells. Die Absaughaube ist aus Aluminium gefertigt und der Arm bereits mit Drosselklappe und Drehgelenk für die Drehung um 360° ausgestattet. Geeignet für das Absaugen von Schweißrauch über verfahrbaren Anlagen oder überall dort, wo extreme Flexibilität und Beweglichkeit verlangt werden. Max. Absaugvolumen 1.200 m³/h.



Los brazos articulados ARMFLEX poseen una estructura autoportante interior con 3 ó 4 articulaciones según el modelo y presentan un tubo flexible Ø 160 mm que cubre el soporte interior. La boca es de aluminio y el brazo incluye persiana de parzialización y rodamiento para rotación a 360°. Technoflex es ideal para aspirar los humos de soldadura a través de sistemas deslizantes, en zonas de trabajo donde se requiere máxima flexibilidad y es necesario efectuar desplazamientos frecuentes. Caudal de aspiración máx. 1.200 m³/h.

O P T I O N A L S

CAPPETTA-ARM-160



Cappetta in plastica
Plastic hood
Hotte en plastic
Haube aus Kunststoff
Campana de plástico



SPB-150

Mensola a muro
Wall support
Support murale
Wandkonsole
Soporte a pared







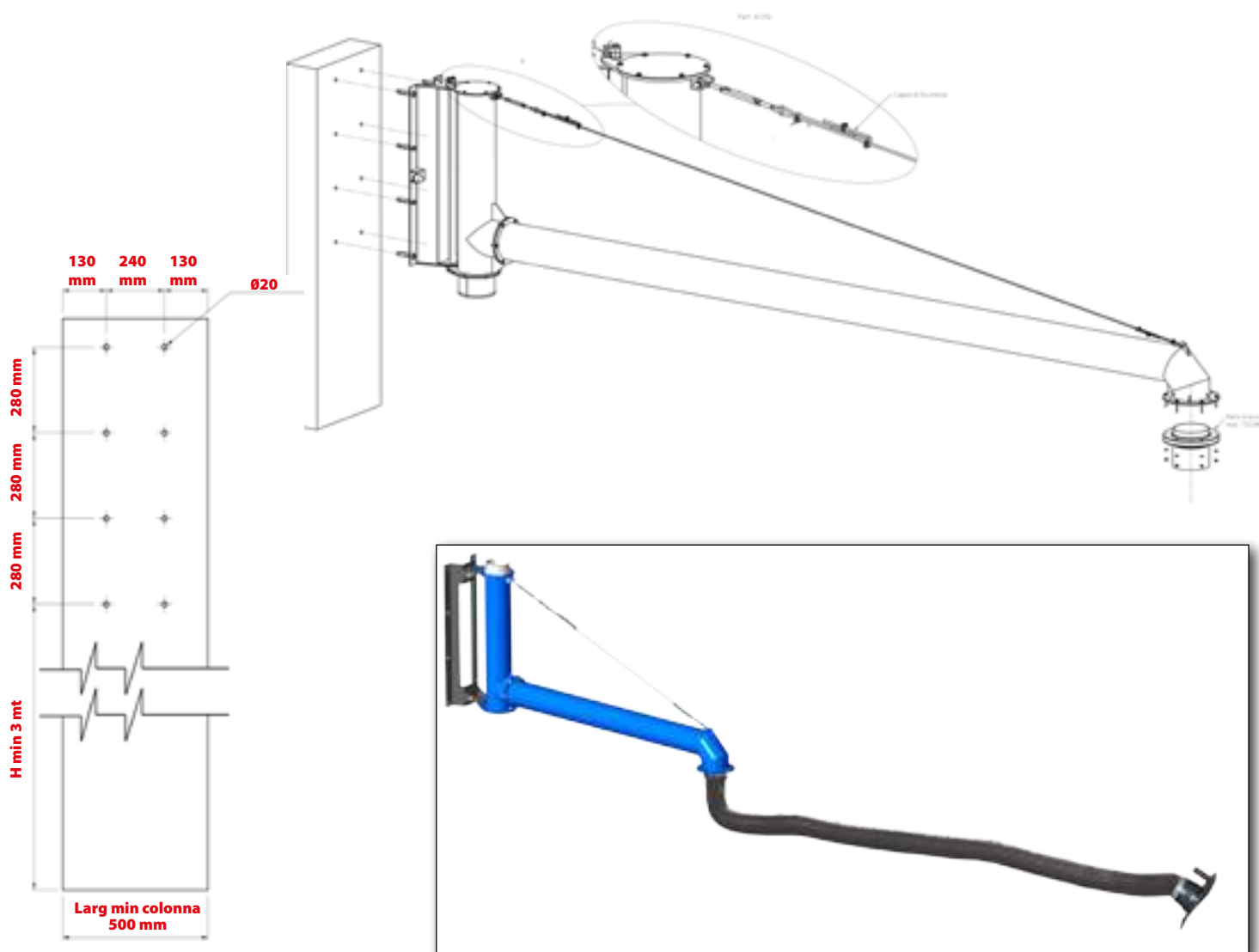

SSB-150

Mensola a soffitto
Ceiling support
Support au plafond
Deckenhalterung
Soporte a techo





Dettagli tecnici - Technical details - Données techniques - Technische Daten - Datos Técnicos

Model									
	Mt.	Ft.	Mt.	Ft.	Mt.	Ft.	mm.	inch.	
	ARMFLEX-330	2,8	9,2	3,0	9,1	-	-	160	6,3"
	ARMFLEX-420	3,6	11,8	4,0	13,1	-	-	160	6,3"
	ARMFLEX-630	5,6	18,4	3,0	9,1	3,0	9,8	160	6,3"
	ARMFLEX-720	6,6	21,7	4,0	13,1	3,0	9,8	160	6,3"
	ARMFLEX-830	7,6	25,0	3,0	9,1	5,0	16,4	160	6,3"
	ARMFLEX-920	8,6	28,3	4,0	13,1	5,0	16,4	160	6,3"

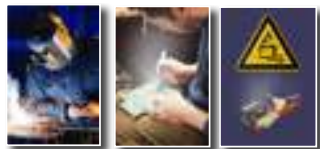

I bracci articolati TECHNOFLEX sono dotati di una struttura autoportante interna con 3 o 4 articolazioni a seconda del modello e presentano un tubo flessibile Ø 160 mm a copertura del supporto interno. La cappetta è in alluminio e il braccio è già dotato serrandina di parzializzazione e di ralla per una rotazione di 360°. Indicato per aspirare fumi di saldatura tramite sistemi scorrevoli o dove occorra estrema flessibilità e movimentazioni frequenti. Volume d'aspirazione max 1.200 m³/h.



TECHNOFLEX articulated arms are equipped with a self-supporting internal structure consisting of 3 or 4 joints, depending on the model, with a flexible Ø 160 mm hose covering the internal support. The hood is aluminium and the arm is equipped with a damper and a fifth wheel permitting it to rotate through 360°. Ideal for extracting welding fumes via sliding systems or where applications require high flexibility and frequent movements. Max extraction volume 1.200 m³/h.



Les bras articulés TECHNOFLEX sont équipés d'une structure autoportante interne à 3 ou 4 articulations, suivant le modèle, et présentent un tuyau flexible Ø 160 mm recouvrant la structure interne. La hotte est en aluminium et le bras est prémunie de clapet de régulation et de pivot pour une rotation de 360°. Préconisé pour l'aspiration de fumées de soudure par l'intermédiaire de systèmes coulissants ou quand une extrême souplesse et des manipulations fréquentes sont nécessaires. Volume d'aspiration max 1.200 m³/h.



Die TECHNOFLEX Gelenkarme verfügen über eine selbsttragende innenliegende Trägerkonstruktion mit 3 oder 4 Gelenken je nach Modell sowie einen Schlauch Ø 160 mm zur Umhüllung des inneren Trägergestells. Die Absaughaube ist aus Aluminium gefertigt und der Arm bereits mit Drosselklappe und Drehgelenk für die Drehung um 360° ausgestattet. Geeignet für das Absaugen von Schweißrauch über verfahrbaren Anlagen oder überall dort, wo extreme Flexibilität und Beweglichkeit verlangt werden. Max. Absaugvolumen 1.200 m³/h.



Los brazos articulados TECHNOFLEX poseen una estructura autoportante interior con 3 ó 4 articulaciones según el modelo y presentan un tubo flexible Ø 160 mm que cubre el soporte interior. La boca es de aluminio y la brazo incluye persiana de parzialización y rodamiento para rotación a 360°. Technoflex es ideal para aspirar los humos de soldadura a través de sistemas deslizantes, en zonas de trabajo donde se requiere máxima flexibilidad y es necesario efectuar desplazamientos frecuentes. Caudal de aspiración máx. 1.200 m³/h.

OPTIONALS



TECHNOFLEX-LIGHT

Luce 24V - 20W e trasformatore 220V
Light 24V - 20W and 220V transformer
Lumière 24V - 20W et transformateur 220V
Licht 24V - 20W und Transformator 220V
Luz 24V - 20W y transformador 220V



CAPPETTA-ARM-160

Cappetta in metallo
Enamelled hood
Hotte en metal
Haube aus Blech
Campana de metal



SPB-150

Mensola a muro
Wall support
Support murale
Wandkonsole
Soporte a pared



SSB-150

Mensola a soffitto
Ceiling support
Support au plafond
Deckenhalterung
Soporte a techo



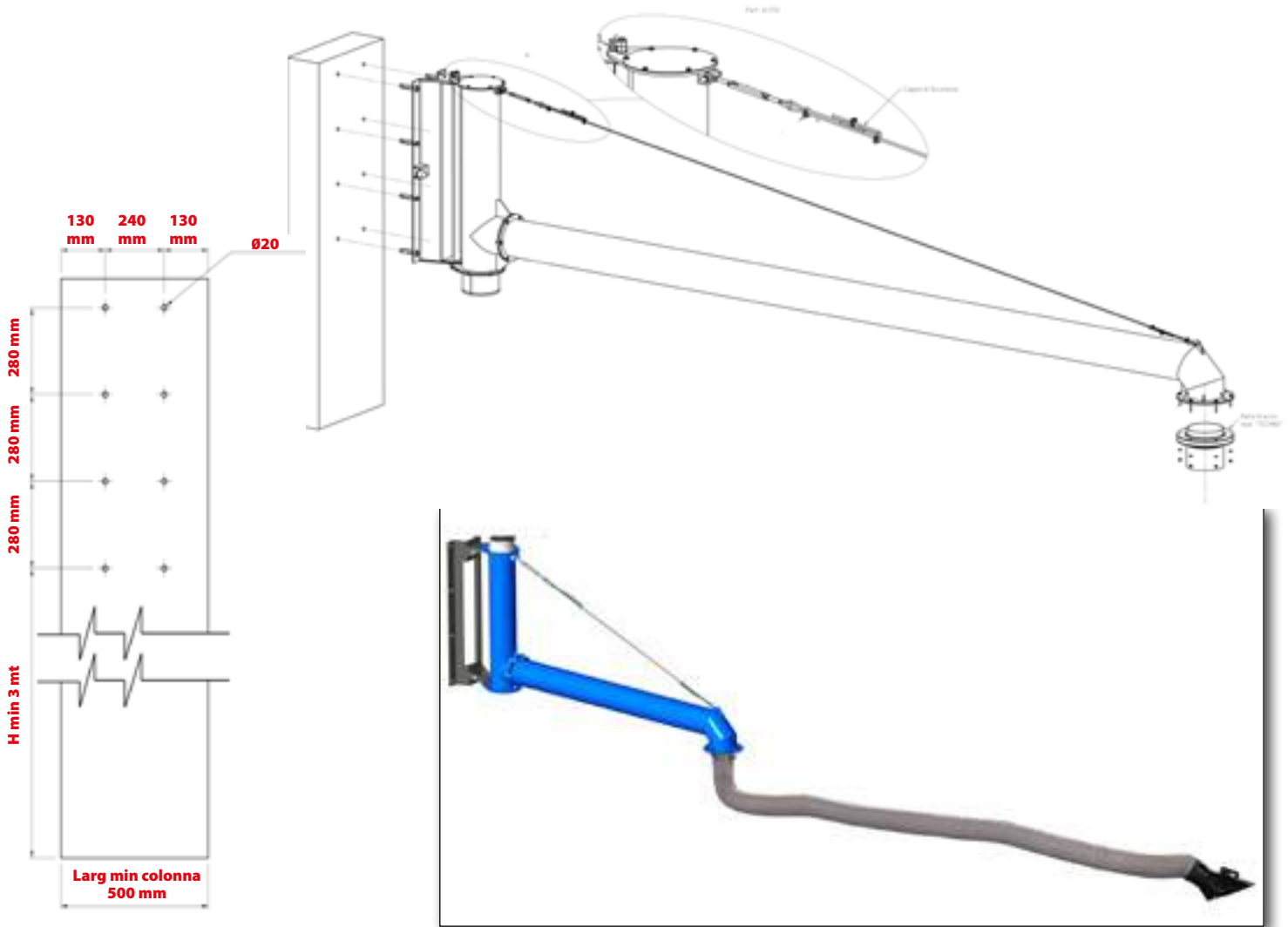

Dettagli tecnici - Technical details - Données techniques - Technishe Daten - Datos Técnicos

Model									
		Mt.	Ft.	Mt.	Ft.	Mt.	Ft.	mm.	inch.
	TECHNOFLEX-220	1,8	5,1	2,0	6,6	-	-	160	6,3"
	TECHNOFLEX-330	2,8	9,2	3,0	9,1	-	-	160	6,3"
	TECHNOFLEX-420	3,6	11,8	4,0	13,1	-	-	160	6,3"
	TECHNOFLEX-520	4,6	15,1	5,2	17	-	-	160	6,3"
	TECHNOFLEX-630	5,6	18,4	3,0	9,1	3,0	9,8	160	6,3"
	TECHNOFLEX-720	6,6	21,7	4,0	13,1	3,0	9,8	160	6,3"
	TECHNOFLEX-830	7,6	25,0	3,0	9,1	5,0	16,4	160	6,3"
	TECHNOFLEX-920	8,6	28,3	4,0	13,1	5,0	16,4	160	6,3"
	TECHNOFLEX-1020	9,6	31,4	5,0	16,4	5,0	16,4	160	6,3"

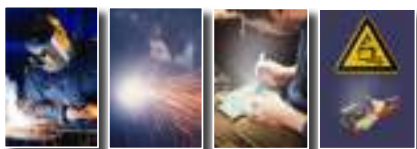

IT Il braccio autoportante DYNAMIC rappresenta la migliore soluzione tecnica per l'aspirazione dei fumi di saldatura, gas, fumi d'olio, polveri, ecc. L'aria inquinata, viene aspirata tramite la cappetta snodata, attraversa le tubazioni realizzate in robusta lamiera e giungono quindi il ventilatore. La cappetta del braccio è raccordata tramite "speciale" struttura con bilanciamento a molla, da noi brevettata, realizzata con molle, struttura in scatolato e tubo flessibile ad alta resistenza, che consentono un semplice e comodo movimento, mentre le tubazioni hanno un nuovo sistema di movimento brevettato che aumenta notevolmente la maneggevolezza. Il Dynamic inoltre è dotato di una ralla che permette una rotazione di 360°.

UK The self-supporting arm DYNAMIC represents the best technical solution for the extraction of welding fumes, gas, oil fumes, dust, etc.. The polluted air is sucked in through the articulated hood, goes through the pipes made of sturdy sheet metal and thus it reaches the ventilator. The hood of the arm is joint by a "special" structure with spring balance, patented by us, made with springs, flexible tube and boxed structure in high resistance, which allows a simple and comfortable movement, while the pipes have a new system of patented movement which greatly increases the maneuverability. The Dynamic is also equipped with a fifth wheel that allows a rotation of 360°.

FR Le bras autoporteur DYNAMIC représente la meilleure solution technique pour l'extraction des fumées de soudure, gaz, vapeurs d'huile, poussière, etc. L'air pollué est aspiré à travers le capot articulé, passe par les tuyaux en tôle robuste et arrive au ventilateur. La est rejoint par la structure «spéciale» avec l'équilibreur à ressorts, breveté par nous, fait de ressorts, tuyau flexible avec haute résistance, et la structure en boîte, ce qui permet un mouvement simple et confortable, tandis que les tuyaux ont un nouveau système de mouvement breveté qui augmente considérablement la maniabilité. Le bras Dynamic est également équipée d'une sellette d'attelage qui permet une rotation de 360°.

DE Der freitragenden DYNAMIC Arm ist die beste technische Lösung für die Extraktion von Schweißrauch, Gas, Öl Nebel, Staub, etc.. Die verschmutzte Luft wird durch den Klappdeckel angesaugt, geht durch die Rohre aus stabilem Blech und erreicht den Ventilator. Der Rauchabzug der Arm ist verbunden durch "spezielle"-Struktur mit Federzug, patentiert von uns, gemacht mit weichen, flexiblen Hochtemperatur-Schlauch und Box-Struktur, die eine einfache und komfortable Bewegung ermöglicht, während die Rohre ein neues, patentiertes Bewegung das erhöht die Manövrierfähigkeit erhöht. Der Dynamic Arm ist außerdem mit einer Sattelkupplung geeignet, die 360°-Drehung ermöglicht.

ES El brazo autoportante DYNAMIC representa la mejor solución técnica para la extracción de humos de soldadura, gases, vapores de aceite, polvo, etc. El aire contaminado es aspirado por la campana articulada, pasa por los tubos de chapa resistente y llega al aspirador. La campana está unida al brazo por una articulación "especial" hecha por equilibrador a risorte, una estructura en caja en alta resistencia y un tubo suave, flexible, patentado por nosotros, que permiten un movimiento sencillo y cómodo. La tubería tiene un nuevo sistema de movimiento patentado que aumenta en gran medida su capacidad de maniobra. El brazo autoportante Dynamic está equipado con una articulación que permite una rotación de 360°.



OPTIONALS

TECHNO-LIGHT
Luce 24V - 20W e trasformatore 220V
Light 24V - 20W and 220V transformer
Lumière 24V - 20W et transformateur 220V
Licht 24V - 20W und Transformator 220V
Luz 24V - 20W y transformador 220V

SPB-100/150/200
Mensola a muro
Wall support
Support murale
Wandkonsole
Soporte a pared

TECHNO-RETE
Rete antiscintilla per cappetta
Sparkproof protection net for hood
Protection anti-étincelle pour hotte
Funkenbeweisnetz für Haube
Red anticispa para campana

SSB-100/150/200
Mensola a soffitto
Ceiling support
Support au plafond
Deckenhalterung
Soporte a techo

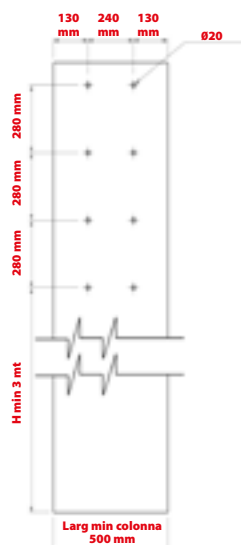

Dettagli tecnici - Technical details - Données techniques - Technishe Daten - Datos Técnicos

Model										
		Mt.	Ft.	Mt.	Ft.	Mt.	Ft.	mm.	inch.	
	DYNAMIC-210	1,7	5,6	2,0	6,6	-	-	100	4"	
	DYNAMIC-270	2,5	8,2	2,7	8,9	-	-	100	4"	
	DYNAMIC-330	2,7	8,9	2,8	9,0	-	-	150	6"	
	DYNAMIC-420	3,5	11,5	3,5	11,5	-	-	150	6"	
	DYNAMIC-630	5,7	18,7	2,8	9,0	3,0	9,8	150	6"	
	DYNAMIC-720	6,5	21,3	3,5	11,5	3,0	9,8	150	6"	
	DYNAMIC-830	7,7	25,3	2,8	9,0	5,0	16,4	150	6"	
	DYNAMIC-920	8,5	27,1	3,5	11,5	5,0	16,4	150	6"	
	DYNAMIC-350	2,7	8,9	2,8	9,0	-	-	200	8"	
	DYNAMIC-470	3,5	11,5	3,5	11,5	-	-	200	8"	
	DYNAMIC-670	5,5	18,8	3,5	11,5	2,0	6,6	200	8"	
	DYNAMIC-770	6,5	21,3	3,5	11,5	3,0	9,8	200	8"	
	DYNAMIC-870	7,5	24,7	3,5	11,5	4,0	13,1	200	8"	
	DYNAMIC-970	8,5	27,10	3,5	11,5	5,0	16,4	200	8"	

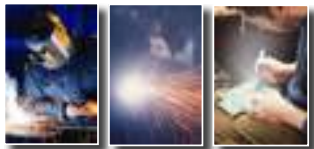

La nuova cappa modulare CLOUD CAP può adattarsi a qualsiasi esigenza individuale. E' disponibile in diverse dimensioni come standard e altre misure a richiesta. Può essere montata su gambe di supporto o sospesa a soffitto, permettendo la sua installazione anche dove non è possibile posizionare l'aspirazione direttamente alla fonte. Come optional per l'operazione di saldatura sono disponibili le tende di protezione. La CLOUD CAP ha un principio flusso innovativo, dando un rendimento particolarmente elevato di estrazione a volumi d'aria molto bassi, e quindi un consumo di energia più basso. Grazie al principio del flusso unico è possibile ottenere un' elevata efficienza di estrazione con un volume d'aria molto basso. La polvere viene aspirata attraverso aperture allungate sui bordi interni della cappa di aspirazione. La cappa di aspirazione può essere completamente attrezzata con tende per ridurre il verificarsi di scintille, proteggendo così non solo il personale, ma l'intera apparecchiatura. Inoltre, la polvere sostenute durante la saldatura e il taglio non può sfuggire grazie alle tende. La lunghezza delle strisce può essere regolata individualmente in base alle proprie esigenze.



The brand new modular extraction CLOUD CAP can fit any individual requirement. It is available in various sizes as standard and other sizes are available on request. The CLOUD CAP can be set up on supporting legs or suspended from the ceiling, allowing the hood to be placed where it is not possible to position the extraction directly at source. The hood can be fitted as optional with welding process protection curtains. CLOUD CAP has an innovative flow principle, giving it a particularly high extraction efficiency at very low air volumes, and thus lower energy consumption. Thanks to the unique flow principle it is possible to achieve a high extraction efficiency at a very low air volume. The fume produced is drawn through small, elongated openings on the inner edges of the extraction hood. The extraction hood can be fully fitted out with curtains to reduce the occurrence of sparks, thus protecting not only the staff but the entire equipment. Furthermore, the fume incurred during welding and cutting cannot escape out thanks to the hanging curtains. The length of the strips can be individually adjusted to suit specific requirements. The extraction hood is very easy to assemble, consisting mainly of parts bolted together. The intermediate profiles are connected together using corner connectors.



La nouvelle hotte aspirante modulaire CLOUD CAP peut être adaptée à de nombreuses situations individuelles. Elle est disponible en diverses dimensions soit en version standard soit sur mesure. La CLOUD CAP peut être installée sur des pieds de support ou bien suspendue, permettant son installation là où il n'est pas toujours aisé de positionner l'aspiration directement à la source. La hotte peut être équipée de rideaux de protection pour les opérations de soudure. La CLOUD CAP a un principe de flux innovant, permettant un rendement d'extraction élevée tout en ayant une quantité d'air extraite particulièrement basse, et par là même une faible consommation d'énergie. Grâce au principe du flux unique on peut obtenir une grande efficacité d'extraction tout en maintenant un débit d'air réduit. La poussière est aspirée au travers d'ouvertures oblongues sur les bords intérieurs de la hotte d'aspiration. La hotte d'aspiration peut être totalement équipée de rideaux afin de réduire et de confiner le risque d'étincelles, en protégeant ainsi non seulement le personnel mais également les machines. En outre la poussière en suspension contenue à l'intérieur de cette aire confinée pendant les opérations de soudure, la découpe de la tôle ne peut s'échapper grâce aux rideaux de protection. La longueur des ouïes d'aspiration peut être réglée individuellement en fonction des besoins.



Die neue modulare CLOUD CAP-Absaughaube können jeden individuellen Bedarf passen. Es ist erhältlich in verschiedenen Größen als Standard und andere Größen auf Anfrage. Die Haube lässt sich CLOUD CAP Stützbeine montiert oder von der Decke abgehängt, so dass die Installation selbst wenn es nicht möglich ist, um das Ansaugen direkt an der Quelle zu positionieren. Die Haube kann mit Schutzzelten für den Schweißvorgang versehen sein. Das CLOUD CAP hat eine Durchflussprinzip innovative, was einen besonders hohen Wirkungsgrad bei sehr niedrigen Extraktionsluftmengen und damit einen geringeren Energieverbrauch. Dank dem Prinzip des Single-Flow ist in der Lage, eine "hohe Effizienz der Extraktion mit einem Luftvolumen sehr niedrig ist. Der Staub wird durch die länglichen Öffnungen an den Innenkanten der Haube gesaugt. Die Haube kann vollständig mit Vorhängen ausgestattet werden, um das Auftreten von Funken zu reduzieren und schützt so nicht nur die Mitarbeiter, sondern die ganze Ausrüstung. Darüber hinaus ist die Staubentwicklung beim Schweißen und Schneiden anfallen, können nicht durch die Vorhänge hängen zu entkommen. Die Bandlänge kann individuell nach Ihren Bedürfnissen angepasst werden.



La nueva campana modular CLOUD CAP puede adaptarse a cualquier necesidad individual. Está disponible en diferentes tamaños, estándar y otras medidas a pedido. La CLOUD CAP puede ser montada sobre patas de apoyo o colgada del techo, lo que permite una instalación, en sitios complicados, donde no es posible colocar la succión directamente. La campana puede ser equipada con cortinas de protección para las operaciones de soldadura. La CLOUD CAP con un nuevo sistema de flujo de aire, permite una extracción con alta eficiencia a muy bajos volúmenes de aire y por lo tanto, con menores consumos de energía. Gracias al nuevo sistema de flujo de aire, es capaz de obtener una "alta eficiencia de extracción, con un volumen de aire muy bajos. El humo es aspirado a través de las aberturas alargadas en los bordes interiores de la campana, que como opcional, puede ser equipada con cortinas para reducir la aparición de chispas, protegiendo el personal y los equipos de soldadura. Además, utilizando las cortinas, se mejora la eficiencia de aspiración y el riesgo de que el humo pueda escapar. La longitud de las cortinas, se pueden ajustar a cada una de las necesidades.



PRINCIPIO DI FUNZIONAMENTO

Operation principle; Principe de fonctionnement; Funktionsprinzip; Funcionamiento.



OPTIONAL - ZUBEHÖR - OPCIONAL

Canalizzazione; Piping; Tuyauterie; Rohrleitung; Tuberia.



OPTIONAL - ZUBEHÖR - OPCIONAL

Tende; Curtains; Rideaux; Schutzzelten; Cortinas.

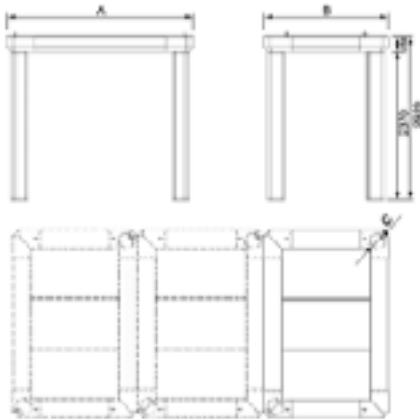

CLOUD-CAP	A (mm)	B (mm)	C N° - Ø (mm)
2x2	2000	2000	2 - 250
3x2	3000	2000	2 - 250
3x3	3000	3000	2 - 250

Dettagli tecnici - Technical details - Données techniques - Technische Daten - Datos Técnicos

Model	m ³ /h	c.f.m.	Kg	Lbs
CLOUD-CAP2X2	4320	2542	180	397
CLOUD-CAP3X2	6480	3813	220	485
CLOUD-CAP3X3	9720	5720	264	582

- I moduli base standard sopra elencati possono essere raddoppiati o triplicati nel formato per ottenere una cappa più grande quando necessario.
- Standard basic modules above listed can be doubled up in size as per draw to obtain a bigger hood when required.
- On peut doubler ou tripler les modules de base standard (indiqués ci-dessus) afin d'obtenir une hotte de plus grande dimension, selon vos besoins (2x4 - 2x6 - 3x4 - 3 x 6 - 3x9).
- Die oben aufgeführten Basismodule können erweitert werden, so dass die Erfassungshaube bedarfsgerecht modular erweitert werden kann.
- Los módulos base del elenco, pueden ser duplicados o triplicados en la forma para obtener una campana de mayor tamaño cuando fuese necesario.



 Kit partenza automatica aspirazione fumi di saldatura. Sistema che permette l'aspirazione di fumi di saldatura solo durante la fasi di saldatura effettiva.

 Automatic start set for welding fumes extraction. System that allows the extraction of welding fumes only during the active welding process.

 Kit de démarrage automatique pour l'aspiration des fumés de soudure. Système permettant l'extraction des fumées de soudure selon pendant le moment de soudage effective.

 Automatisches Ein- Ausschaltugsystem fuer Schweissrauchabsaugung, damit die Absaugung nur beim Schweissarbeiten erfolgt.

 Kit de arranque automatico de la extraccion de humos de soldadura. Sistema que permite la extracción de humos de soldadura sólo durante los pasos de soldadura real.

Model	Dettagli tecnici - Technical details - Données techniques - Technische Daten - Datos Técnicos
EM-AL-DBE	Quadro di comando (1) - Control panel (1) - Cadre de commande (1) - Schalttafel (1) - Consola de comandos (1)
EM-AL-SHUTTER	Otturatore/valvola con apertura da 0° a 90° motorizzata (Ø 80 mm - Ø 400 mm) (2) - Motorized shutter / valve with opening from 0° to 90° (Ø 80 mm - Ø 400 mm) (2) - Déclencheur / valve avec ouverture de 0° à 90° motorisé (Ø 80 mm - Ø 400 mm) (2) - Motorisierte Ventil mit Oeffnung 0° - 90° (Ø 80 mm - Ø 400 mm) (2) - Obturador / válvula con apertura de 0° a 90° motorizada (Ø 80 mm - 400 mm) (2)
EM-AL-CURRENT-SENSOR	Sensore di corrente (3) - Electricity sensor (3) - Capteur de courant (3) - Stromsensor (3) - sensor de corriente (3)



UNITÀ FILTRANTI MOBILI



TROLLEY MOUNTED FILTERING UNITS

UNITÉS MOBILES DE FILTRAGE

MOBILE-FILTEREINHEITEN

MAQUINAS FILTRANTES SOBRE RUEDAS



MINI90-NEW



Unità portatile per l'aspirazione e la filtrazione di fumi di saldatura leggera o a stagno. Dotato di cartuccia filtrante, carboni attivi e cavo di collegamento, MINI90-NEW è la soluzione pronta all'uso per lavori a banco e di precisione.



Portable unit for filtering and extracting light or tin welding fumes. Equipped with cartridge filter activated carbon cell, connections wire, MINI90-NEW is the right solution ready to be used for bench and precision work.



Unité portable pour l'aspiration et la filtration des fumées de soudure légère ou à étain. Équipé de cartouche filtrante, charbon actif et câble de connexion, MINI90-NEW est la solution prête pour le travail au banc et de précision.



Mobile Maschine fuer die Absaugung und Filterung von lichten Schweißrauch oder Hartlötten. Ausgestattet mit Filterkartuschen, Aktivhole und Kabelanschluss, MINI90-NEW ist die fertig Lösung für Werkbank und Präzisionsarbeite.



Maquinas filtrantes sobre ruedas para la aspiracion y filtracion de humos de soldadura lijera o de estaño. MINI90-NEW lleva cartuchos filtrantes de carbonos activos y cable de connexion electrico y se presenta como una rapida solucion para trabajos de precision y de mesa.



Light



MINI90-NEW

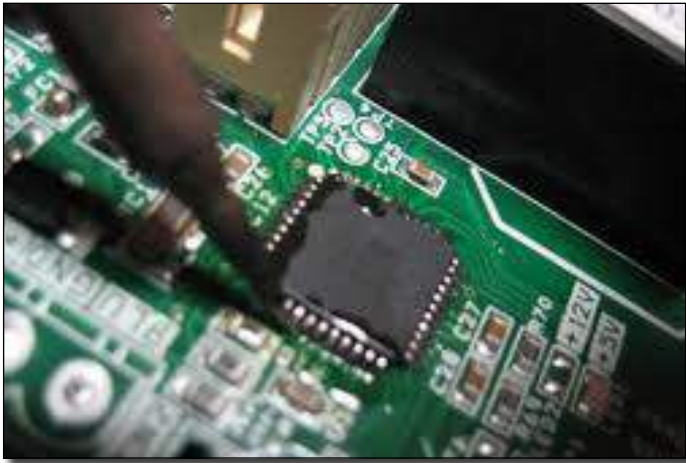

Ricambi - Spare parts - Pièces de rechange - Ersatzteile - Recambios

MINI-90/CAPPE

Supporto magnetico
Magnetic support
Support magnetique
Magnet Halterung
Soporte Magnético



MINI-90/TUBO

Ø 60 mm - L. 3 mt



MINI-90/RIC



MINI-90/CONT1

2 Kg Carboni att.
2 Kg Active Carb.
2 Kg Carbon Act.
2 Kg Aktivkohle
2 Kg Carbon Act.



Rif.	mm
A	280
B	342
C	534
D	60

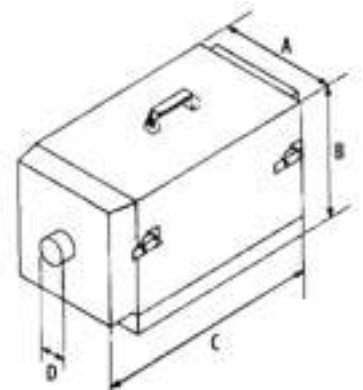

Dettagli tecnici - Technical details - Données techniques - Technische Daten - Datos Técnicos

Model	W	m ³ /h	c.f.m.	mm H ₂ O	Pa	%	Kg	Lbs	Carb. Kg	Carb. Lbs	m ²	dB	V/Hz	L. flex
MINI90-NEW	1150	140	83	2400	240	99	20	44	2	4,4	1,03	73	230/50	3 mt



ECOMINOR-FLEX - ECOMINOR-C/FLEX



Unità carrellata da 1,5 HP per l'aspirazione e la filtrazione di fumi di saldatura in impieghi poco gravosi. Agile, maneggevole e performante, ECOMINOR è equipaggiato con una batteria di 4 filtri in sequenza per filtrare meccanicamente e deodorare il fumo aspirato. Braccio autoportante articolato da 3 mt incluso. Portata max di 1.400 m³/h. Idoneo per impieghi poco gravosi.



A 1.5 HP, trolley mounted unit for extracting and filtering fumes produced in light welding applications. ECOMINOR is agile, manageable and offers high performance, it is supplied with a battery of 4 mechanical filters in sequence that filter and deodorise the fumes. A 3 m self-supporting articulated arm is included. Max capacity 1.400 m³/h. Light process.



Unité mobile de 1,5 HP pour l'aspiration et la filtration de fumées de soudure lors d'utilisations légères. Agile, maniable et puissant, ECOMINOR est équipé d'une batterie de 4 filtres successifs pour le filtrage mécanique et la désodorisation de la fumée aspirée. Equipé avec bras articulé autoportant de 3 m. Débit max de 1.400 m³/h. Emplois peu lourdes.



Fahrbare 1,5 PS Einheit für das Absaugen und Filtern von Schweißrauch für den leichteren Einsatz. ECOMINOR ist handlich, beweglich und leistungsstark und mit einer Batterie von 4 Reihenfiltern für die mechanische Filterung und Geruchsverbesserung des angesaugten Rauchs ausgestattet. Geliefert mit einen selbsttragenden Gelenkarm 3 m Lang. Max. Förderleistung 1.400 m³/h. Wenig schweren Arbeiten.



Unidad móvil de 1,5 HP para aspirar y filtrar humos de soldadura en condiciones de empleo ligero. Ágil, manejable y funcional, ECOMINOR está equipada con una batería de 4 filtros en secuencia para filtrar mecánicamente y desodorizar el humo aspirado. Equipado con brazo articulado de 3 m. Caudal máx. 1.400 m³/h. Empleos ligeros.



Light



CAPPETTA-ARM-160

Cappetta in plastica
Plastic hood
Hotte en plastic
Haube aus Kunststoff
Campana de plástico

1 FIREFILTER (cod. ECOMINOR/RIPM)

2 PREFILTER (cod. ECOMINOR/RIPS)

3 SMOKEFILTER (cod. ECOMINOR/RIF)

4 CARBOFILTER (cod. ECOMINOR/CONT)
4,5 Kg carbon

5 CARBOFILTER10 (cod. MINOR/CONT)
10 Kg carbon

ECOMINOR-FLEX



ECOMINOR-CARB /FLEX

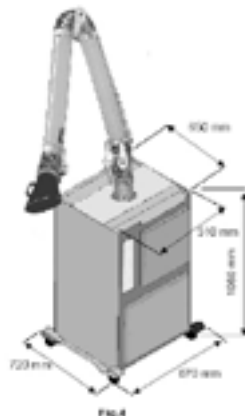

ECOMINOR-FLEX - ECOMINOR-C/FLEX



Dettagli tecnici - Technical details - Données techniques - Technische Daten - Datos Técnicos

Cleaning
Change

Model	m ³ /h	c.f.m.	%	m ²	Kg	Lbs	Carb. Kg	Carb. Lbs	h	h	V	phases	Hz	cert	HP	kW
ECOMINOR-FLEX	1400	823	95	1,03	65	143	4,5	9,9	65	250	400	3P+T	50	CE	1,5	1,1
ECOMINOR-D/FLEX	1400	823	95	1,03	65	143	4,5	9,9	65	250	400	3P+N+T	50	CE	1,5	1,1
ECOMINOR-MONO/FLEX	1400	823	95	1,03	65	143	4,5	9,9	65	250	230	1P+N+T	50	CE	1,5	1,1
ECOMINOR-CARB/FLEX	1400	823	90	0,3	72	159	10	22	65	250	400	3P+T	50	CE	1,5	1,1
ECOMINOR-CARB/220T/FLEX	1400	823	90	0,3	72	159	10	22	65	250	220	3P+T	50	CE	1,5	1,1
ECOMINOR-2/FLEX	1400	823	95	1,03	65	143	4,5	9,9	65	250	230	3P+T	50	CE	1,5	1,1
ECOMINOR-M/CARB/FLEX	1400	823	90	0,3	72	159	10	22	65	250	230	1P+N+T	50	CE	1,5	1,1

ECOMINOR-C/ FLEX

1 **FIREFILTER** (cod. ECOMINOR/RIPM)

2 **CART. IN CELLULOSA**
(cod. ECOMINOR/CART (2PCS))

IFA-BGIA
CLASSE M
99.9%



Dettagli tecnici - Technical details - Données techniques - Technische Daten - Datos Técnicos

Cleaning
Change

Model	m ³ /h	c.f.m.	%	m ²	Kg	Lbs	h	h	V	phases	Hz	cert	HP	kW
ECOMINOR-C/FLEX	1600	941	99,9	5,5	60	132	200	800	400	3P+T	50	CE	1,5	1,1
ECOMINOR-CD/FLEX	1600	941	99,9	5,5	60	132	200	800	400	3P+N+T	50	CE	1,5	1,1
ECOMINOR-CM/FLEX	1600	941	99,9	5,5	60	132	200	800	230	1P+N+T	50	CE	1,5	1,1





ECOMINOR - ECOMINOR-C



 Unità carrellata da 1,5 HP per l'aspirazione e la filtrazione di fumi di saldatura in impieghi poco gravosi. Agile, maneggevole e performante, ECOMINOR è equipaggiato con una batteria di 4 filtri in sequenza per filtrare meccanicamente e deodorare il fumo aspirato. Braccio autoportante articolato da 3 mt incluso. Portata max di 1.400 m³/h. Idoneo per impieghi poco gravosi.

 A 1.5 HP, trolley mounted unit for extracting and filtering fumes produced in light welding applications. ECOMINOR is agile, manageable and offers high performance, it is supplied with a battery of 4 mechanical filters in sequence that filter and deodorise the fumes. A 3 m self-supporting articulated arm is included. Max capacity 1.400 m³/h. Light process.

 Unité mobile de 1,5 HP pour l'aspiration et la filtration de fumées de soudure lors d'utilisations légères. Agile, maniable et puissant, ECOMINOR est équipé d'une batterie de 4 filtres successifs pour le filtrage mécanique et la désodorisation de la fumée aspirée. Equipé avec bras articulé autoportant de 3 m. Débit max de 1.400 m³/h. Emplois peu lourdes.

 Fahrbare 1,5 PS Einheit für das Absaugen und Filtern von Schweißrauch für den leichteren Einsatz. ECOMINOR ist handlich, beweglich und leistungsstark und mit einer Batterie von 4 Reihenfiltern für die mechanische Filterung und Geruchsverbesserung des angesaugten Rauchs ausgestattet. Geliefert mit einen selbsttragenden Gelenkarm 3 m Lang. Max. Förderleistung 1.400 m³/h. Wenig schweren Arbeiten.

 Unidad móvil de 1,5 HP para aspirar y filtrar humos de soldadura en condiciones de empleo ligero. Ágil, manejable y funcional, ECOMINOR está equipada con una batería de 4 filtros en secuencia para filtrar mecánicamente y desodorizar el humo aspirado. Equipado con brazo articulado de 3 m. Caudal máx. 1.400 m³/h. Empleos ligeros.



Light

1 FIREFILTER (cod. ECOMINOR/RIPM)

2 PREFILTER (cod. ECOMINOR/RIPS)

3 SMOKEFILTER (cod. ECOMINOR/RIF)

4 CARBOFILTER (cod. ECOMINOR/CONT)
4,5 Kg carbon

5 CARBOFILTER10 (cod. MINOR/CONT)
10 Kg carbon

ECOMINOR

ECOMINOR-CARB



CAPPETTA-ARM-160

Cappetta in plastica
Plastic hood
Hotte en plastic
Haube aus Kunststoff
Campana de plástico

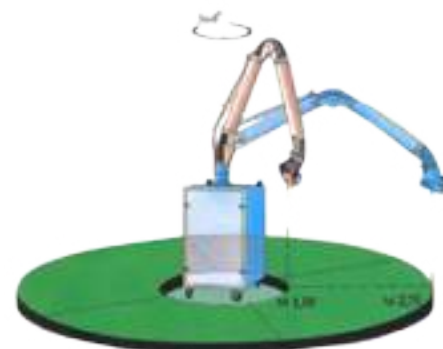
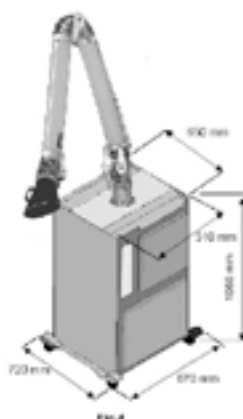

ECOMINOR - ECOMINOR-C



Dettagli tecnici - Technical details - Données techniques - Technische Daten - Datos Técnicos

Cleaning
Change

Model	m ³ /h	c.f.m.	%	m ²	Kg	Lbs	Carb. Kg	Carb. Lbs	h	h	V	phases	Hz	cert	HP	kW
ECOMINOR	1400	823	95	1,03	65	143	4,5	9,9	65	250	400	3P+T	50	CE	1,5	1,1
ECOMINOR-D	1400	823	95	1,03	65	143	4,5	9,9	65	250	400	3P+N+T	50	CE	1,5	1,1
ECOMINOR-MONO	1400	823	95	1,03	65	143	4,5	9,9	65	250	230	1P+N+T	50	CE	1,5	1,1
ECOMINOR-CARB	1400	823	90	0,3	72	159	10	22	65	250	400	3P+T	50	CE	1,5	1,1
ECOMINOR-CARB/220T	1400	823	90	0,3	72	159	10	22	65	250	230	3P+T	50	CE	1,5	1,1
ECOMINOR-2	1400	823	95	1,03	65	143	4,5	9,9	65	250	230	3P+T	50	CE	1,5	1,1
ECOMINOR-M/CARB	1400	823	90	0,3	72	159	10	22	65	250	230	1P+N+T	50	CE	1,5	1,1

ECOMINOR-C

1 **FIREFILTER** (cod. ECOMINOR/RIPM)

2 **CART. IN CELLULOSA**
(cod. ECOMINOR/CART (2PCS))

IFA-BGIA
CLASSE M
99.9%



Dettagli tecnici - Technical details - Données techniques - Technische Daten - Datos Técnicos

Cleaning
Change

Model	m ³ /h	c.f.m.	%	m ²	Kg	Lbs	h	h	V	phases	Hz	cert	HP	kW
ECOMINOR-C	1600	941	99,9	5,5	60	132	200	800	400	3P+T	50	CE	1,5	1,1
ECOMINOR-CD	1600	941	99,9	5,5	60	132	200	800	400	3P+N+T	50	CE	1,5	1,1
ECOMINOR-CM	1600	941	99,9	5,5	60	132	200	800	230	1P+N+T	50	CE	1,5	1,1



Unità carrellata per l'aspirazione e la filtrazione di fumi di saldatura. Dotata di braccio articolato da 3 mt e di una batteria di filtri ad azione meccanica per filtrare e deodorare i fumi aspirati prima della reimmissione in ambiente. Disponibile nella versione con un braccio da 150 mm, 200 mm o due bracci da 150 mm.



A trolley mounted unit for extracting and filtering welding fumes. Equipped with a 3 m articulated arm and a battery of mechanical filters that filter and deodorise the fumes before they are recycled into the environment. Available with a 150 mm and a 200 mm arm, or 2 x 150 mm arms.



Unité mobile pour l'aspiration et la filtration de fumées de soudure. Équipée de bras articulé de 3 m et d'une batterie de filtres à action mécanique pour filtrer et désodoriser les fumées aspirées avant leur réémission dans l'atmosphère. Disponible en version à un bras de 150 mm, 200 mm ou deux bras de 150 mm.



Fahrbare Einheit für das Absaugen und Filtern von Schweißrauch. Ausgestattet mit 3 m Gelenkarm und einer mechanisch wirkenden Filterbatterie zur Filterung und Geruchsverbesserung der Rauche, bevor diese wieder in den Raum zurückgeführt werden. Verfügbar in der Version mit 150 mm, 200 mm Arm oder zwei 150 mm Armen.



Unidad móvil para aspirar y filtrar humos de soldadura. Equipada con brazo articulado de 3 m y batería de filtros de acción mecánica para filtrar y desodorizar los humos aspirados antes de liberarlos en el ambiente. Disponible versión con brazo de 150 mm o 200 mm, o dos brazos de 150 mm.

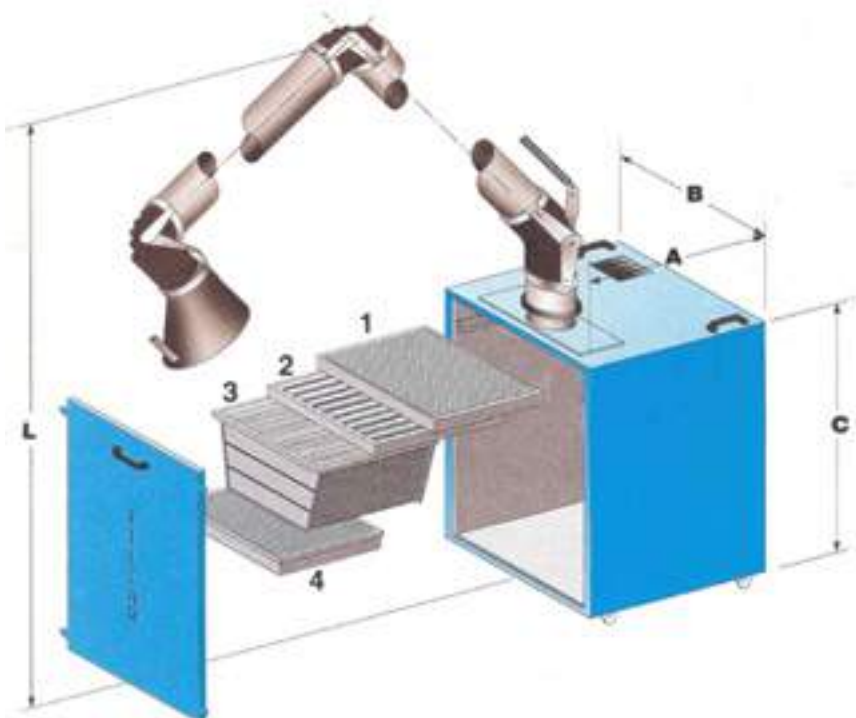

rif.	mm
A	990
B	700
C	900
L	2650

1 FIREFILTER (cod. MASTER/RIPM)

2 PREFILTER (cod. MASTER/RIPS)

3 SMOKEFILTER (cod. MASTER/RIF)

4 CARBOFILTER (cod. MASTER/CONT)
16 Kg. carbon

MASTER



MASTER-200



MASTER-2BR



HD



HD



Dettagli tecnici - Technical details - Données techniques - Technische Daten - Datos Técnicos

Cleaning
Change

Model	m ³ /h	c.f.m.	%	m ²	Kg.	Lbs.	h	h	Carb. Kg.	Carb. Lbs	V	phases	Hz	HP	Kw
MASTER-1BR	1600	882	95	17	170	375	65	1200	16	35	400	3P + T	50	3	2,2
MASTER-1BR/D	1600	882	95	17	170	375	65	1200	16	35	400	3P+N+T	50	3	2,2
MASTER-1BR/220	1600	882	95	17	170	375	65	1200	16	35	230	3P + T	50	3	2,2
MASTER-2BR	2500	1470	95	17	220	485	65	1200	16	35	400	3P + T	50	3	2,2
MASTER-2BR/D	2500	1470	95	17	220	485	65	1200	16	35	400	3P+N+T	50	3	2,2
MASTER-200	2000	1176	95	17	220	485	65	1200	16	35	400	3P + T	50	3	2,2
MASTER-200/D	2000	1176	95	17	220	485	65	1200	16	35	400	3P+N+T	50	3	2,2

MINIJET-DF1/DF2



I nuovi filtri a cartucce orizzontali MINIJET-DF1/DF2 trovano applicazione nell'aspirazione e filtrazione di fumi di saldatura, polveri fini e grossolane, trucioli in modesta quantità. Equipaggiato di braccio Techno Ø150 L 3 mt. L'aria attraversa la precamera verticale nella quale avviene, per decantazione, la separazione della maggior parte delle polveri: quelle più pesanti si depositano sul fondo nel primo cassetto di raccolta. Il successivo labirinto e la sezione filtrante con cartucce ad alta efficienza, provvedono alla filtrazione delle polveri residue che si depositano nel secondo contenitore. L'aria viene espulsa attraverso una griglia posta sulla parte superiore. Disponibile in versione con 1 e 2 cartucce.



The MINIJET-DF1/DF2 filter units equipped with horizontal cartridges are suitable for suction and filtration of welding fumes, fine and coarse dusts as well as of small quantities of chips. Equipped with an articulated arm flanged model Techno Ø150 L 3 mt. The filter unit consists of one vertical pre-chamber, where the heaviest dusts are sorted out, as a tailing pond. The dusts can fall then in a first collecting bin. The following labyrinth together with the high efficiency filtering cartridges complete the filtration of the remaining fine dusts collecting them in the second bin. Air is exhausted out through a top grill. Version available with one or two cartridges.



Les nouveaux filtres à cartouches horizontales MINIJET-DF1/DF2 trouvent application dans l'aspiration et la filtration des fumées de soudure, poussières fines ou plus importantes, copeaux en faible quantité. Equipés d'un bras Techno 150 de 3 mt. L'air traverse la préchambre dans laquelle se produit par décantation la séparation de la majeure partie des poussières: les plus lourdes se déposent dans le premier container. Le suivant labyrinthe et la section de filtre à cartouches à haute efficacité assurent une filtration de la poussière résiduelle, qui est déposée dans le deuxième récipient. L'air est éjecté à travers une grille placée sur la paroi supérieure. Disponible avec 1 et 2 cartouches.



Die neuen mobilen Absauggeräte MINIJET-DF1/DF2 mit horizontalen Filterpatronen sind geeignet für die Absaugung und Filtration von Schweißrauch, groben und feinen Stäuben, sowie für geringe Mengen an Späne. Ausgestattet mit Arm Techno 150 von 3 mt. Die schadstoffbehaftete Luft wird durch einen Zentrifugalventilator im Unterdruck angesaugt und durchströmt dabei die Vorkammer, in welcher die groben Partikel bereits vorabgeschieden werden und sich im ersten Behälter ansammeln. Das folgende Labyrinth und die Filtration durch hocheffiziente Filterpatronen sorgen für die Abscheidung der restlichen Stäube, die im zweiten Behälter dekantieren. Die Luft wird durch einen Rost an der oberen Wand angeordnet ausgeworfen. Erhältlich mit 1 und 2 Patronen.



El nuevo filtro MINIJET-DF1/DF2 con cartuchos horizontales, encuentra aplicación en la aspiración y filtración de humos de soldadura, polvos finos y gruesos en cantidades limitadas. Las maquinas son completas de una conexión apta a acoplar los brazos de aspiración modelo Techno. El aire contaminado se aspira a través del brazo y decanta en una precámara vertical donde se produce una primera pre-separación de la mayor parte de los polvos que se quedan en el primer cajón de recolección. A seguir hay un laberinto y una sección de filtración con cartuchos de alta eficiencia donde se produce la filtración de los polvos residuos. Estos polvos residuos se depositan en el segundo cajón de recolección. El aire filtrado, atraviesa el ventilador de alto rendimiento, situado en la parte superior del filtro (que garantiza una elevada capacidad de aspiración con un bajo nivel de ruido) y es expulsado a través de una red situada en la parte superior. Disponible en modelos con 1 o 2 cartuchos.

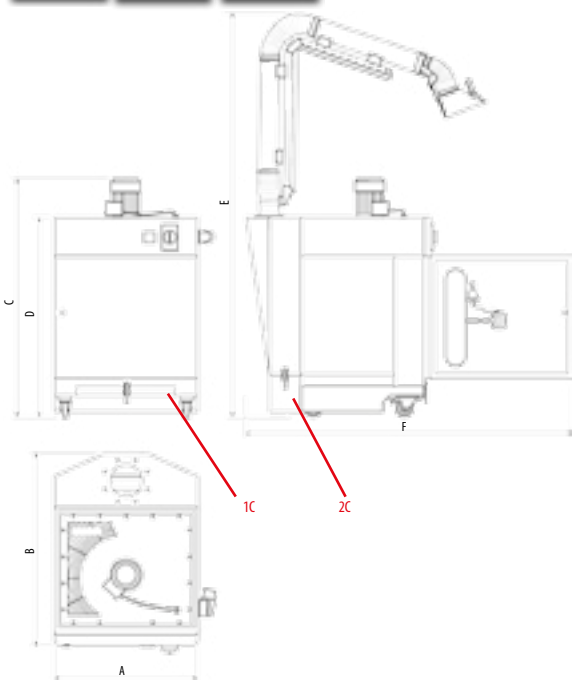
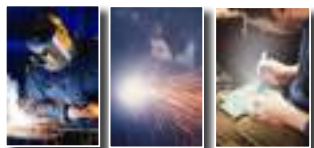

rif.	mm
A	675
B	740
C	1162
D	939
E	2360
F	1530

MINIJET-DF1

- Sistema automatico di pulizia ad aria compressa.
- Pneumatic cleaning automatic system (with compressed air).
- Système automatique de décolmatage à air comprimé.
- Einer automatischen Druckluftabreinigung.
- Sistema de limpieza por medio de aire comprimido.

1C

- Cassetto di raccolta polveri pesanti.
- Heavy dusts collection drawer.
- Tiroir pour la collecte des poussières lourdes.
- Schublade für die Sammlung von schwerere Staub.
- Cajon recupero polvo pesado.

2C

- Cassetto di raccolta polveri filtrate fini.
- Filtered dusts collection drawer.
- Tiroir pour la collecte des poussières fines et filtrées.
- Schublade für die Sammlung von feine und gefilterte Staube.
- Cajon recupero polvo filtrado fino.

Dettagli tecnici - Technical details - Données techniques - Technische Daten - Datos Técnicos

Model	m³/h	c.f.m.	%	m²	Kg	Lbs	V	phases	Hz	cert	cart.	HP	kW
MINIJET-DF1	1100	856	99,9	8	135	297,6	400	3P+N+T	50	CE	1	1	0,75

MINIJET-DF1/DF2

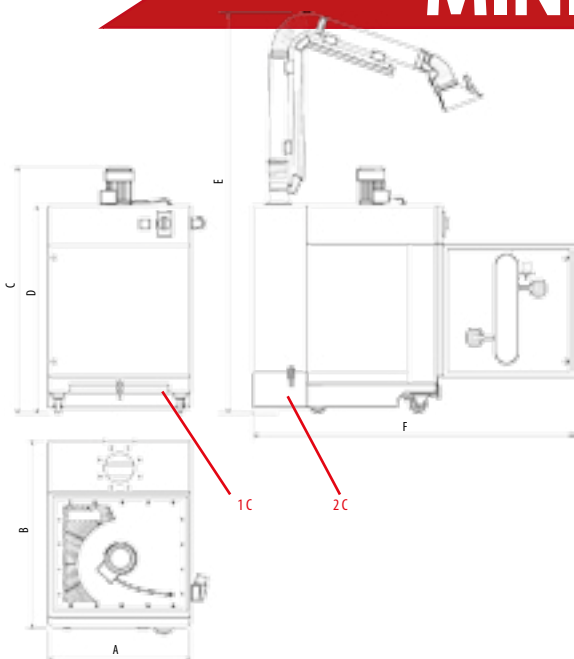

rif.	mm
A	750
B	955
C	1380
D	1158
E	2579
F	1654

MINIJET-DF2

- Sistema automatico di pulizia ad aria compressa.
- Pneumatic cleaning automatic system (with compressed air).
- Système automatique de décolmatage a air comprimé.
- Einer automatischen Druckluftabreinigung.
- Sistema de limpeza por medio de aire comprimido.

1C

- Cassetto di raccolta polveri pesanti.
- Heavy dusts collection drawer.
- Tiroir pour la collecte des poussières lourdes.
- Schublade für die Sammlung von schwerere Staub.
- Cajon recupero polvo pesado.

2C

- Cassetto di raccolta polveri filtrate fini.
- Filtered dusts collection drawer.
- Tiroir pour la collecte des poussières fines et filtrées.
- Schublade für die Sammlung von feine und gefilterte Staube.
- Cajon recupero polvo filtrado fino.

OPTIONAL



- cod. PLENUM
- Plenum insonorizzato.
- Soundproof plenum.
- Plenum insonorisé.
- Plenum insonorizado.

Dettagli tecnici - Technical details - Données techniques - Technische Daten - Datos Técnicos

Model	m ³ /h	c.f.m.	%	m ²	Kg	Lbs	V	phases	Hz	cert	cart.	HP	kW
MINIJET-DF2	1550	1109	99,9	16	170	374,8	230/400	3ph+N+T	50	CE	2	1,5	1,1

- Cartucce filtranti.
- Filtering cartridges.
- Cartouches filtrantes.
- Filterpatronen.
- Cartuchos filtrantes.

- Cartuccia in Poliestere.
- Polyester cartridges.
- Cartouches Polyester.
- Polyesterpatronen
- Cartuchos filtrantes.

cod. DF-CART/01
Ø325 - H400 mm

IFA/BGIA
M PES

filtration process

AREA INGRESSO
AIR POLLE
POLLUTED AIR
SCHMUTZLUFT
AIRE CONTAMINÉE

AREA FILTRATA
AIR FILTERED
CLEAN AIR
REIN LUFT
AIRE FILTRÉE

AREA COMPRESSA
AIR COMPRESS
DRUCKLUFT
AIRE COMPRIMÉE

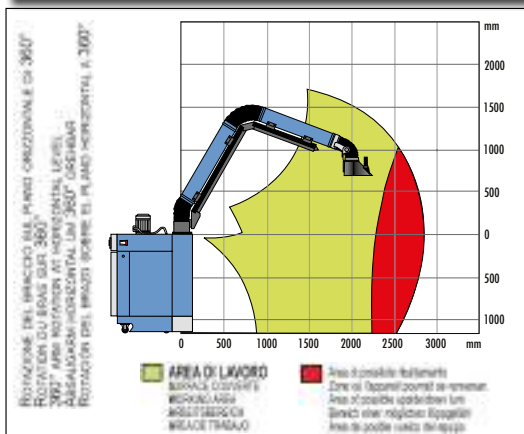

- Contatore.
- Hour meter.
- Compteur horaire.
- Stundenzähler.
- Contador de horas.



HD



I nuovi filtri a cartucce orizzontali MASTERJET-DF2 trovano applicazione nell'aspirazione e filtrazione di fumi di saldatura, polveri fini e grossolane, trucioli in modesta quantità. Equipaggiato di braccio Techno Ø150 L 3 mt. L'aria attraversa la precamera verticale nella quale avviene, per decantazione, la separazione della maggior parte delle polveri: quelle più pesanti si depositano sul fondo nel primo cassetto di raccolta. Il successivo labirinto e la sezione filtrante con cartucce ad alta efficienza, provvedono alla filtrazione delle polveri residue che si depositano nel secondo contenitore. L'aria viene espulsa attraverso una griglia posta sulla parte superiore. Disponibile in versione con 1 e 2 cartucce.



The MASTERJET-DF2 filter units equipped with horizontal cartridges are suitable for suction and filtration of welding fumes, fine and coarse dusts as well as of small quantities of chips. Equipped with an articulated arm flanged model Techno Ø150 L 3 mt. The filter unit consists of one vertical pre-chamber, where the heaviest dusts are sorted out, as a tailing pond. The dusts can falling then in a first collecting bin. The following labyrinth together with the high efficiency filtering cartridges complete the filtration of the remaining fine dusts collecting them in the second bin. Air is exhausted out through a top grill. Version available with one or two cartridges.



Les nouveaux filtres à cartouches horizontales MASTERJET-DF2 trouvent application dans l'aspiration et la filtration des fumées de soudure, poussières fines ou plus importantes, copeaux en faible quantité. Equipés d'un bras Techno 150 de 3 mt. L'air traverse la préchambre dans laquelle se produit par décantation la séparation de la majeure partie des poussières: les plus lourdes se déposent dans le premier container. Le suivant labyrinthe et la section de filtre à cartouches à haute efficacité assurent une filtration de la poussière résiduelle, qui est déposée dans le deuxième récipient. L'air est éjecté à travers une grille placée sur la paroi supérieure. Disponible avec 1 et 2 cartouches.



Die neuen mobilen Absauggeräte MASTERJET-DF2 mit horizontalen Filterpatronen sind geeignet für die Absaugung und Filtration von Schweißrauch, groben und feinen Stäuben, sowie für geringe Mengen an Späne. Ausgestattet mit Arm Techno 150 von 3 mt. Die schadstoffbehaftete Luft wird durch einen Zentrifugalventilator im Unterdruck angesaugt und durchströmt dabei die Vorkammer, in welcher die groben Partikel bereits vorabgeschieden werden und sich im ersten Behälter ansammeln. Das folgende Labyrinth und die Filtration durch hocheffiziente Filterpatronen sorgen für die Abscheidung der restlichen Stäube, die im zweiten Behälter dekantieren. Die Luft wird durch einen Rost an der oberen Wand angeordnet ausgeworfen. Erhältlich mit 1 und 2 Patronen.



El nuevo filtro MASTERJET-DF2 con cartuchos horizontales, encuentra aplicación en la aspiración y filtración de humos de soldadura, polvos finos y gruesos en cantidades limitadas. Las maquinas son completas de una conexión apta a acoplar los brazos de aspiración modelo Techno. El aire contaminado se aspira a través del brazo y decanta en una precámara vertical donde se produce una primera pre-separación de la mayor parte de los polvos que se quedan en el primer cajón de recolección. A seguir hay un laberinto y una sección de filtración con cartuchos de alta eficiencia donde se produce la filtración de los polvos residuos. Estos polvos residuos se depositan en el segundo cajón de recolección. El aire filtrado, atraviesa el ventilador de alto rendimiento, situado en la parte superior del filtro (que garantiza una elevada capacidad de aspiración con un bajo nivel de ruido) y es expulsado a través de una red situada en la parte superior. Disponible en modelos con 1 o 2 cartuchos.

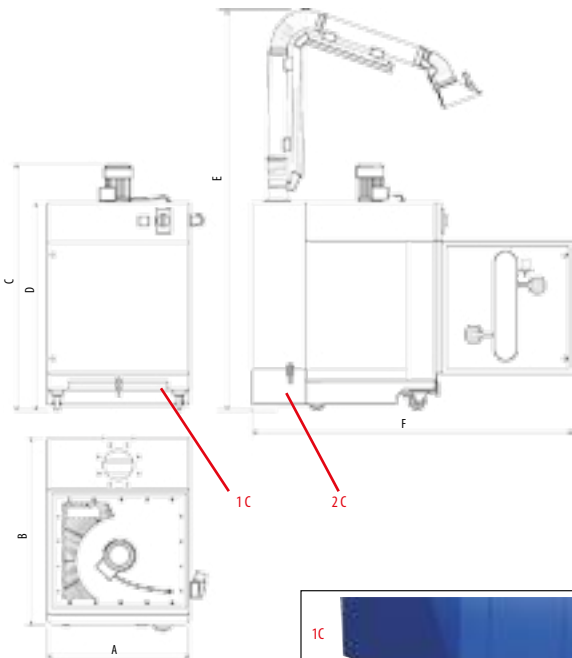

rif.	mm
A	750
B	955
C	1380
D	1158
E	2579
F	1654



- Sistema automatico di pulizia ad aria compressa.
- Pneumatic cleaning automatic system (with compressed air).
- Système automatique de décolmatage à air comprimé.
- Einer automatischen Druckluftabreinigung.
- Sistema de limpieza por medio de aire comprimido.

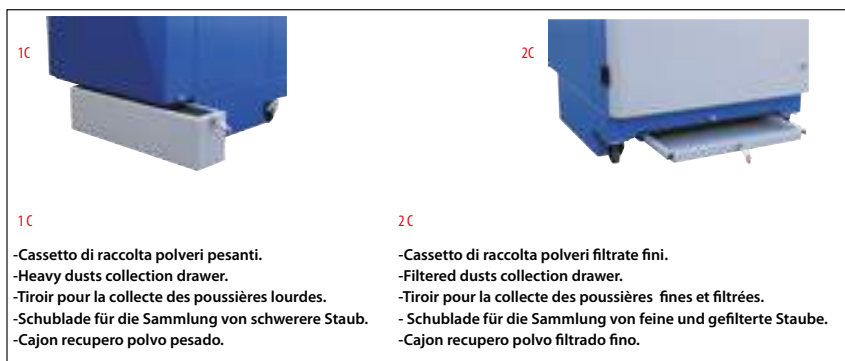

1C

- Cassetto di raccolta polveri pesanti.
- Heavy dusts collection drawer.
- Tiroir pour la collecte des poussières lourdes.
- Schublade für die Sammlung von schwerere Staub.
- Cajon recupero polvo pesado.

2C

- Cassetto di raccolta polveri filtrate fini.
- Filtered dusts collection drawer.
- Tiroir pour la collecte des poussières fines et filtrées.
- Schublade für die Sammlung von feine und gefilterte Staube.
- Cajon recupero polvo filtrado fino.

OPTIONAL



- cod. PLENUM
- Plenum insonorizzato.
- Soundproof plenum.
- Plenum insonorisé.
- Plenum insonorizado.

MASTERJET-DF2



MASTERJET-DF2-200



MASTERJET-DF2-2BR

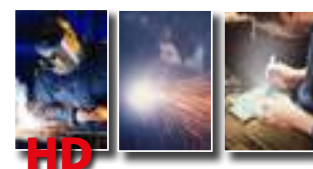

Dettagli tecnici - Technical details - Données techniques - Technische Daten - Datos Técnicos

Model	m ³ /h	c.f.m.	%	m ²	Kg	Lbs	V	phases	Hz	cert	cart.	HP	KW
MASTERJET-DF2-1BR	1500	1345	99,9	16	185	407,9	400	3P+N+T	50	CE	2	3	2,2
MASTERJET-DF2-2BR	2500	1345	99,9	16	210	462,9	400	3P+N+T	50	CE	2	3	2,2
MASTERJET-DF2-200	2000	1345	99,9	16	190	418,8	400	3P+N+T	50	CE	2	3	2,2

cod. DF-CART/01
Ø325 - H400 mm

**IFA/BGIA
M PES**

- Cartucce filtranti.
- Filtering cartridges.
- Cartouches filtrantes.
- Filterpatronen.
- Cartuchos filtrantes.

- Cartuccia in Poliestere.
- Polyester cartridges.
- Cartouches Polyester.
- Polyesterpatronen.
- Cartuchos filtrantes.

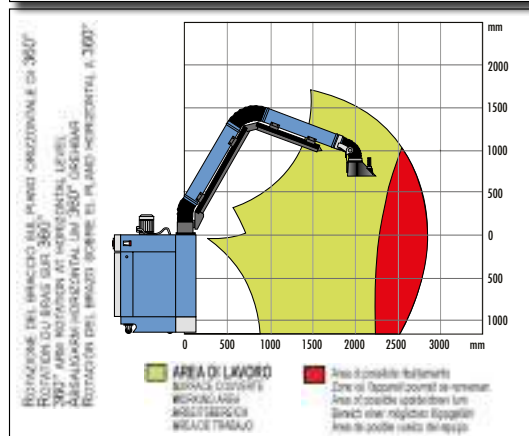

- Contatore.
- Hour meter.
- Compteur horaire.
- Stundenzähler.
- Contador de horas.



www.filcar.eu

UNITÀ FILTRANTI E FILTRO-ASPIRANTI FISSE



**STATIONARY UNITS AND FILTER FILTERING AND EXTRACTING
UNITÉS FIXES POUR LA FILTRATION ET L'ASPIRATION
FESTE EINHEITEN ZUR FILTERUNG UND ABSAUGUNG
MAQUINAS ASPIRANTES FILTRANTES CON FILTRO FIJAS**



SUPERJET-DF



Il nuovo filtro a cartucce orizzontali SUPERJET-DF trova applicazione nell'aspirazione e filtrazione di fumi di saldatura, polveri grossolane e fini, trucioli in modesta quantità, polveri/fumi da taglio termico. Il gruppo è costituito da una precamera, dove la maggior parte delle polveri grossolane viene separata e si deposita nel primo cassetto di raccolta; il successivo labirinto e la sezione filtrante con cartucce ad alta efficienza provvedono alla filtrazione delle polveri residue. Il ventilatore ad alto rendimento, posto nella parte alta dell'unità, garantisce un'elevata capacità di aspirazione ed una bassa rumorosità.



The new SUPERJET-DF equipped with horizontal cartridges is suitable for suction and filtration of welding fumes, fine and coarse dusts as well as of small quantities of chips, dusts/fumes from thermal cutting. The filter unit consists of one pre chamber, where the most dusts are sorted out, falling then in the first collecting bin. The following labyrinth together with the high efficiency filtering cartridges and the second collecting bin complete the filtration of the remaining dusts. The high performance fan, placed just on the top of the unit, assures a high suction capacity and a low noise level.



Le nouveau filtre a cartouches horizontale SUPERJET-DF a été conçu pour l'aspiration et la filtration des fumées de soudure, poussières, de la plus fine a la plus grossière, certains types de copeaux en faible quantité, poussières et fumées de découpe laser. Le groupe est constitué d'une préchambre de décompression dans laquelle la majeure partie des polluants sont séparés et se déposent dans le premier caisson de récupération. La chicane qui suit et la partie filtration constituée de cartouches filtrantes a tres haute efficacité permettent une filtration des poussières résiduelles. Le motoventilateur a haut rendement, positionné dans la partie haute du groupe, fonctionne en dépression, assure une grande capacité d'aspiration et une niveau sonore particulièrement faible.



Das neue Filtergerät mit horizontalen Filterpatronen SUPERJET-DF findet die optimale Anwendung bei der Absaugung und Filtration von Schweißrauch, feinen und groben Stäuben, kleine Mengen an Späne, sowie Stäube und Rauch aus Laser- und Plasmaschneiden. Das Gerät besteht aus einer Vorkammer, bei welcher die groben Stäube bereits abgetrennt werden und sich in den ersten Behälter ansammeln; das nachstehende Labyrinth und die Filterkammer mit Hochleistungspatronen gewährleisten die Filtration der Reststäube. Der im oberen Teil des Gerätes angeordnete Ventilator garantiert eine hohe Saugleistung und einen niedrigen Lärmemission.



El nuevo filtro SUPERJET-DF con cartuchos horizontales, encuentra aplicación en la aspiración y filtración de humos de soldadura, polvos finos y gruesos en cantidades limitadas y polvos/humos procedentes de corte termico. El equipo está constituido por una pre cámara, donde se produce una primera pre-separación de la mayor parte de los polvos, que se depositan en el primer cajón de recolección. A seguir hay un laberinto y una sección de filtración con cartuchos de alta eficiencia donde se produce la filtración de los polvos residuos. Estos polvos residuos se depositan en el segundo cajón de recolección. El aire filtrado, atraviesa el ventilador de alto rendimiento, situado en la parte superior del filtro que garantiza una elevada capacidad de aspiración con un bajo nivel de ruido.

SUPERJET	A	A1	B	C	D	E	F	G	H	I	L	M
DF4/DF4R/ THERMALCUT	930	-	1120	1610	1915	1015	1210	2085	2043	866	838	433
DF6/ THERMALCUT	1100	-	1315	1805	2130	1190	1210	2260	2358	1038	840	553
DF9/ THERMALCUT	-	1500	1495	1979	2354	-	1293	2540	2532	1293	980	553



- Plenum insonorizzato.
- Soundproof plenum.
- Plenum insonorisé.
- Schalldämmhaube.
- Plenum insonorizado.



- Quadro elettrico per DF4 e DF6 (standard solo nel DF9).
- Electric control board for DF4 and DF6 (standard only in DF9).
- Armoire électrique pour DF4 et DF6 (standard seulement dans DF9).
- Schaltschrank für DF4 und DF6 (standard nur in DF9).
- Tablero eléctrico para DF4 y DF6 (standard sólo en DF9).

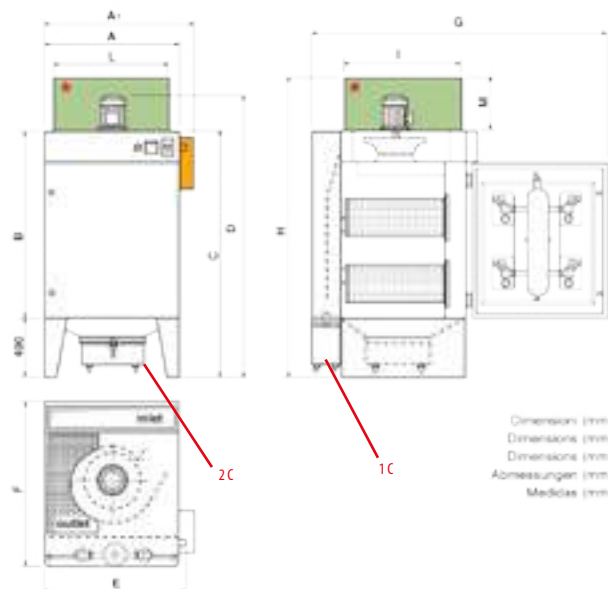

Dimensioni (mm)
Dimensions (mm)
Dimensions (mm)
Abmessungen (mm)
Medidas (mm)



1C

- Cassetto di raccolta polveri pesanti.
- Heavy dusts collection drawer.
- Tiroir pour la collecte des poussières lourdes.
- Schublade für die Sammlung von schwerere Staub.
- Cajón recupero polvo pesado.



2C

2C

- Cassetto di raccolta polveri filtrate fini.
- Filtered dusts collection drawer.
- Tiroir pour la collecte des poussières fines et filtrées.
- Schublade für die Sammlung von feine und gefilterte Staube.
- Cajón recupero polvo filtrado fino.



IFA/BGIA-PTFE/MEMBRANE

cod. SUPERJET-DF-CART/MEMBRANE
Ø325 - H750 mm (B)

- Cartucce filtranti.
- Filtering cartridges.
- Cartouches filtrantes.
- Filterpatronen.
- Cartuchos filtrantes.

- Poliestere-membrana teflon
- Polyester-teflon membrane
- Polyester-membrane de teflon
- Polyester-ptfe- membran
- Poliéster-membrane de teflon

M PES

cod. SUPERJET-DF-CART/MPES
Ø325 - H750 mm (A)

cod. SUPERJET-DF-CART/NANOTECH
Ø325 - H660 mm (C)

- Cartuccia in Poliestere.
- Polyester cartridges.
- Cartouches Polyester.
- Polyesterpatronen.
- Cartuchos filtrantes.

- Cellulosa con nanofibre
- Cellulose with nanofibers
- Cellulose avec nanofibres
- Zellulose mit nanofaser
- Celulosa con nanofibras

SUPERJET-DF



- Manometro / Presa pentapolare.
- Pressure switch / 5 Pins plug.
- Manomètre / Prise a 5 broches male.
- Manometer / 5-Poliger industriestecker.
- Manómetro / Enchufe pentapolar.



- cod. SUPERJET-FE
- Raccordo di ingresso.
 - Inlet connection.
 - Raccord d'entrée.
 - Übergangsstück saugseitig.
 - Cambio de sección de ingreso.

OPTIONAL

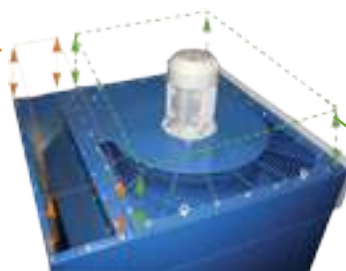

- cod. SUPERJET-FU
- Uscita dell'aria.
 - Air outlet.
 - Sortie d'air.
 - Ausblas.
 - Salida del aire.

- cod. PLUEMUN-INS
- Con rete.
 - With net.
 - Avec grille.
 - Mit schutzgitter.
 - Con red.

- cod. PLUEMUN-CA
- Con carboni attivi.
 - With activated carbons.
 - Avec charbons actif.
 - Mit aktivkohle.
 - On carbon activo.

- cod. PLUEMUN-FA
- Con filtro assoluto.
 - With hepa filter.
 - Avec filtre absolu.
 - Mit absolutfilter.
 - Con filtro absoluto.

PLENUM INSONORIZZATO



Sistema automatico di pulizia ad aria compressa - Pneumatic cleaning automatic system (with compressed air) - Système automatique de décolmattage a air comprimé - Einer automatische Druckluftabreinigung - Sistema de limpieza por medio de aire comprimido



SUPERJET-DF4



SUPERJET-DF6



SUPERJET-DF9

Dettagli tecnici - Technical details - Données techniques - Technische Daten - Datos Técnicos

Model	m ³ /h max	c.f.m.	%	m ²	Kg	Lbs	V	phases	CART	Hz	cert	HP	KW	db
SUPERJET-DF4	2200	1298	99,99	37	380	836	230/400	3P+N+T	4 (A)	50/ 60 on request	CE	3	2,2	78
SUPERJET-DF430	3000	1770	99,99	48	385	847	230/400	3P+N+T	4 (A)	50/ 60 on request	CE	4	3	78
SUPERJET-DF4 THERMALCUT-N	2000	1180	-	84	460	1012	230/400	3P+N+T	4 (C)	50/ 60 on request	CE	3	2,2	77
SUPERJET-DF4 THERMALCUT-M	2000	1180	-	48	460	1012	230/400	3P+N+T	4 (B)	50/ 60 on request	CE	3	2,2	77
SUPERJET-DF6	4000	2360	99,99	72	470	1034	400/690	3P+N+T	6 (A)	50/ 60 on request	CE	5,5	4	81
SUPERJET-DF6 THERMALCUT-N	2500	2360	-	84	550	1240	230/400	3P+N+T	4 (C)	50/ 60 on request	CE	4	3	75
SUPERJET-DF6 THERMALCUT-M	2500	2360	-	48	550	1240	230/400	3P+N+T	4 (B)	50/ 60 on request	CE	4	3	75
SUPERJET-DF9	6500	3835	99,99	108	620	1364	400/690	3P+N+T	9 (A)	50/ 60 on request	CE	10	7,5	85
SUPERJET-DF9 THERMALCUT-N	3500	3835	-	126	752	1654	400/690	3P+N+T	6 (C)	50/ 60 on request	CE	5,5	4	79
SUPERJET-DF9 THERMALCUT-M	3500	3835	-	72	752	1654	400/690	3P+N+T	6 (B)	50/ 60 on request	CE	5,5	4	79



SUPERJET-DF9PLUS



Il nuovo filtro a cartucce orizzontali SUPERJET-DF trova applicazione nell'aspirazione e filtrazione di fumi di saldatura, polveri grossolane e fini, trucioli in modesta quantità, polveri/fumi da taglio termico. Il gruppo è costituito da una precamera, dove la maggior parte delle polveri grossolane viene separata e si deposita nel primo cassetto di raccolta; il successivo labirinto e la sezione filtrante con cartucce ad alta efficienza provvedono alla filtrazione delle polveri residue. Il ventilatore ad alto rendimento, posto nella parte alta dell'unità, garantisce un'elevata capacità di aspirazione ed una bassa rumorosità.



The new SUPERJET-DF equipped with horizontal cartridges is suitable for suction and filtration of welding fumes, fine and coarse dusts as well as of small quantities of chips, dusts/fumes from thermal cutting. The filter unit consists of one pre chamber, where the most dusts are sorted out, falling then in the first collecting bin. The following labyrinth together with the high efficiency filtering cartridges and the second collecting bin complete the filtration of the remaining dusts. The high performance fan, placed just on the top of the unit, assures a high suction capacity and a low noise level.



Le nouveau filtre a cartouches horizontale SUPERJET-DF a été conçu pour l'aspiration et la filtration des fumées de soudure, poussières, de la plus fine à la plus grossière, certains types de copeaux en faible quantité, poussières et fumées de découpe laser. Le groupe est constitué d'une préchambre de décompression dans laquelle la majeure partie des polluants sont séparés et se déposent dans le premier caisson de récupération. La chicane qui suit et la partie filtration constituée de cartouches filtrantes à très haute efficacité permettent une filtration des poussières résiduelles. Le motoventilateur à haut rendement, positionné dans la partie haute du groupe, fonctionne en dépression, assure une grande capacité d'aspiration et un niveau sonore particulièrement faible.



Das neue Filtergerät mit horizontalen Filterpatronen SUPERJET-DF findet die optimale Anwendung bei der Absaugung und Filtration von Schweißrauch, feinen und groben Stäuben, kleine Mengen an Späne, sowie Stäube und Rauch aus Laser- und Plasmaschneiden. Das Gerät besteht aus einer Vorkammer, bei welcher die groben Stäube bereits abgeschieden werden und sich in den ersten Behälter auf sammeln; das nachstehende Labyrinth und die Filterkammer mit Hochleistungspatronen gewährleisten die Filtration der Reststäube. Der im oberen Teil des Gerätes angeordnete Ventilator garantiert eine hohe Saugleistung und einen niedrigen Lärmemission.



El nuevo filtro SUPERJET-DF con cartuchos horizontales, encuentra aplicación en la aspiración y filtración de humos de soldadura, polvos finos y gruesos en cantidades limitadas y polvos/humos procedentes de corte termico. El equipo está constituido por una pre cámara, donde se produce una primera pre-separación de la mayor parte de los polvos, que se depositan en el primer cajón de recolección. A seguir hay un laberinto y una sección de filtración con cartuchos de alta eficiencia donde se produce la filtración de los polvos residuos. Estos polvos residuos se depositan en el segundo cajón de recolección. El aire filtrado, atraviesa el ventilador de alto rendimiento, situado en la parte superior del filtro que garantiza una elevada capacidad de aspiración con un bajo nivel de ruido.

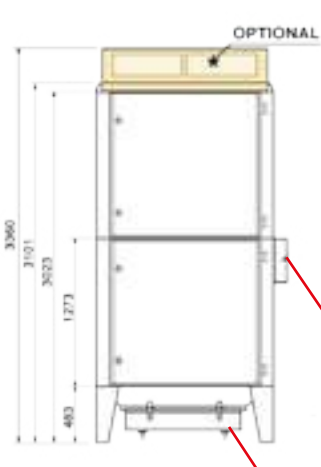

- Filtro assoluto OPTIONAL.
- HEPA filter OPTIONAL.
- Filtre absolu OPTIONAL.
- H13- Absolutfilter OPTIONAL.
- Filtro absoluto OPTIONAL.



- Gruppo predisposto per l'ingresso dell'aria sia sul lato destro sia sul lato sinistro.
- Air inlet right or left.
- Groupe prédisposé pour l'entrée de l'air aussi bien sur le coté droit que sur le coté gauche.
- Filtereintritt sowohl auf der linken Seite, als auch auf der rechten Seite.
- Opcion entrada aire lado derecho o izquierdo.



- Quadro elettrico.
- Electric control board.
- Armoire électrique.
- Schaltschrank.
- Tablero eléctrico.



Dimensioni (mm)
Dimensions (mm)
Dimensions (mm)
Abmessungen (mm)
Medidas (mm)

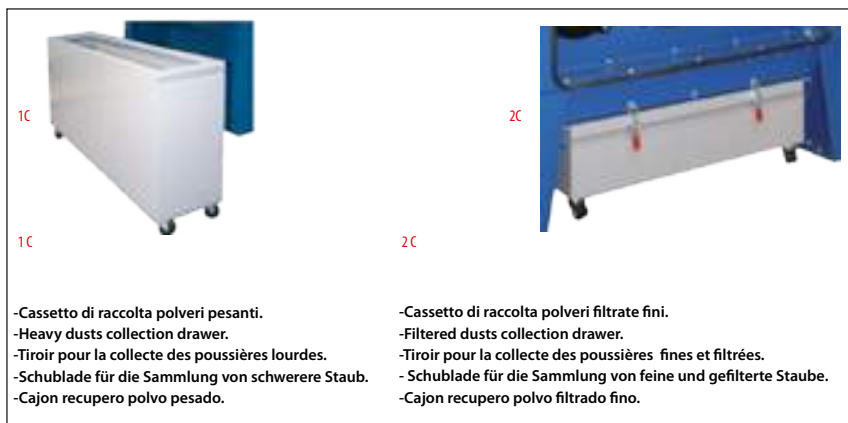
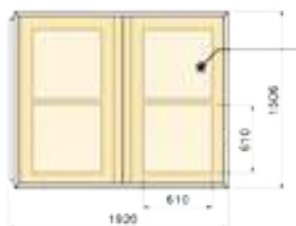

- Cassetto di raccolta polveri pesanti.
- Heavy dusts collection drawer.
- Tiroir pour la collecte des poussières lourdes.
- Schublade für die Sammlung von schwerere Staub.
- Cajon recupero polvo pesado.

- Cassetto di raccolta polveri filtrate fini.
- Filtered dusts collection drawer.
- Tiroir pour la collecte des poussières fines et filtrées.
- Schublade für die Sammlung von feine und gefilterte Staube.
- Cajon recupero polvo filtrado fino.

SUPERJET-DF9PLUS



filtration process

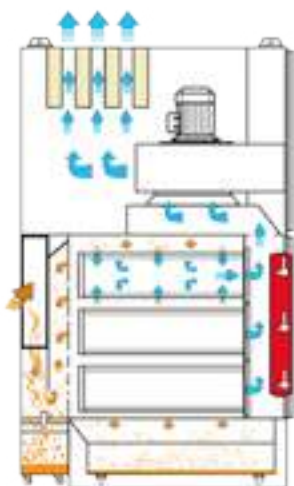

 **ARIA INQUINATA**
 AIR POLLUTED
 POLLUËTE AIR
 SCHMUTZLUFT
 AIRE CONTAMINADO

 **ARIA FILTRATA**
 AIR FILTERED
 CLEAN AIR
 REINLUFT
 AIRE FILTRADO

 **ARIA COMPRESSA**
 AIR COMPRESSOR
 COMPRESSED AIR
 DRUCKLUFT
 AIRE COMPRIMIDO



M PES

cod. SUPERJET-DF-PLUS-CART/MPES
 Ø325 - H1200 mm
 Cartuccia in Poliestere.
 -Polyester cartridges.
 -Cartouches Polyester.
 -Filterpatronen.
 -Cartuchos filtrantes.

NANOTECH

cod. SUPERJET-DF-PLUS-CART/NANOTECH
 Ø325 - H1200 mm
 -Cellulosa con nanofibers
 -Cellulose with nanofibres
 -Cellulose avec nanofibres
 -Zellulose mit nanofaser
 -Celulosa con nanofibras



cod. SUPERJET-FE
 -Raccordo di ingresso.
 -Inlet connection.
 -Raccord d'entrée.
 -Übergangsstück saugseitig.
 -Cambio de sección de ingreso.



cod. SUPERJET-FU
 -Uscita dell'aria.
 -Air outlet.
 -Sortie d'air.
 -Ausblas.
 -Salida del aire.

Ø INLET/OUTLET ON REQUEST

MEMBRANE

cod. SUPERJET-DF-PLUS-CART/ME-MEMBRANE
 Ø325 - H1200 mm
 -Membrana teflon
 -Teflon membrane
 -Membrane de teflon
 -Membran
 -Membrane de teflon

Sistema automatico di pulizia ad aria compressa - Pneumatic cleaning automatic system (with compressed air)
 - Système automatique de décolmattage a air comprimé - Einer automatischen Druckluftabreinigung - Sistema de limpieza por medio de aire comprimido

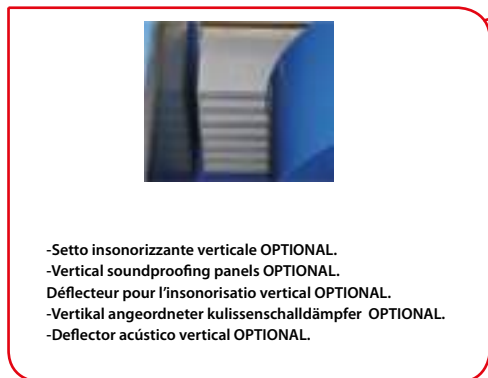

SUPERJET-DF9PLUS

Dettagli tecnici - Technical details - Données techniques - Technische Daten - Datos Técnicos

Model	m ³ /h max	c.f.m.	%	m ²	Kg	Lbs	V	phases	CART	Hz	cert	HP	KW
SUPERJET-DF9PLUS11	8000	4710	99,99	189	1450	3190	400	3P+N+T	9	50	CE	15	11
SUPERJET-DF9PLUS15	11000	6490	99,99	189	1500	3300	400	3P+N+T	9	50	CE	20	15



SYSTEM CENTRALIZED SUPERJET

SUPERJET-DF4

	20 mt Tot (compreso Camino espulsione)	1/2 Contemporaneità
	20 mt Tot (including Chimney expulsion)	1/2 Contemporary
	20 mt Tot (y compris l'expulsion Cheminée)	1/2 Contemporaine
	20 mt Tot (wozu auch die Ausweisung Kamin)	1/2 Zeitgenössischen
	20 mt Tot (incluyendo la expulsión Chimenea)	1/2 Contemporaneidad

SUPERJET-DF4R

	20/30 mt Tot (compreso Camino espulsione)	2/3 Contemporaneità
	20/30 mt Tot (including Chimney expulsion)	2/3 Contemporary
	20/30 mt Tot (y compris l'expulsion Cheminée)	2/3 Contemporaine
	20/30 mt Tot (wozu auch die Ausweisung Kamin)	2/3 Zeitgenössischen
	20/30 mt Tot (incluyendo la expulsión Chimenea)	2/3 Contemporaneidad

SUPERJET-DF6

	30/35 mt Tot (compreso Camino espulsione)	3/3 Contemporaneità
	30/35 mt Tot (including Chimney expulsion)	3/3 Contemporary
	30/35 mt Tot (y compris l'expulsion Cheminée)	3/3 Contemporaine
	30/35 mt Tot (wozu auch die Ausweisung Kamin)	3/3 Zeitgenössischen
	30/35 mt Tot (incluyendo la expulsión Chimenea)	3/3 Contemporaneidad

SYSTEM CENTRALIZED SUPERJET



SUPERJET-DF9

	40/45 mt Tot (compreso Camino espulsione)	4/4 Contemporaneità
	40/45 mt Tot (including Chimney expulsion)	4/4 Contemporary
	40/45 mt Tot (y compris l'expulsion Cheminée)	4/4 Contemporaine
	40/45 mt Tot (wozu auch die Ausweisung Kamin)	4/4 Zeitgenössischen
	40/45 mt Tot (incluyendo la expulsión Chimenea)	4/4 Contemporaneidad

SUPERJET-DF9PLUS11

	50/60 mt Tot (compreso Camino espulsione)	5/6 Contemporaneità
	50/60 mt Tot (including Chimney expulsion)	5/6 Contemporary
	50/60 mt Tot (y compris l'expulsion Cheminée)	5/6 Contemporaine
	50/60 mt Tot (wozu auch die Ausweisung Kamin)	5/6 Zeitgenössischen
	50/60 mt Tot (incluyendo la expulsión Chimenea)	5/6 Contemporaneidad

SUPERJET-DF9PLUS15

	60/70 mt Tot (compreso Camino espulsione)	6/7 Contemporaneità
	60/70 mt Tot (including Chimney expulsion)	6/7 Contemporary
	60/70 mt Tot (y compris l'expulsion Cheminée)	6/7 Contemporaine
	60/70 mt Tot (wozu auch die Ausweisung Kamin)	6/7 Zeitgenössischen
	60/70 mt Tot (incluyendo la expulsión Chimenea)	6/7 Contemporaneidad



Unità filtrante ad azione meccanica per abbattimento fumi di saldatura. Equipaggiato con prefiltro metallico antiscintilla, 2 celle filtranti in poliestere ad efficienza crescente e cella di carboni attivi per deodorare i fumi filtrati. Ideale per impianti con reintegro fumi in ambiente di lavoro, STARFILTER è disponibile in 2 modelli da 2.000 e 4.000 m³/h.



Mechanical Filtering unit for cleaning welding fumes. Equipped with metallic anti-spark pre-filter, 2 incremental efficiency polyester filtering cells and an activated carbon cell for deodorising filtered fumes. Ideal for systems where fumes are recycled into the working area, STARFILTER is available in two models: 2.000 and 4.000 m³/h.



Unité mécanique pour la filtration des fumées de soudure. Équipé d'un préfiltre métallique anti-étincelles, de 2 cellules filtrantes en polyester à efficacité progressive et de cellule à charbons actifs pour désodoriser les fumées filtrées. Idéal pour installations à recyclage des fumées en atmosphère de travail, STARFILTER existe en 2 modèles de 2.000 et 4.000 m³/h.



Mechanische wirkender Filtereinheit für das Abscheiden von Schweißrauch. Ausgestattet mit Funkenlöcher-Vorfilter aus Metall, 2 Filterzellen aus progressiv aufgebautem Polyester und einer Aktivkohlezelle zur Geruchsverbesserung der gefilterten Rauche. Ideal für Anlagen, bei denen der Rauch in die Arbeitsumgebung zurückgeführt wird. STARFILTER ist in 2 Modellen - 2.000 und 4.000 m³/h - erhältlich.



Maquinas filtrantes fijas con filtro ad accion mecanica para eliminar los humos de soldadura. Equipado con prefiltro metálico antichispa, 2 cámaras filtrantes de poliéster de eficacia creciente y cámara de carbón activo para desodorizar los humos filtrados. Ideal para sistemas con evacuación de humos en el ambiente de trabajo. STARFILTER está disponible en 2 modelos de 2.000 y 4.000 m³/h.

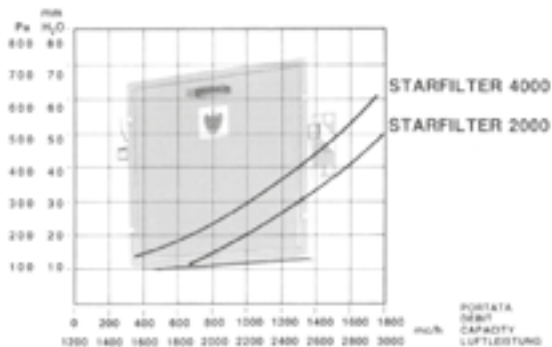

STARFILTER

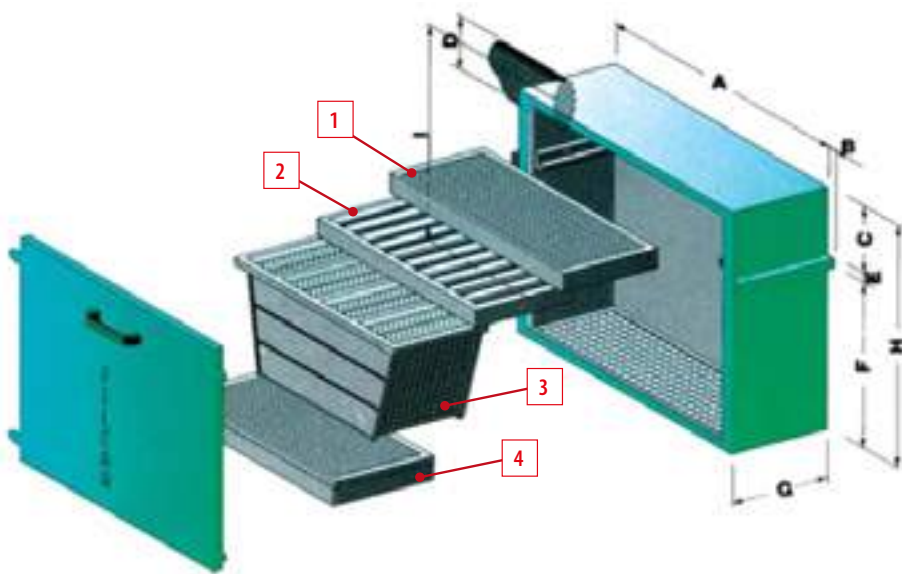

- 1 FIREFILTER**
(cod. STAR2000-RIPM)
(cod. STAR4000-RIPM)
- 2 PREFILTER**
(cod. STAR2000-RIPS)
(cod. STAR4000-RIPS)
- 3 SMOKEFILTER**
(cod. STAR-2000-RIF)
(cod. STAR-4000-RIF)
- 4 CARBONFILTER**
(cod. STAR2000-CONT)
(cod. STAR4000-CONT)

A	B	C	D	E	F	G	H	I
700	45	320	200	55	445	310	820	690
700	45	320	200	55	445	610	820	690

Accessori - Accessories - Accessoires - Zubehör - Accesorios



STAR-2000-SPS / STAR-4000-SPS

Kit composto da 2 supporti per fissaggio a muro.

Kit consisting of 2 wall supports.

Kit composé de 2 supports pour fixation murale.

Kit bestehend aus 2 Halterungen für die Wandbefestigung.

Kit con 2 soportes de pared.

STAR-2000-FU / STAR-4000-FU

Flangia di collegamento tra filtro e camino di espulsione fumi Ø 200R.

Connecting flange between filter and exhaust Ø 200R.

Bride de raccordement entre le filtre et le cheminée d'expulsion avec Ø 200R.

Anschlussflansch zwischen dem Filter und der Verteilung Kamin mit Ø 200R.

Brida de acople entre el filtro y la chimenea de expulsion humos con Ø 200R.

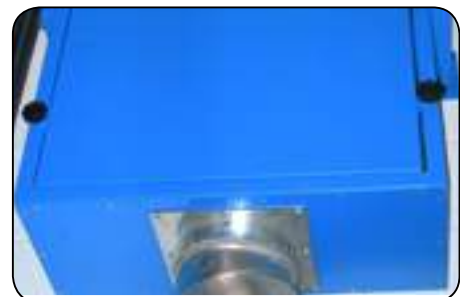

Dettagli tecnici - Technical details - Données techniques - Technische Daten - Datos Técnicos

Model	m ³ /h	c.f.m.	mm H ₂ O	Pa	%	Kg	Lbs	Carb. Kg	Carb. Lbs
STARFILTER-2000	2000	1176	75	750	95	55	121	8	17,6
STARFILTER-4000	4000	2352	85	850	95	90	199	16	35,2



 Filtro modulare a tasche di poliestere per la filtrazione di fumi di saldatura. La combinazione del modello FILTER con il modello CARBON permette di filtrazione e deodorare dei fumi su impianti con portate fino a 27.000 m³/h.

 Modular polyester pocket filter for filtering welding fumes. The combination of the FILTER and CARBON models can be used to filter and deodorise fumes in systems with a capacity of up to 27.000 m³/h.

 Filtre modulaire à poches en polyester pour filtration de fumées de soudure. La combinaison du modèle FILTER au modèle CARBON permet de filtrer et de désodoriser des fumées sur des installations à des débits jusqu'à 27.000 m³/h.

 Modularer Polyester-Taschenfilter für das Filtern von Schweißrauch. Die Kombination des Modells FILTER mit dem Modell CARBON ermöglicht das Filtern und die Geruchsverbesserung von Rauchen an Anlagen mit Leistung bis 27.000 m³/h.

 Filtro modular de compartimentos en poliéster para filtrar humos de soldadura. Combinando los modelos FILTER y CARBON es posible filtrar y desodorizar los humos de sistemas con caudales de hasta 27.000 m³/h.



N	Model
1	FILTER
2	CARBON
3	FEU*
4	ME-750-1000

* Scegliere il Ø di uscita
 * Choose the outlet diam.
 * Choisir le Ø de sortie
 * Bitte Ausblas DN wählen
 * Indicar diámetro de salida

FILTER-CARBON



FILTER

CARBON

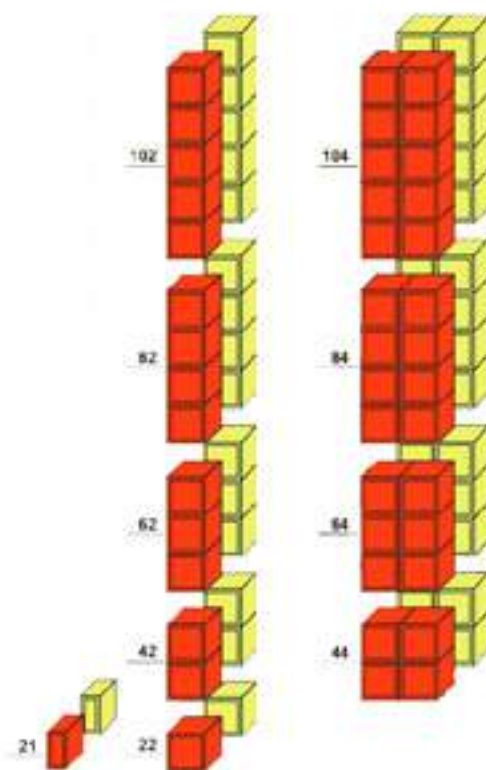
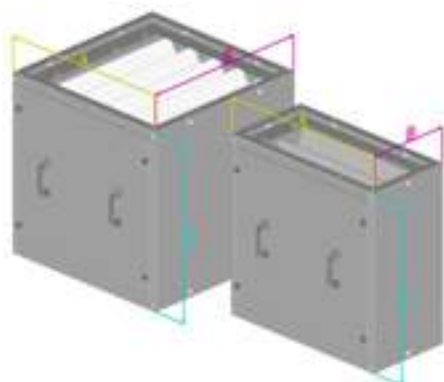

Dettagli tecnici - Technical details - Données techniques - Technishe Daten - Datos Técnicos

FILTER	m ³ /h	c.f.m.	Tot Kg	Lbs	A	B	C	Ricambi - Spare parts - Pièces détachées - Ersatzteile - Refacciones	Cod.
FILTER-21	1500	882	25	55	700	350	700		1 x PF-287 - 1 x FIT-287
FILTER-22	3000	1764	42	92	700	700	700		1 x PF-590 - 1 x FIT-590
FILTER-42	6000	3529	84	185	1400	700	700		2 x PF-590 - 2 x FIT-590
FILTER-44	12000	7058	168	370	1400	1400	700		4 x PF-590 - 4 x FIT-590
FILTER-62	9000	5292	126	277	2100	700	700		3 x PF-590 - 3 x FIT-590
FILTER-64	18000	10588	252	554,4	2100	1400	700		6 x PF-590 - 6 x FIT-590

Cod. FILTRI
PF-287 PREFILTER 700 x 350
PF-590 PREFILTER 700 x 700
FIT-287 FILTER 700 x 350
FIT-590 FILTER 700 x 700

FILTER



95% FILTRATION EFFICIENCY

CARBON	Carb. Kg	Tot Kg	Tot. Lbs	A	B	C	Ricambi - Spare parts - Pièces détachées - Ersatzteile - Refacciones	Cod.
CARBON-21	20	48	105	700	350	700		2 x CARBON-RIS 10 Kg
CARBON-22	40	88	194	700	700	700		4 x CARBON-RIS 10 Kg
CARBON-42	80	176	387	1400	700	700		8 x CARBON-RIS 10 Kg
CARBON-44	160	352	775	1400	1400	700		16 x CARBON-RIS 10 Kg
CARBON-62	120	264	509	2100	700	700		12 x CARBON-RIS 10 Kg
CARBON-64	240	528	1162	2100	1400	700		24 x CARBON-RIS 10 Kg

Cod. CARTUCCIA
CARBON-CARTU
CARBON-RIS 10 Kg

CARBON







 Filtro modulare a cartucce (IFA - BIA - M PES) per la depurazione di fumi e polveri derivanti da processi di saldatura o taglio. Studiato per impianti centralizzati anche di portata elevata dispone di sistema di pulizia automatica ad aria compressa per mezzo di programmatore ciclico con depressostato differenziale. Portata max 31.000 m³/h.

 Modular cartridge filter (IFA - BIA - M PES category) suitable for the extraction and filtration of fumes and dusts produced by welding and cutting procedures. It is suitable for centralized systems requiring high airflows. It is equipped with automatic and pneumatic cyclic cleaning programmer with differential pressure gauge. Max airflow 31.000 m³/h.

 Filtre modulaire à cartouches (IFA - BIA - M PES) pour le dépolluissage des fumées et poussières dérivantes de procédés de soudage ou de coupage. Étudié pour des installations centralisées même à des débits élevés, le filtre dispose d'un système de décolmatage par jet d'air comprimé programmable avec pressostat différentiel. Débit maximum: 31.000 m³/h.

 Modulpatronenfilter (IFA - BIA - M PES) fuer Rauch- und Staubreinigung; bestimmt fuer Rauch und Staub, die von Schweiß- Schnit Sarbeit verursacht sind. Fuer zentralisierte- mit Hochfoerderleistungsanlage geplant, mit Druckluftautomatischesreinigungssystem der durch ein zyklische Programm mit differenzial Druckschalter funktioniert. Maximale Leistung bis 31.000 m³/St.

 Unidad filtro-aspirante con cartucho (IFA - BIA - M PES) para la depuración de humo y polvo producidos durante procesos de soldadura y corte. Desarrollado para instalaciones centralizadas también de grandes caudales, lleva un sistema de limpieza automática con aire comprimido por medio de un programador cíclico con depressostato diferencial. Caudal max 31.000 m³/h.

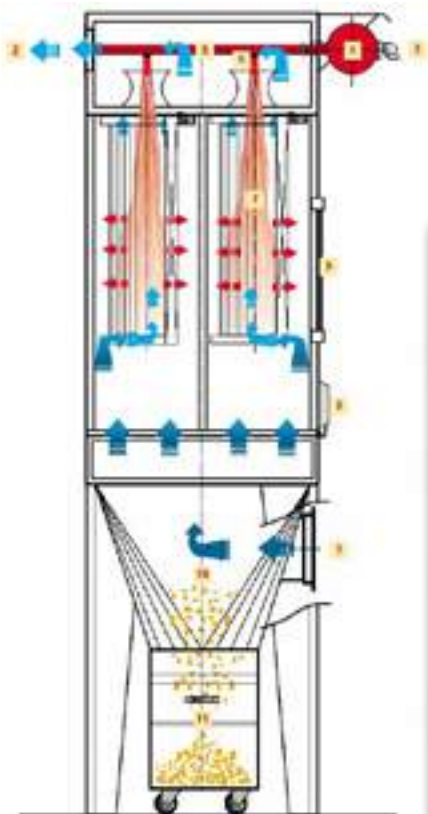
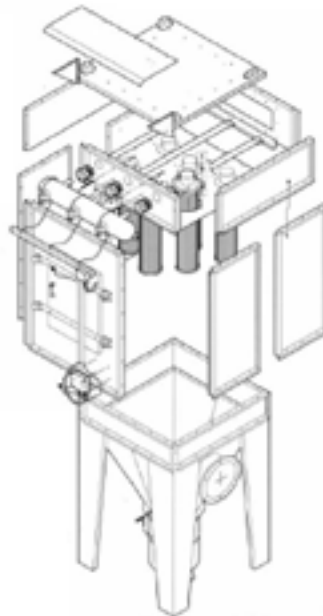

FILTERJET-30/40/60/80

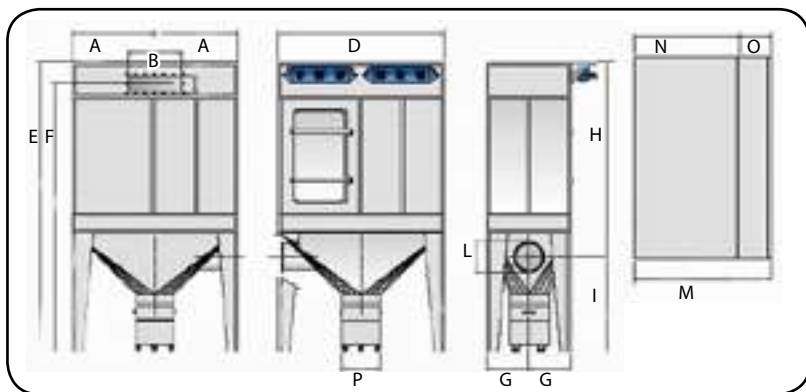

FILTERJET-90

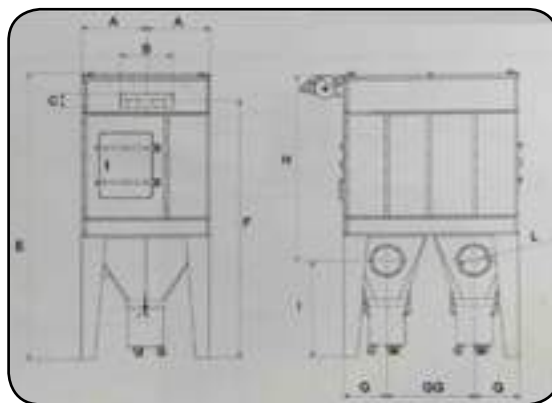

FILTERJET-120/210

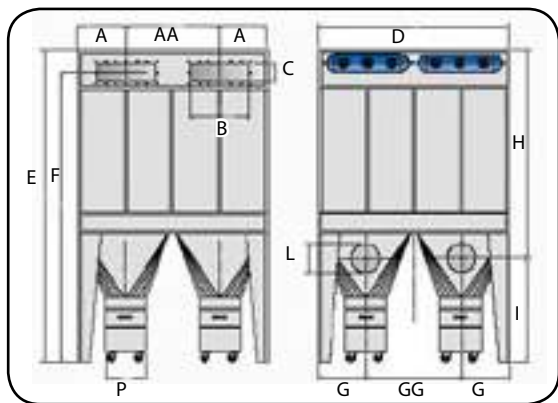

FILTERJET-310

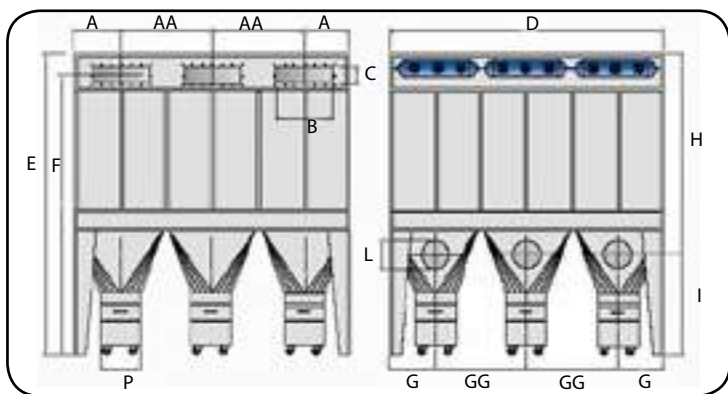

cod. SUPERJET-FE

- Raccordo di ingresso.
- Inlet connection.
- Raccord d'entrée.
- Übergangsstück saugseitig.
- Cambio de sección de ingreso.

cod. SUPERJET-FU

- Uscita dell'aria.
- Air outlet.
- Sortie d'air.
- Ausblas.
- Salida del aire.

Ø INLET/OUTLET ON REQUEST



- Pulizia automatica
- Automatic Cleaning
- Décolmatage Automatique
- Automatischesreinigungssystem
- Limpieza Automática



cod. FILTERJET/C07 - Ø325X175X700
IFA -BGIA-M-PES

cod. FILTERJET/C10 - Ø325X175X1000
IFA -BGIA-M-PES

Dettagli tecnici - Technical details - Données techniques - Technische Daten - Datos Técnicos

Model	A	AA	B	C	D	E	F	G	GG	H	I	L	M	N	O	P	m ³ /h	N. Cart	Ø CART	m ²	Kg	Lbs
FILTERJET-30	575	-	700	200	1150	3515	3170	575	-	2145	1370	400	1550	1150	400	500	3600	6	Ø325x700	65	450	990
FILTERJET-40	575	-	700	200	1150	4015	3670	575	-	2645	1370	400	1550	1150	400	500	5200	6	Ø325x1000	94	580	1276
FILTERJET-60	850	-	700	200	1700	4015	3670	575	-	2615	1400	400	1550	1150	400	500	6900	8	Ø325x1000	125	840	1848
FILTERJET-80	1150	-	700	200	2300	4015	3670	575	-	2615	1400	400	1550	1150	400	500	10300	12	Ø325x1000	188	1100	2420
FILTERJET-90	820	-	700	200	2300	4015	3670	570	1160	2615	1400	400	2100	1700	400	500	13500	16	Ø325x1000	250	1650	3630
FILTERJET-120	630	1100	700	200	3460	4015	3670	570	1160	2645	1370	400	1550	1150	400	500	15500	18	Ø325x1000	282	1820	4004
FILTERJET-210	600	1100	700	200	2300	4015	3670	570	1160	2615	1400	400	2700	2300	400	500	20700	24	Ø325x1000	376	2200	4840
FILTERJET-310	630	1100	700	200	3460	4015	3670	570	1160	2615	1400	400	2700	2300	400	500	31000	36	Ø325x1000	564	3200	7040



Gruppo filtro-aspirante per nebbie oleose completo di elettroaspiratore. Grazie alla forza centrifuga del prefiltro elicoidale viene separata la quasi totalità delle particelle oleose. Per eliminare eventuali impurità residue l'aria passa attraverso un filtro a tasche a grande superficie filtrante. Portata max 3.600 m³/h. Disponibile in versione carrellata con 1 bracci Ø150 L 3 mt o fisso per impianti centralizzati OIL-GAMM-2M.



Filtering unit equipped with fan for oil mists. The biggest part of the oil particles are separated thanks to centrifugal effect of the helical prefilter. The possible remaining impurities in the air are collected by a pocket filter with wide filtering surface. Max airflow 3.600 m³/h. Available as trolley version with one arm Ø150 L 3 mt or stationary as centralized projects OIL-GAMM-2M.



Groupe aspirant et filtrant pour brouillard d'huile. Grâce au ventilateur et à la force centrifuge dans le préfiltre, les particules huileuses sont séparées de l'air. Les impuretés restantes sont filtrées à travers un filtre à poche et les substances liquides sont récupérées dans un récipient, Débit d'aspiration maximum : 3.600 m³/h. Disponible dans la version avec chariot et 1 bras Ø150 de 3 mt. ou dans la version fixe pour systèmes centralisés OIL-GAMM-2M.



Filter und Absaugungseinheit fuer Oelnebel ausgestattet mit Ventilator. Dank der Zentrifugalkraft der Spiralvorfilter werden fast alle Oelpartikeln getrennt. Um eventuelle Unreinheiten zu vermeiden, dann wird das Luft durch ein Taschenfilter mit hoehe Filterflaeche filtriert. Foerderleistungen 3.600 M³/St. Erhältlich in der Rädern Version mit ein Arme Ø150 von 3 mt., oder in der feste Version fuer zentralisierte Systeme OIL-GAMM-2M.



Grupo filtro-aspirante para neblina de aceite completo de electroaspirador. Gracias a la fuerza centrifuga del prefiltro elicoidal, se separa casi la totalidad de las partículas aceitosas. Para eliminar eventuales impurezas residuales, el aire pasa a través de un filtro a bandeja con grande superficie filtrante. Caudal max 3.600 m³/h. Disponible en version sobre ruedas con 1 brazo Ø150 L 3 mt o fijo para estructuras centralizadas OIL-GAMM-2M.

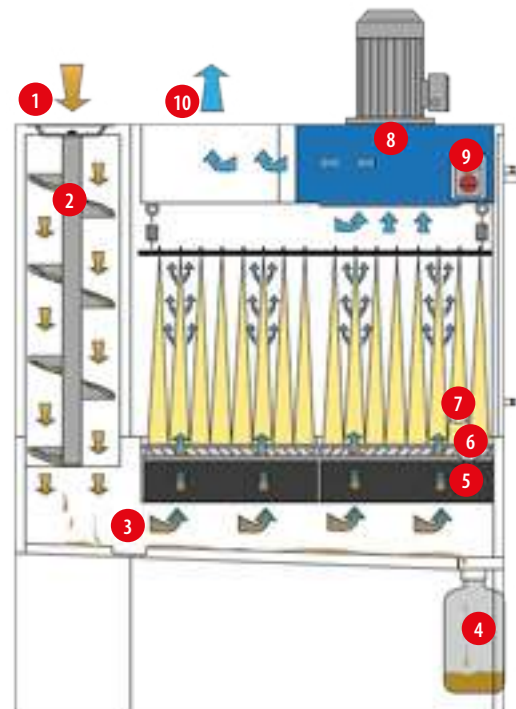
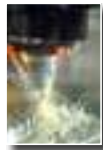

- 1 ENTRATA NEBBIE OLEOSE - OIL MIST AIR INLET - ARRIVÉE DES BROUILLARDS D'HUILE - SAUGUNG ÖLNEBEL - ENTRADA NUBES ACEITOSAS
- 2 SEPARATORE CENTRIFUGO - CENTRIFUGAL SEPARATOR - SÉPARATEUR CENTRIFUGE - ZENTRIFUGALSEPARATOR - SEPARADOR CENTRÍFUGO
- 3 TRAMOGGIA SCARICO OLIO - OIL DRAIN HOPPER - TRÉMIE D'ÉVACUATION DE L'HUILE - ÖLABLASS-TRICHTER - TOLVA DESCARGA DE ACEITE
- 4 BIDONE DI RACCOLTA OLIO - OIL COLLECTING TANK - BIDON DE RÉCUPÉRATION D'HUILE - SAMMELBEHÄLTER - BIDON DE RECOLECCIÓN DE ACEITE
- 5 SEPARATORE DI GOCC - DROP SEPARATOR - SÉPARATEUR DE GOUTTES - TROPFENABSCHIEDER - SEPARADOR DE GOTAS (OPTIONAL)
- 6 PREFILTRO IN PAGLIA METALLICA - WIRE METAL MESH PREFILTER - PRÉFILTRE EN PAILLE MÉTALLIQUE - VORFILTER AUS METALLSTROH - PREFILTRO EN PAJA METÁLICA
- 7 FILTRO A TASCHE - FILTRE À POCHE - POCKET FILTER - TASCHENFILTER - FILTRO DE BOLSILLOS
- 8 VENTILATORE - FAN - VENTILATEUR - VENTILATOR - VENTILADOR
- 9 INTERRUPTORE TERMICO A NORME CE - CE RULES THERMAL SWITCH - INTERRUPTEUR AUX NORMES CE - EIN/AUS SCHALTER - INTERRUPTOR TÉRMICO DE ACUERDO CON LAS NORMAS CE
- 10 USCITA ARIA FILTRATA - CLEAN AIR OUTLET - SORTIE D'AIR FILTRÉE - REINLUFT-AUSBLASSEITE - SALIDA AIRE FILTRADO

OIL-GAMM



OPTIONAL



- cod.
 -Separatore di gocce
 -Drop separator
 -Séparateur de gouttes
 -Tropfenabscheider
 -Separador de gotas



- cod.
 -Sifone per scarico
 -Siphon for discharge
 -Siphon pour évacuation
 -Syphon zum austrag
 -Sifón de descarga



- cod.
 -Pressostato differenziale con contatto pulito per segnalazione intasamento filtro su quadro elettrico
 -Pressure switch for filter clogging alarm on control board
 -Pressostat différentiel avec contact sec pour indication de l'encrassement des filtres, sur l'armoire électrique
 -Differenzdruckmesser mit potentialfreien ausgang zur filter-sättigungsanzeige am schaltschrank
 -Presostato diferencial completo de con-tacto limpio para la señalización de suciedad del filtro en el tablero eléctrico



- cod.
 -Raccordo d'ingresso
 -Inlet connection
 -Raccord d'entree
 -Übergangsstück saugseitig
 -Cambio de sección de ingreso

CODE	A mm	B mm
OIL-GAMM-1	1892	1022
OIL-GAMM-2	1936	1022
OIL-GAMM-4	1970	1412
OIL-GAMM-2M	1936	1022

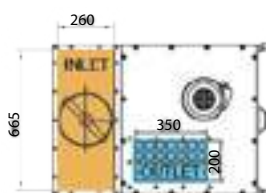
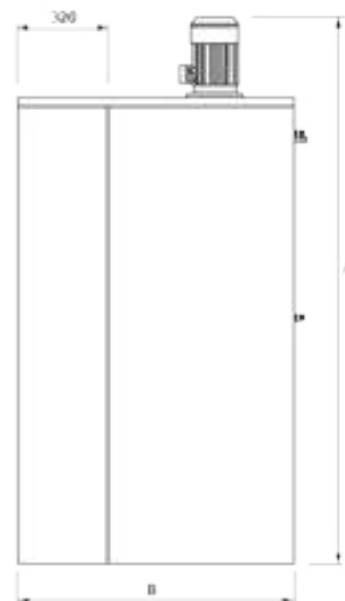

OIL-GAMM-1

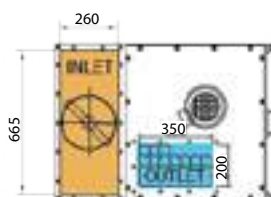

OIL-GAMM-2/2M

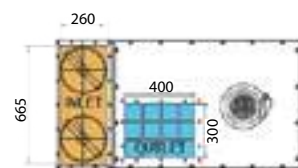

OIL-GAMM-4

Dettagli tecnici - Technical details - Données techniques - Technische Daten - Datos Técnicos

Model	Kg	Lbs	HP	kW	R.P.M	dBA	V*	Hz	m ³ /h	c.f.m.	%	l	inlet Ø mm	outlet
OIL-GAMM-1	160	352	1	0,75	2800	74	230/400*	3 Ph 50 Hz	1315	776	99	5	on request	
OIL-GAMM-2	192	424	2	1,5	2800	76	230/400*	3 Ph 50 Hz	2530	1493	99	5		
OIL-GAMM-4	245	540	4	3	2800	83	230/400*	3 Ph 50 Hz	3600	2124	99	5		
OIL-GAMM-2M	192	424	2	1,5	2800	76	230/400*	3 Ph 50 Hz	2530	1493	99	5		

* DISPONIBILE ANCHE MONOFASE 230V - MONOPHASE 230V VERSION AVAILABLE - DISPONIBLE EGALEMENT EN MONOPHASE 230V - AUCH EINFASIG VERFÜGBAR 230V - TAMBIÉN DISPONIBLE MONOFÁSICO 230 VOLTIOS

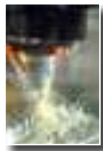

Il gruppo filtrante NOIL è stato concepito per purificare l'aria negli ambienti di lavoro ove si producono nebbie oleose e per recuperare l'olio consentendone il riciclo. Grazie all'impiego di un prefiltra in cellulosa e di un filtro in poliestere testati BIA USG, C, viene garantito un alto rendimento di captazione delle particelle oleose, il cui valore medio è pari al 98%. L'aria purificata viene quindi riciclata nell'ambiente di lavoro.



The NOIL filter unit has been made to purify the air in working premises, where oily fumes are produced and to recover the oil allowing the recycle of it. Thanks to the joint use of a BIA tested USG, C rated cellulose prefilter and polyester filter an high efficiency up to an average value of 98% in the capture of oil particles is guaranteed. The filtered air is then recycled in the work premises.



Le groupe NOIL a été conçu pour purifier l'air dans les milieux de travail où l'on produit des brouillards d'huile et permet la récupération de l'huile filtrée. Grâce à l'utilisation d'un filtre en cellulose et d'un filtre en polyester testés BIA USG, C on garanti une excellente captation des particules huileuses, dont la valeur moyenne est de 98%. On recycle par conséquent l'air purifié dans la zone de travail.



Das neue filtergerät wird in den räumen eingebaut, wo öl- und emulsionsnebel verursacht werden, um die luft zu reinigen und das gefilterte öl zurückzuerhalten. Die Anwendung eines besonderen Vorfilters aus zellulose und einer Polyester-Filterpatrone (Filterklasse BIA USG, C) garantiert einen durchschnittlichen Abscheidegrad vom 98%. Die gereinigte Luft wird danach im den Arbeitsraum rückgeführt.



El grupo de filtración NOIL ha sido creado tanto para purificar el aire en los ambientes de trabajo donde se producen nieblas oleosas como para recuperar el aceite filtrado permitiendo su reciclado. Gracias al uso de un pre-filtro de celulosa y de un filtro de poliéster, se garantiza un alto rendimiento de captación de las partículas oleosas, cuyo valor medio es equivalente al 98%. El aire purificado por consiguiente vuelve al ambiente de trabajo.

ARIA INQUINATA - POLLUTED AIR - AIR POLLUÉ
- KONTAMINIERTE LUFT - AIRE CONTAMINADO

OLIO - OIL - HUILE - ÖL - ACEITE

ARIA FILTRATA - CLEAN AIR - AIR FILTRÉ
- REINLUFT - AIRE FILTRADO



- 1 ENTRATA NEBBIE OLEOSE - OIL MIST AIR INLET - ARRIVÉE DES BROUILLARDS D'HUILE - SAUGUNG ÖLNEBEL - ENTRADA NUBES ACEITOSAS
- 2 VENTOLA - IMPELLER - TURBINE - LAUFRAD - TURBINA
- 3 CARTUCCIA FILTRANTE - FILTER CARTRIDGE - CARTOUCHE FILTRATE - FILTERPATRONE - CARTUCHO FILTRANTE
- 4 MOTORE ELETTRICO - ELETTRIC MOTOR - MOTEUR ELETRIQUE - MOTOR - MOTOR ELECTRICO
- 5 STAFFA SUPPORTO CARTUCCIA - CARTRIDGE HOLDING BRACKET - BRIDE SUPPORT CARTOUCHE - HALTERUNG PATRONE - SOSTEN DE CARTUCHO
- 6 SCARICO OLIO - OIL OUTLET - EVACUATION DE L'HUILE - ÖLABLAß - DESCARGA DE ACEITE
- 7 USCITA ARIA FILTRATA - CLEAN AIR OUTLET - SORTIE D'AIR FILTRÉ - AUSBLAS REINLUFT - SALIDA AIRE FILTRADO

ESEMPI DI INSTALLAZIONI - INSTALLATION EXAMPLE - EXEMPLE D'INSTALLATION - EINSATZBEISPIELE - EJEMPLOS DE INSTALACIONES



cod. NOIL-CAV



cod. NOIL-MENS



A) Installazione del gruppo NOIL su cavalletto.
A) Stand support installation
A) Installation du groupe NOIL sur un chevalet
A) Aufstellung des NOIL auf einem Halter.
A) Instalación sobre cavallette

B) Installazione pensile.
B) Installation on a wall mounted bracket
B) Installation murale
B) Aufstellung des NOIL auf Konsole. Ölentleerung in Plastik-Tank
B) Instalación colgante

C) Installazione su supporto a colonna con scarico olio in vasca
C) Installation on a column support
C) Installation sur support à colonne
C) Ölentleerung in die Sammelwanne
C) Instalación con soporte a columna

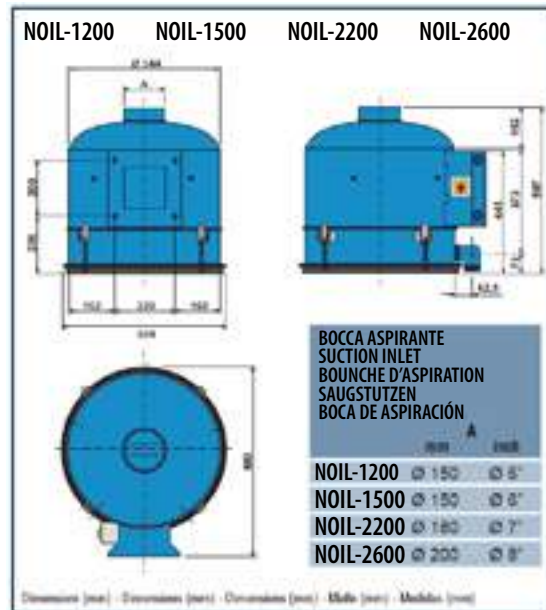
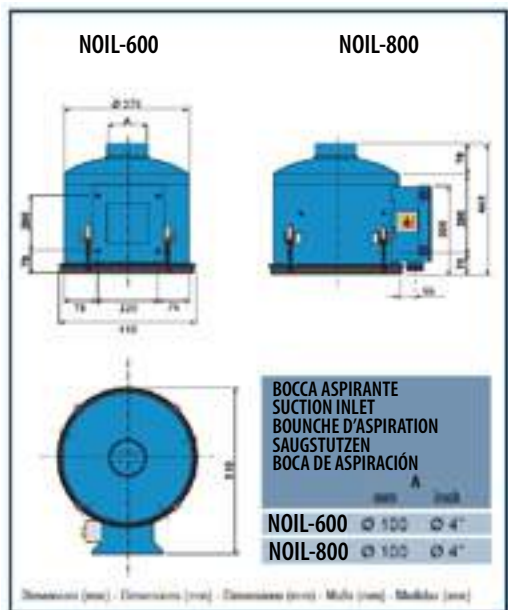

Accessori - Accessories - Accessoires - Zubehör - Accesorios



cod. NOIL-1-CA/POL - NOIL-2-CA-POL
IFA/BGIA M-PES
-Cartuccia in poliestere
-Polyester cartridge
-Cartouche filtrante en polyéster
-Patronenfilter aus Polyester
-Cartucho en poliester

cod. NOIL-1-CA/CEL - NOIL-2-CA-CEL
IFA/BGIA M-CEL
-Cartuccia in cellulosa
-Cellulose filter cartridge
-Cartouche filtrante en cellulose
-Patronenfilter aus Zellulose
-Cartucho de celulosa

-Cartuccia in poliestere
-Polyester cartridge
-Cartouche filtrante en polyester
-Filterpatrone aus polyester
-Cartucho en poliester



Dettagli tecnici - Technical details - Données techniques - Technische Daten - Datos Técnicos

Model	Kg	Lbs	HP	kW	Hz	R.P.M	dBA	V	m ³ /h	c.f.m.	mmH ₂ O	inlet Ø mm
NOIL-600	28	62	1	0,75	50	2900	68	230/400	600	350	50	100
NOIL-800	29	64	1	0,75	50	2900	72	230/400	800	470	50	100
NOIL-1200	55	122	2	1,5	50	2900	74	230/400	1200	700	50	150
NOIL-1500	56	124	2	1,5	50	2900	75	230/400	1500	880	50	150
NOIL-2200	55	122	2	1,5	50	2900	75	230/400	2200	1290	50	180
NOIL-2600	56	124	2	1,5	50	2900	76	230/400	2600	1530	50	200

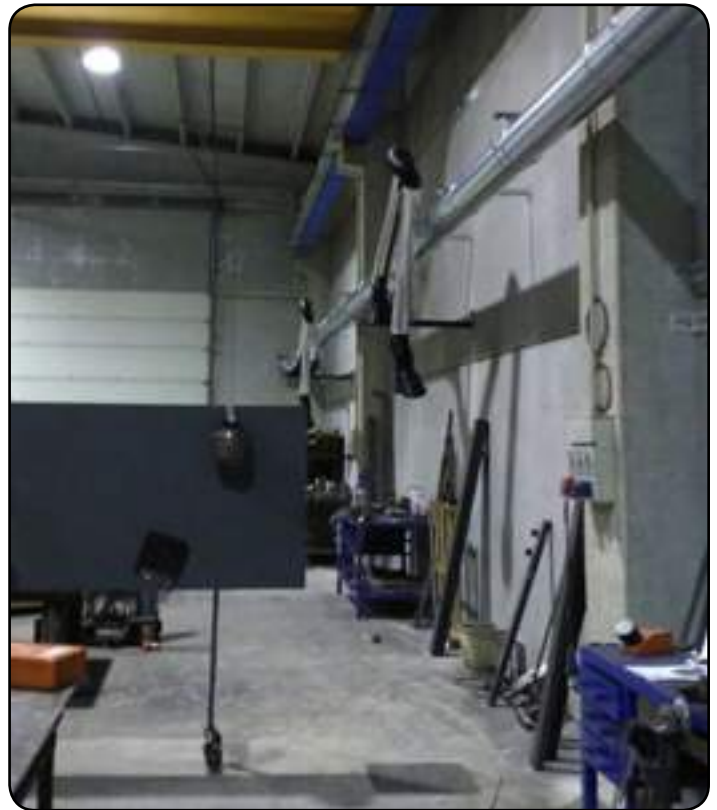

www.filcar.eu

BANCHI ASPIRANTI



EXHAUST BENCHES
TABLES ASPIRANTES
ABSAUGWERKBÄNCKE
BANCOS ASPIRANTES



BSN - BSAN



BSN



I banchi aspiranti trovano vasto impiego nelle operazioni di saldatura, sbavatura e molatura. Disponibile in due configurazioni in base alla necessità: versione base (BSN), con elettroaspiratore per espulsione diretta (BSAN).



Extracting benches are generally used in the welding, chipping, and grinding operations. It is available in two versions: basic model (BSN), with fan (BSAN).



Les tables de travail aspirantes sont largement utilisées pour le soudage, l'ébavurage et le meulage. Deux modèles sont disponibles suivant l'application : version de base (BSN), avec ventilateur aspirant pour expulsion directe (BSAN).



Die Absaugbänke werden häufig für Schweißen, Entgraten und Schleifen verwendet. Fier verschiedene Beduerfnisse sind 2 Ausfuehrungen in Programm;BSN – Basisausfuehrung BSAN.



Las mesas aspirantes encuentran su empleo en los trabajos de soldadura, esmerilladura, de-sbaradura. Disponible en dos modelos según necesidad: versión base (BSN), con electroaspirador para expulsión directa (BSAN)

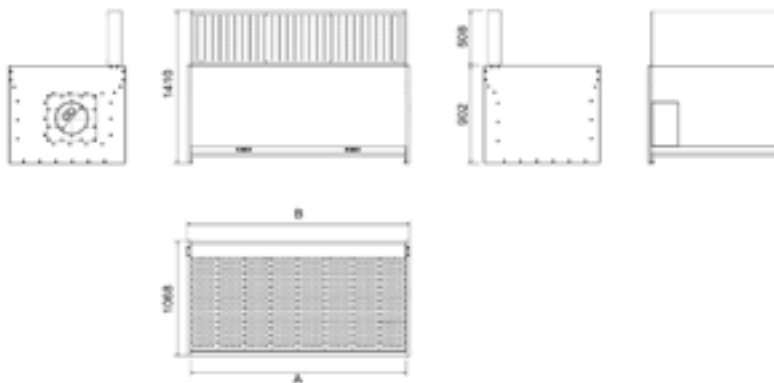
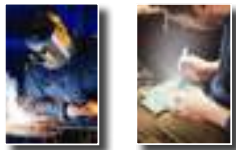

CODE	A mm	B mm	D Ø mm
BSN-1000	1000	1060	200
BSN-1500	1500	1560	250
BSN-2000	2000	2060	300
BSN-2500	2500	2560	350



OPTIONALS

	Model	m ³ /h	L mm
	BSN-1000	1850	1000
	BSN-1500	2775	1500
	BSN-2000	3700	2000
	BSN-2500	4625	2500



BSN-W-LAMP1000/1500/2000/2500

Kit luce per parete aspirante
Light kit for suction wall
Kit lumiere pour paroi aspirante
Beleuchtung für saugende Rückwand
Kit luz para pared aspirante



BSN-WALL
Pareti laterali fisse
Fixed non-suction side walls
Parois laterales fixes
Feste seitewände
Paredes laterales fijas

BSN - BSAN



STANDARD

Piano aspirante in acciaio zincato
Suction top made of galvanised sheet metal
Plan aspirant en tole galva
Saugende arbeitsfläche aus verzinktem blech
Base de aspiración en chapa galvanizada

STANDARD

Cassetto raccolta polveri
Dusts tray
Tiroir de récupération de la poussière
Straubsammelbehälter
Cajón de recolección polvo



BSAN

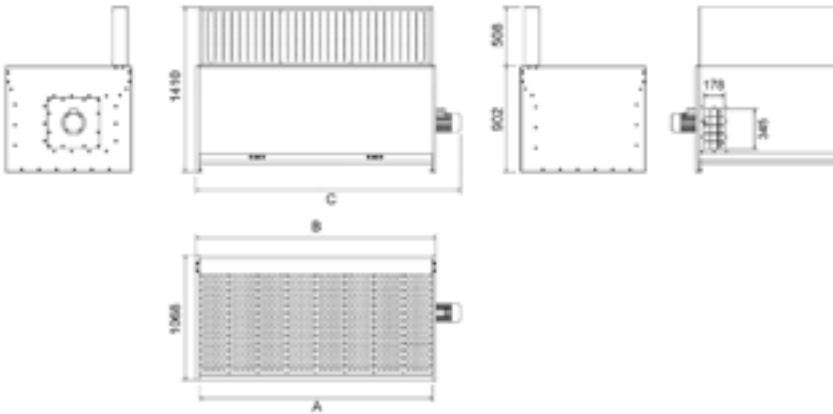

CODE	A mm	B mm	C mm
BSAN-1000	1000	1060	1268
BSAN-1500	1500	1560	1768
BSAN-2000	2000	2060	2268
BSAN-2500	2500	2560	2853

OPTIONALS



BSAN-W-LAMP1000/1500/2000/2500

Kit luce per parete aspirante
Light kit for suction wall
Kit lumière pour paroi aspirante
Beleuchtung für saugende Rückwand
Kit luz para pared aspirante



BSAN-WALL
Pareti laterali fisse
Fixed non-suction side walls
Parois laterales fixes
Feste seitewände
Paredes laterales fijas



	Model	m ³ /h	L mm	V	Hz	pahses	kW	HP	kg/m ²	dB
	BSAN-1000	1850	1000	230/400	50	3P	0,55	0,75	250	76
	BSAN-1500	2775	1500	230/400	50	3P	0,75	1	250	77
	BSAN-2000	3700	2000	230/400	50	3P	0,75	1	250	79
	BSAN-2500	4625	2500	230/400	50	3P	1,1	1	250	81



BSJET-DF BSWELD



BSJET-DF



Banchi aspiranti modello BSJET-DF è completo di aspiratore e filtri a cartuccia, con sistema di pulizia automatico (IFA-BGIA-M- PES), il modello BSWELD è completo di elettroaspiratore e filtri a cartuccia (M-CELL 7033).



Benches BSJET-DF aspiring model comes with a vacuum cleaner and cartridge filters with automatic cleaning system (IFA-BGIA-M- PES), the BSWELD model is complete with steam and cartridge filters (M-CELL 7033).



Bancs BSJET-DF modèle aspirant est livré avec un aspirateur et des filtres à cartouche avec système de nettoyage automatique (IFA-BGIA-M- PSE), le modèle de BSWELD est complète avec filtres à vapeur et de la cartouche (M-CELL 7033).



Bänke BSJET-DF aufstrebende Modell kommt mit einem Staubsauger und Patronenfilter mit automatischem Reinigungssystem (IFA-BGIA-M- SPE), die BSWELD Modell ist komplett mit Dampf und Patronenfilter (M-CELL 7033).



Bancos BSJET-DF aspirante a modelo viene con una aspiradora y filtros de cartucho con sistema de limpieza automática (IFA-BGIA-M- PES), el modelo BSWELD se completa con filtros de vapor y el cartucho (M-CELL 7033).

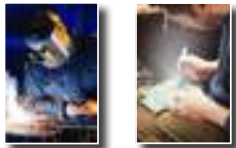

OPTIONALS

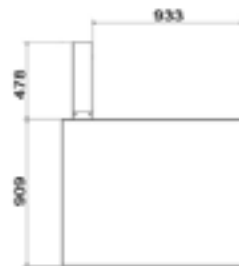

BSJET-DF-W-LAMP1000/1500/2000/2500

Kit luce per parete aspirante
Light kit for suction wall
Kit lumière pour paroi aspirante
Beleuchtung für saugende Rückwand
Kit luz para pared aspirante



BSJET-DF-WALL

Pareti laterali fisse
Fixed non-suction side walls
Parois laterales fixes
Feste seitewände
Paredes laterales fijas

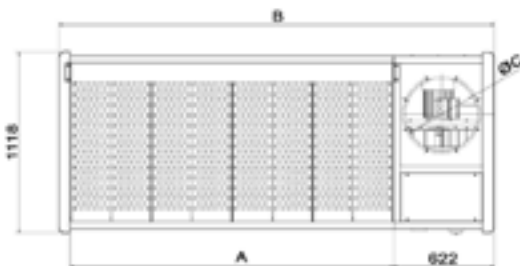

CODE	A mm	B mm	C Ø mm
BSJET-DF-1500	1500	2195	420
BSJET-DF-2000	2000	2695	450
BSJET-DF-2500	2500	3195	450



BSJET-DF-DIF-1500/2000/2500

Diffusore
Air diffuser
Diffuseur
Luftverteiler
Difusor de aire

BSJET-DF-SA-1500/2000/2500

Afon
Silencer
Silencieux
Schalldämpfer
Silenciador

	Model	m ³ /h	L mm	V	Hz	phases	kW	HP	kg/m ²	IFA/BGIA
	BSJET-DF-1500	4000	1500	230/400	50	3P	2,2	3	250	M-PES-TF Ø 325 H 660 mm
	BSJET-DF-2000	5000	2000	230/400	50	3P	3	4	250	M-PES-TF Ø 325 H 660 mm
	BSJET-DF-2500	6860	2500	230/400	3 50	3P	4	5,5	250	M-PES-TF Ø 325 H 660 mm

BSJET-DF BSWELD



STANDARD

Piano aspirante in acciaio zincato
Suction top made of galvanised sheet metal
Plan aspirant en tole galva
Saugende arbeitsfläche aus verzinktem blech
Base de aspiración en chapa galvanizada

STANDARD

Cassetto raccolta polveri
Dusts tray
Tiroir de récupération de la poussière
Straubsammelbehälter
Cajón de recolección polvo

BSWELD

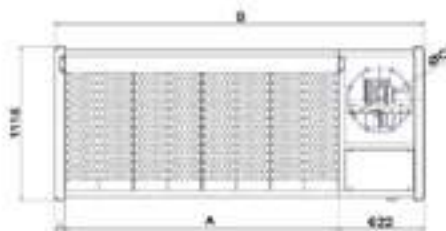

CODE	A mm	B mm	C Ø mm
BSWELD-1500	1500	2195	420
BSWELD-2000	2000	2695	450
BSWELD-2500	2500	3195	450



OPTIONALS



BSWELD-W-LAMP1000/1500/2000/2500

Kit luce per parete aspirante
Light kit for suction wall
Kit lumière pour paroi aspirante
Beleuchtung für saugende Rückwand
Kit luz para pared aspirante



BSWELD-WALL

Pareti laterali fisse
Fixed non-suction side walls
Parois laterales fixes
Feste seitewände
Paredes laterales fijas



BSWELD-DIF-1500/2000/2500

Diffusore
Air diffuser
Diffuseur
Luftverteiler
Difusor de aire

BSWELD-SA-1500/2000/2500

Afon
Silencer
Silencieux
Schalldämpfer
Silenciador

	Model	m ³ /h	L mm	V	Hz	phases	kW	HP	IFA/BGIA
	BSWELD-1500	4100	1500	230/400	50	3P	2,2	3	M-cel 7033 Ø 325 H 660 mm
	BSWELD-2000	5100	2000	230/400	50	3P	3	4	M-cel 7033 Ø 325 H 660 mm
	BSWELD-2500	6960	2500	230/400	50	3P	4	5,5	M-cel 7033 Ø 325 H 660 mm



www.filcar.eu

CANALINE IN ALLUMINIO

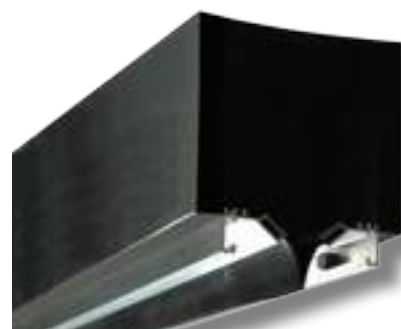
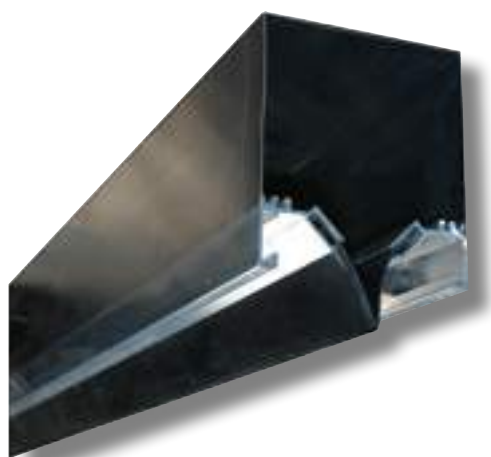

ALUMINIUM TRACKS
RAILS EN ALUMINIUM
ALU-SAUGSCHLITZKANÄLE
CARRILES DE ALUMINIO

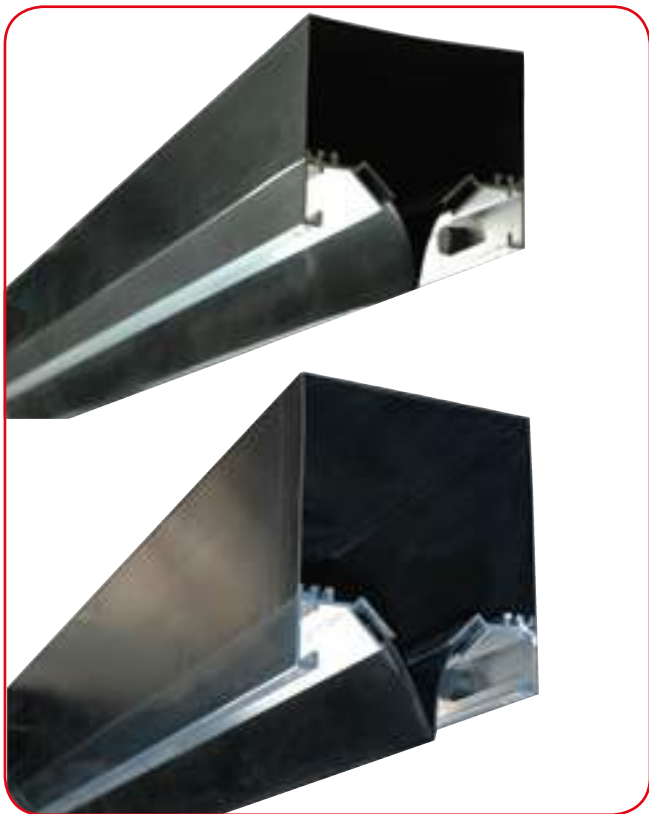

Canalina modulare in alluminio per aspirazione di gas e fumi inquinanti tramite elementi scorrevoli porta-tubo o porta-braccio articolato. Caratterizzata da estrema flessibilità di utilizzo, leggerezza e ampia gamma disponibile, la serie CZ è disponibile in varie dimensioni per sopporre a diversi volumi di aspirazione richiesti.



Modular aluminium track for extracting pollutant gases and fumes via sliding hose support elements or articulated arm supports. The CZ series is extremely flexible, lightweight and available in a wide range of models and sizes so that it is suitable for various extraction volume requirements.



Rail modulaire en aluminium pour aspiration de gaz et fumées polluantes par l'intermédiaire d'éléments coulissants porte-tuyau ou porte-bras articulé. Caractérisé par une extrême souplesse d'utilisation, sa légèreté et sa gamme très large, la série CZ existe en plusieurs dimensions pour satisfaire les différents volumes d'aspiration nécessaires.



Modularer Saugschlitzkanal aus Aluminium für die Abgas- und Rauchabsaugung über mit Laufwagen montierte Schläuche und Gelenkarme. Die Serie CZ zeichnet sich durch außergewöhnliche Flexibilität, Leichtigkeit und ein umfassendes Angebot aus. Sie ist in diversen Abmessungen erhältlich, um den verschiedenen Anforderungen in Hinblick auf das Absaugvolumen nachzukommen.



Carril modular de aluminio para aspirar gases y humos contaminantes mediante elementos deslizantes porta-tubo o porta-brazo articulado. Caracterizada por la gran flexibilidad de uso, el poco peso y la amplia gama disponible, la serie CZ propone varias dimensiones para dar respuesta a los distintos volúmenes de aspiración requeridos.

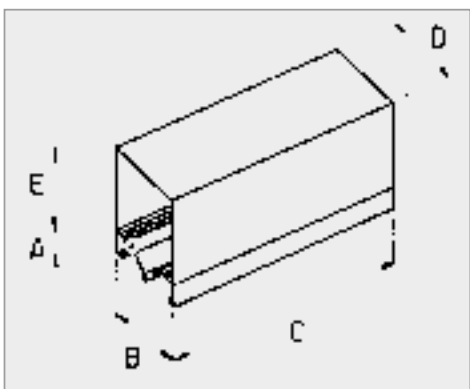
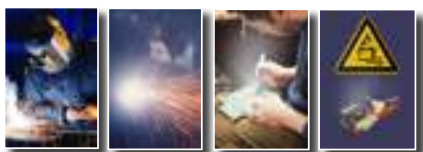



Dettagli tecnici - Technical details - Données techniques - Technische Daten - Datos Técnicos

Model	A (mm)	B (mm)	C (mm)	D (mm)	E (mm)	Ø eq (mm)	m³/h MAX	c.f.m. MAX	Kg	Lbs
CZ-3000	53	220	3000	220	135	195	2.350	1382	26,5	58,4
CZ-6000	53	220	6000	220	135	195	2.350	1382	53	116,8
CZ1-2000	53	220	2000	220	200	248	3800	2234	19	41,9
CZ1-6000	53	220	6000	220	200	248	3800	2234	54	119

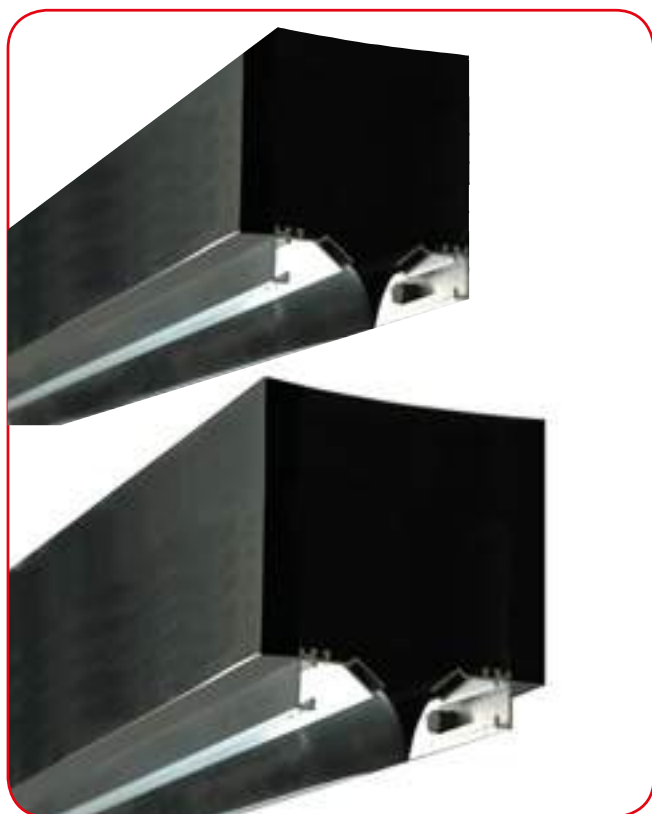
CZ2 - CZ3



 Canalina modulare in alluminio per aspirazione di gas e fumi inquinanti tramite elementi scorrevoli porta-tubo o porta-braccio articolato. Caratterizzata da estrema flessibilità di utilizzo, leggerezza e ampia gamma disponibile, la serie CZ è disponibile in varie dimensioni per sopperire a diversi volumi di aspirazione richiesti.

 Modular aluminium track for extracting pollutant gases and fumes via sliding hose support elements or articulated arm supports. The CZ series is extremely flexible, lightweight and available in a wide range of models and sizes so that it is suitable for various extraction volume requirements.

 Rail modulaire en aluminium pour aspiration de gaz et fumées polluantes par l'intermédiaire d'éléments coulissants porte-tuyau ou porte-bras articulé. Caractérisé par une extrême souplesse d'utilisation, sa légèreté et sa gamme très large, la série CZ existe en plusieurs dimensions pour satisfaire les différents volumes d'aspiration nécessaires.

 Modularer Saugschlitzkanal aus Aluminium für die Abgas- und Rauchabsaugung über mit Laufwagen montierte Schläuche und Gelenkarme. Die Serie CZ zeichnet sich durch außergewöhnliche Flexibilität, Leichtigkeit und ein umfassendes Angebot aus. Sie ist in diversen Abmessungen erhältlich, um den verschiedenen Anforderungen in Hinblick auf das Absaugvolumen nachzukommen.

 Carril modular de aluminio para aspirar gases y humos contaminantes mediante elementos deslizantes porta-tubo o porta-brazo articulado. Caracterizada por la gran flexibilidad de uso, el poco peso y la amplia gama disponible, la serie CZ propone varias dimensiones para dar respuesta a los distintos volúmenes de aspiración requeridos.

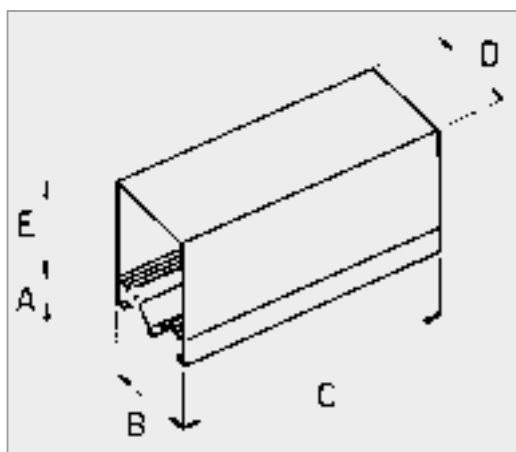
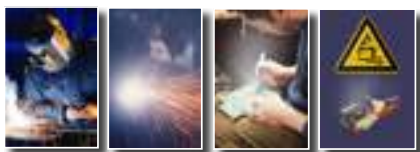

Dettagli tecnici - Technical details - Données techniques - Technische Daten - Datos Técnicos

Model	A (mm)	B (mm)	C (mm)	D (mm)	E (mm)	Ø eq (mm)	m³/h MAX	c.f.m. MAX	Kg	Lbs
CZ2-2000	53	220	2000	220	400	334	6.900	4057	20	44
CZ2-6000	53	220	6000	220	400	334	6.900	4057	58	128
CZ3-2000	53	220	2000	350	500	472	13.850	8144	24	53
CZ3-6000	53	220	6000	350	500	472	13.850	8144	84	185





XTK1 - XTK2



 Canalina modulare in estruso di alluminio per aspirazione di gas e fumi inquinanti tramite elementi scorrevoli porta-tubo o porta-braccio articolato. La rigidità strutturale, gli elementi scorrevoli di fissaggio e la pulizia estetica fanno della serie XTK un prodotto altamente tecnico e performante nell'ambito di impianti scorrevoli di aspirazione.

 Modular conduit in extruded aluminium for extracting pollutant gases and fumes via sliding hose support elements or articulated arm supports. Thanks to its rigid structure, sliding mounting elements and simple design, the XTK series represents a high technology, high performance product in the sliding extraction systems sector.

 Rail modulaire en aluminium extrudé pour aspiration de gaz et fumées polluants par l'intermédiaire d'éléments coulissants porte-tuyau ou porte-bras articulé. La rigidité de la structure, les éléments coulissants de fixation et la pureté esthétique font de la série XTK un produit hautement technique et performant dans le cadre d'installations coulissantes d'aspiration.

 Modularer Saugschlitzkanal aus stranggepresstem Aluminium für die Abgas- und Rauchabsaugung über mit Laufwagen montierte Schläuche und Gelenkarme. Dank der steifen Konstruktion, der beweglichen Befestigungselemente und des sauberen Designs präsentiert sich die Serie XTK als ein hochtechnisches und leistungsstarkes Produkt im Bereich der mobilen Absauganlagen.

 Carril modular de aluminio extrusado para aspirar gases y humos contaminantes mediante elementos deslizantes porta-tubo o porta-brazo articulado. Rigidez estructural, elementos deslizantes de fijación y sencillez estética convierten la serie XTK en un sistema deslizando de aspiración tecnológicamente avanzado y funcional.

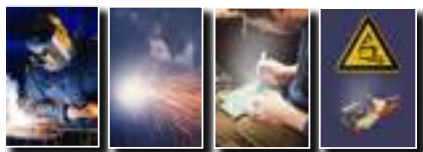

XTK1 - XTK2

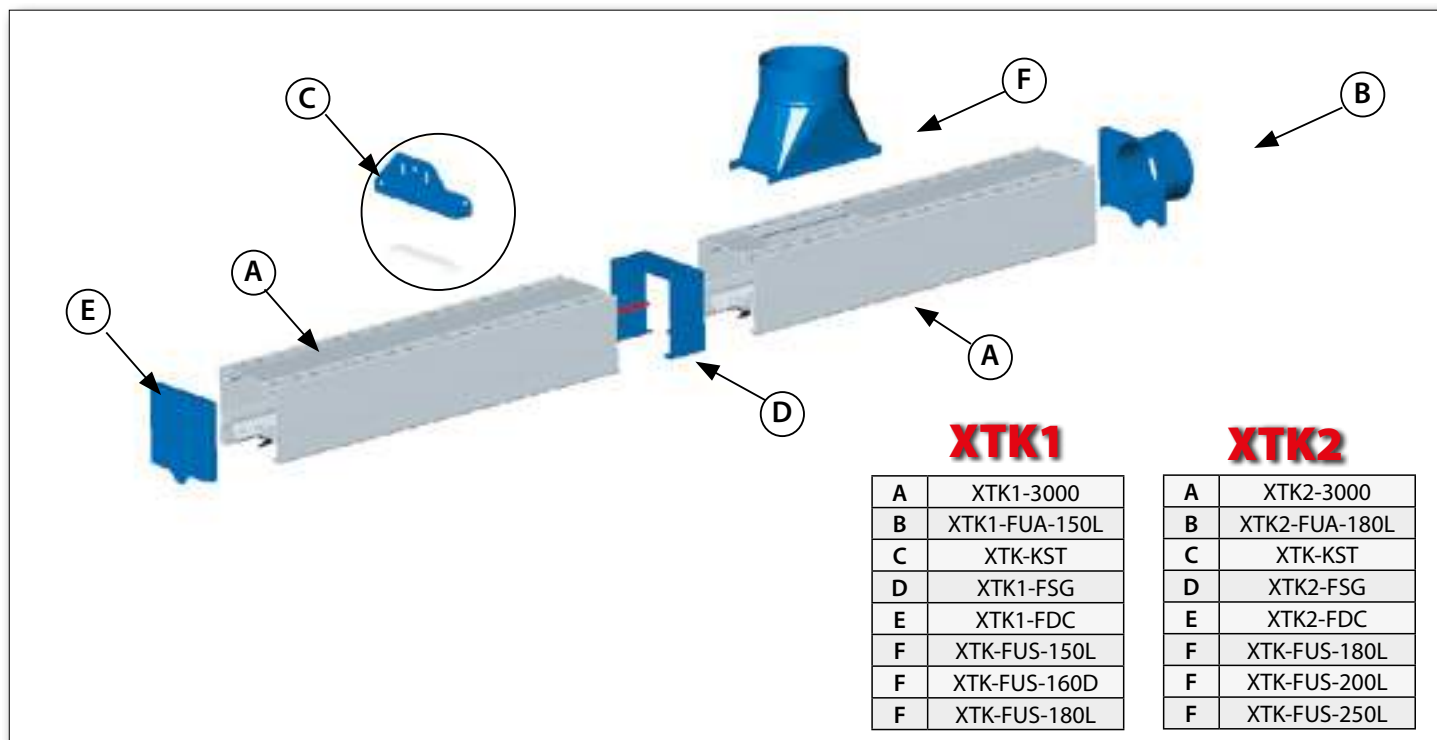

XTK1

A	XTK1-3000
B	XTK1-FUA-150L
C	XTK-KST
D	XTK1-FSG
E	XTK1-FDC
F	XTK-FUS-150L
F	XTK-FUS-160D
F	XTK-FUS-180L

XTK2

A	XTK2-3000
B	XTK2-FUA-180L
C	XTK-KST
D	XTK2-FSG
E	XTK2-FDC
F	XTK-FUS-180L
F	XTK-FUS-200L
F	XTK-FUS-250L

Dettagli tecnici - Technical details - Données techniques - Technische Daten - Datos Técnicos

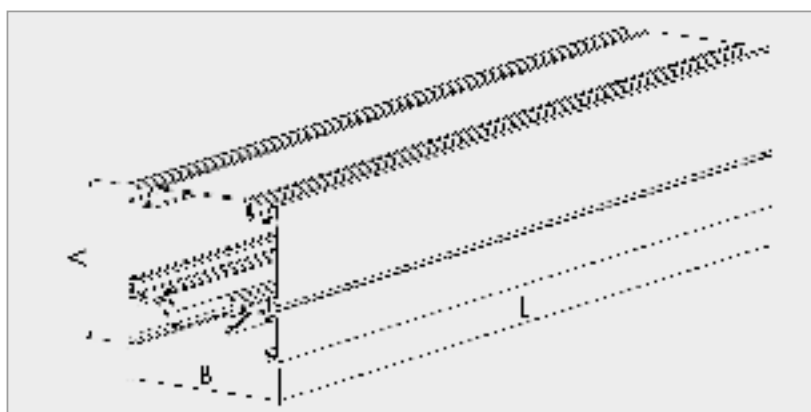

Model	A (mm)	B (mm)	L (mm)	Øeq (mm)	m³/h MAX	c.f.m. MAX	Kg	Lbs
XTK1-2000	180	200	2000	170	1.800	1058	18,6	41
XTK1-3000	180	200	3000	170	1.800	1058	27,9	61,5
XTK1-4000	180	200	4000	170	1.800	1058	37,2	82
XTK1-6000	180	200	6000	170	1.800	1058	55,8	123
XTK2-2000	240	200	2000	210	2.750	1617	20,4	45
XTK2-3000	240	200	3000	210	2.750	1617	30,6	67,5
XTK2-4000	240	200	4000	210	2.750	1617	40,8	89
XTK2-6000	240	200	6000	210	2.750	1617	61,2	135



www.filcar.eu

ASPIRATORI



FANS

VENTILATEURS

VENTILATOREN

ASPIRADORES

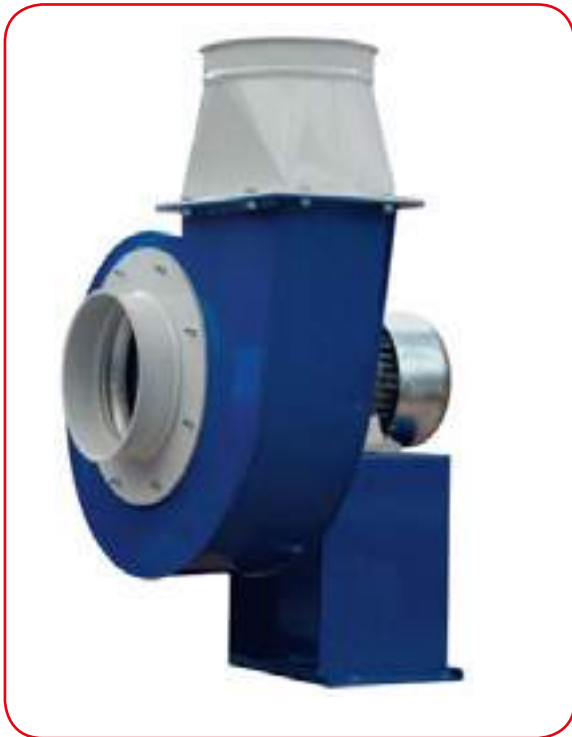

Elettroaspiratore in lamiera d'acciaio completo di flange di entrata e uscita. Ventilatore orientabile adatto per portate medio alte, pressioni medie.



Metal sheet steel fan complete with inlet and outlet flanges. Fan adjustable suitable for medium high, medium pressure.



Electro-aspirateur en tôle d'acier avec brides d'entré et de sortie. Fan réglable adapté à haute, moyenne pression moyenne.



Ventilator aus Stahlblech mit Druck und Sauganschlüssen. Fan verstellbar passend für mittel hoher, mittlerer Druck.



Aspirador de acero con bocas de entrada y salida. Ventilador ajustable adecuado para medio-alto, de media presión.

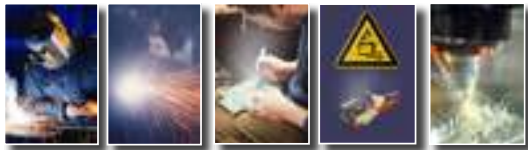

230V-400V / 3phase / 50Hz

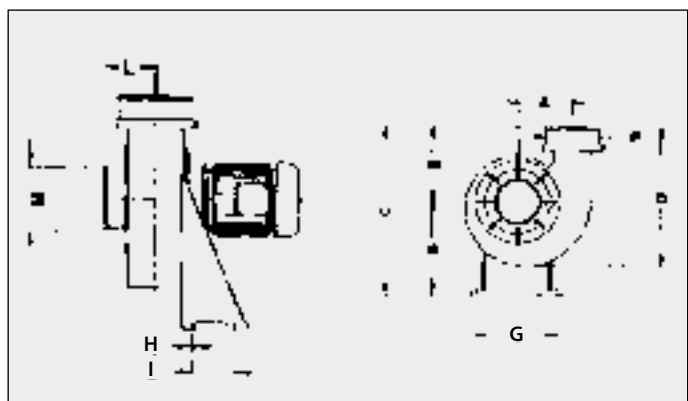
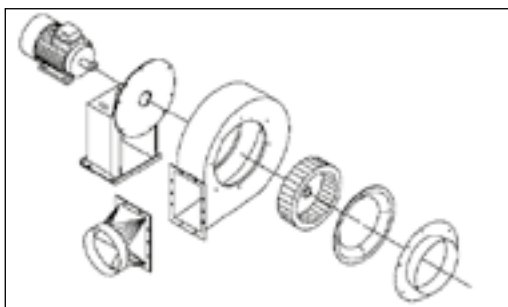
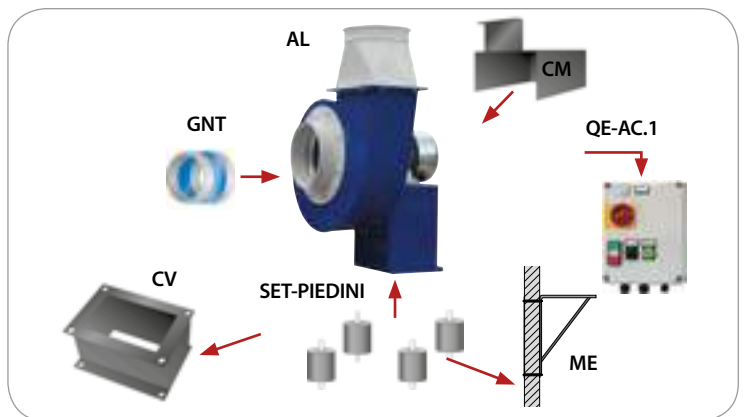



	AL 50	AL 100	AL 150	AL 200	AL 300	AL 400	AL 550	AL 750	AL 1000	AL 1500	AL 2000
Q [m ³ /h]	P _i [mmH ₂ O]										
100		85	120								
200		87	123		140						
300		88	124	124	140						
350	56	89	126	125	140						
400	58.5	90	128	126	140						
500	61	92	132	127	140						
600	67.5	93	137	128	140						
700	67.5	98	142	135	141						
800	63	102	148	136	142						
880	60	105	147	137	142						
900		107	150	137	142						
1000		110	153	138	144						
1100		112	157	140	147						
1200		113	162	143	150						
1300		113	167	147	152						
1500		112	172	158	162	270					
1700		107	172	167	170	275	275				
1800		106	170	173	177	287	272				
1900		105	167	178	182	286	270				
2100		100		188	190	285	268				
2160				187	193	284	264				
2400					194	281	260				
2520					188	279	259				
2700					185	275	258				
2800					184	271	257				
2990					183	267	256				
3000						264	255	325	340		
3240						260	252	322	338		
3400						254	250	320	336		
3600						247	245	317	334	360	
3800						238	240	315	332	370	
4000						232	230	310	330	387	
4100						220	220	305	327	381	385
4320						214	205	295	324	377	387
4680						195	195	285	322	374	388
4750						180	180	280	318	369	390
5000						170	168	275	312	361	393
5400						153	155	270	295	350	388
6000						81	145	250	275	346	382
6150							110	240	268	340	378
6500							90	225	255	333	368
6850								215	240	325	360
7000								200	230	320	355
7650								160	195	305	350
8000								132	175	285	341
8500								105	150	260	305
9000									118	240	300
9100									108	230	292
9500										210	285
10000										200	275
10800										160	220
11000										150	225
11500										118	200
12000											180
13000											125

Model	A	B	C	D	E	F,M (.../C)	F,M (.../D)	G	H	I	L	Kg	HP	kW	R.P.M	dB
AL-50	92	190	468	492	278	150 R*	160 L*	195	8,5	65	120	12	0,5	0,37	2800	66
AL-100	151	283	601	486	318	180 R*	160 L*	265	8,5	95	125	20	1	0,75	2800	68
AL-150	151	283	601	486	318	180 R*	160 L*	265	8,5	95	125	22	1,5	1,1	2800	72
AL-200	196	374	756	624	382	200 R*	200 L*	250	8,5	130	135	32	2	1,5	2800	75
AL-300	196	374	756	624	382	200 R*	200 L*	250	8,5	130	135	35	3	2,2	2800	78
AL-400	286	500	965	835	465	250 R*	250 L*	289	12	197	187	77	4	3	2800	80
AL-550	286	500	965	835	465	250 R*	250 L*	289	12	197	187	82	5,5	4	2800	81
AL-750	321	560	1080	935	520	300 R*	315 L*	337	12	237	201	118	7,5	5,5	2800	84
AL-1000	321	560	1080	935	520	350 R*	355 L*	337	12	237	201	128	10	7,5	2800	85
AL-1500	355	600	1180	1052	580	380 R*	400 L*	395	14	337	217	203	15	11	2800	89
AL-2000	355	600	1180	1052	580	400 R*	400 L*	395	14	337	217	215	20	15	2800	89

* L= liscio/smooth/ lisse / glatt / liso
 *R= risvoltato/folded/plié/gefaltet/plegada



 Elettroaspiratore in fusione di alluminio completo di flange di entrata e uscita. Ventilatore orientabile, adatto per portate basse e pressioni medio/alte.

 Cast aluminum fan with inlet and outlet flanges. Fan adjustable, suitable for low flow rates and pressures medium / high.

 Electro-aspirateur en fusion d'aluminium avec brides à entrée et de sortie. Fan réglable, adapté aux débits et pressions moyennes / haute faible débit.

 Ventilator aus Aluminium einschl. Saug- und Druckstutzen. Fan einstellbar, geeignet für niedrige Durchflussraten und Drücke mittel / hoch.

 Aspirador en fundición de aluminio con bocas de entrada y salida. Ventilador ajustable, apto para caudales bajos y presiones medias / altas.

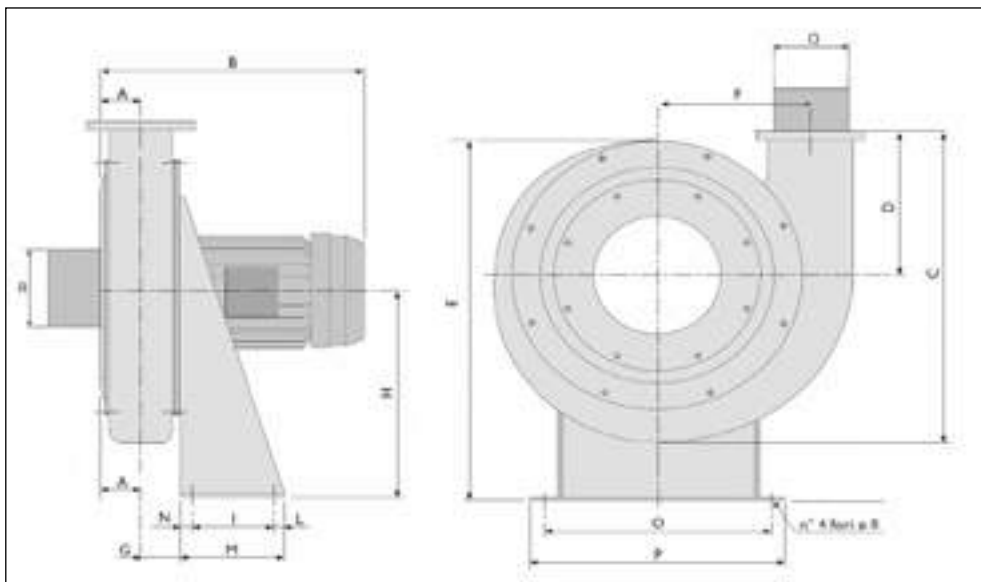

Model	A (mm)	B (mm)	C (mm)	D (mm)	E (mm)	F (mm)	G (mm)	H (mm)	I (mm)	L (mm)	M (mm)	N (mm)	O (mm)	P (mm)	Q (mm) outlet	R (mm) inlet	Kg	HP	kW	R.P.M
AS-25/D	50	286	346	154	404	164	48	233	95	12,5	120	12,5	265	295	75 L*	120 L*	12,3	0,25	0,18	2800
AS-50/C	50	288	385	176	441	180	46	253	95	12,5	120	12,5	265	295	120 L*	150 R*	17,0	0,50	0,37	2800
AS-50/D	50	288	385	176	441	180	46	253	95	12,5	120	12,5	265	295	120 L*	160 L*	17,0	0,50	0,37	2800
AS-75/C	50	314	385	176	441	180	46	253	95	12,5	120	12,5	265	295	120 L*	150 R*	18,0	0,75	0,55	2800
AS-75/D	50	314	385	176	441	180	46	253	95	12,5	120	12,5	265	295	120 L*	160 L*	18,0	0,75	0,55	2800
AS-100/C	63	348	431	197	494	201	54	283	95	12,5	120	12,5	265	295	120 L*	200 R*	21,0	1	0,75	2800
AS-100/D	63	348	431	197	494	201	54	283	95	12,5	120	12,5	265	295	120 L*	200 L*	21,0	1	0,75	2800
AS-150/C	58	339	521	250	577	231	49	321	140	30	200	30	310	340	120 L*	200 R*	26,9	1,5	1,1	2800
AS-150/D	58	339	521	250	577	231	49	321	140	30	200	30	310	340	120 L*	200 L*	26,9	1,5	1,1	2800
AS-200/C	58	377	521	250	577	231	49	321	140	30	200	30	310	340	120 L*	200 R*	34,4	2	1,5	2800
AS-200/D	58	377	521	250	577	231	49	321	140	30	200	30	310	340	120 L*	200 L*	34,4	2	1,5	2800

* L= liscio/smooth/ lisse / glatt / liso

*R= risvoltato/folded/plié/gefaltet/plegada

	AS25	AS50	AS75	AS100	AS150	AS200
Q [m³/h]	P _T [mm H ₂ O]					
100						
150	115					
200	114					
250	113	150				
300	110	146				
350	109	145	170			
400	108	142	164			
450	99	139	162	194		
500	94	137	160	194	242	
600	83	136	152	193	239	305
700	58	112	142	186	229	302
800		90	130	180	224	295
900			112	174	220	288
1000				165	210	280
1100				155	203	275
1200					192	270
1300						260
1400						254
1600						230



AL



100/1300 Q[m³/h]
56-393 Pt[mmH₂O]
MED PRESS



AS



150/1600 Q[m³/h]
58/305 Pt[mmH²O]
HIGH PRESS

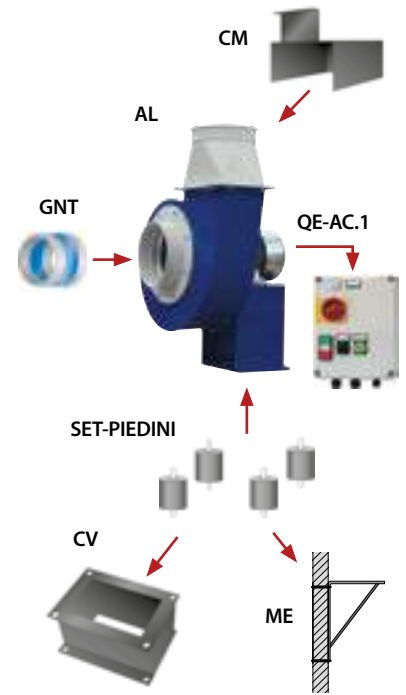

AL-100/C

AL-100/D

ITALIAN STANDARD



EUROPEAN STANDARD



BOX INSONORIZZANTE - SOUNDPROOF BOX - BOÎTE POUR LA RÉDUCTION - SCHAHLDÄMMBOX FÜR VENTILATOR - BOX INSONORIZANTE







STANDARD ITALIANO

BOX-INS-AL100/150
BOX-INS-AL200/300BOX-
INS-AL400
BOX-INS-AL550
BOX-INS-AL750
BOX-INS-AL1000

EUROPEAN STANDARD





BOX-INS-AL100/150-D
BOX-INS-AL200/300-D
BOX-INS-AL400-D
BOX-INS-AL550-D
BOX-INS-AL750-D
BOX-INS-AL1000-D

-  Box insonorizzante per attento rumorosità degli aspiratori.
-  Soundproof box to reduce the fans noise.
-  Boîte pour la réduction du bruit acoustique des.
-  Schahldämmbox für Ventilator. Komplett mit Ansaug- und Ausblasöffnung für Innenund Aussenpositionierung.
-  Box insonorizante para la reducción del ruido del electroaspirador.

MENSOLA A PARETE - WALL BRACKET - SUPPORT MURALE - WANDHALTERUNG FÜR VENTILATOR - ENCIMERA A PARED







ME-50-300/P
ME-400-500
ME-750-1000

-  Mensola a parete per sostegno aspiratore. ME-50-300/P è compreso di piedini.
-  Wall bracket to stand the fan. ME-50-300 / P is comprised of pins.
-  Support mural pour soutenir l'aspirateur. ME-50-300 / P est constitué de broches.
-  Wandhalterung für Ventilator. ME-50-300 / P wird von Stiften besteht.
-  Encimera a pared para el montaje de los aspiradores. ME-50-300 / P se compone de pasadores.

COPRI MOTORE- COVER FOR ELECTRIC MOTOR - COUVERCLE POUR MOTEUR - MOTORDECKEL - CUBREMOTOR







CM-0.5-0.75
CM-1-1.5
CM-2-3
CM-4-5.5
CM-7.5-10
CM-15-20

-  Copertura per motore elettrico degli aspiratore.
-  Cover for electric motor of the fan.
-  Couvercle pour moteur électrique de l'aspirateur.
-  Motordeckel.
-  Cubremotor para aspiradores.

PIEDINI ANTI VIBRANTI- ANTI-VIBRATION FEET - PIEDS ANTI-VIBRATION - SCHWINGUNGSDÄMPFER - GOMAS ANTIVIBRACIONES







SET-PIEDINI/P
SET-PIEDINI/M
SET-PIEDINI/G

-  Piedini antivibranti per collegamento aspiratore con relativo supporto.
-  Anti-vibration feet for connection with suction stand.
-  Pieds anti-vibration pour la connexion avec le support d'aspiration.
-  Schwingungsdämpfer.
-  Gomas antivibraciones para enlace del aspirador con el relativo soporte.

GIUNTO ANTI VIBRANTI- VIBRATION-PROOF - JOINT ANTI-VIBRATIONS - FLEXIBLE VERBINDUNG - JUNTA ANTIVIBRACIONES





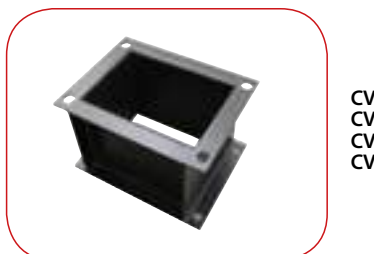

GNT-100
GNT-120
GNT-150
GNT-180
GNT-200
GNT-220
GNT-250
GNT-280
GNT-670
GNT-320
GNT-350
GNT-380
GNT-400

-  Giunto antibrante con risvolti per collari.
-  Vibration-proof coupling with lip for collars.
-  Joint anti-vibrations pour collier.
-  Flexible Verbindung mit Rand.
-  Junta antivibraciones con solapa para collares.

CAVALLETTO A PAVIMENTO - STAND FOR EXHAUSTER - SUPPORT POUR SOUTENIR - VENTILATORGESTELL - CABALLETE PARA SOPORTE



CV-50-300
CV-400-550
CV-750-1000
CV-1500-2000

-  Cavalletto per supporto aspiratore.
-  Stand for exhauster fan.
-  Support pour soutenir l'aspirateur.
-  Ventilatorgestell.
-  Caballete para soporte del aspirador.



ALLUFLEX







ASPIRFLEX



INTERRUPTORE TERMICO- SIMPLE SWITCH- INTERRUPTEUR SIMPLE - SCHALTER FÜR VENTILATOR - INTERRUPTOR SENCILLO



INT-0,6-1,0 A/CC
INT-1,0-1,6 A/CC
INT-1,6-2,5 A/CC
INT-2,5-4,0 A/CC
INT-4,0-6,3 A/CC
INT-6,3-10,0 A/CC
INT-9,0-14,0 A/CC





-  Interruttore semplice per start e stop aspiratore comprensivo di protezione termica (non comprende la bobina di sgancio).
-  Simple switch to start and stop the fan, including thermal protection (does not include the release coil).
-  Un interrupteur simple pour démarrer et arrêter l'aspirateur y compris la protection thermique (n'inclut pas la bobine de déclenchement).
-  EIN/AUS Schalter für Ventilator mit Motorschutz.
-  Interruptor sencillo con protección térmica completo.

QUADRO ELETTRICO - ELECTRICAL PANEL - TABLEAU ÉLECTRIQUE - CE-KONFORM SCHALTTAFEL - CUADRO ELÉCTRICO



QE-AC1/1.0
QE-AC1/1.5
QE-AC1/2.0
QE-AC1/3.0
QE-AC1/4.0
QE-AC1/5.5





QE-AC2/5.5
QE-AC2/7.5
QE-AC2/10
QE-AC2/15
QE-AC2/20

-  Quadro elettrico conforme alla normativa CE. Comprensivo di sezionatore e predisposto per un contatto esterno (es. utilizzabile per ON/OFF automatico dell'aspiratore. Quadri QE-AC2 avviamento stella triangolo per limitare i consumi in fase di spunto).
-  Electrical panel CE compliant, which includes disconnecter and prepared for an external contact (ex. It can be used for the automatic ON / OFF start of the fan). QE-AC2 panels has star delta start in order to limit energy consumption during take-off.
-  Tableau électrique conforme à règlements CEE. Inclusive d'un interrupteur et prédisposé pour un contact externe (ex. utilisable pour un system ON/OFF automatiquement par l'aspirateur. Tableau QE-AC2 démarrage étoile-triangle pour réduire la consommation pendant la phase de allumage).
-  CE-konform Schalttafel mit Schalter und bereit für externe Signalen (z.B. für automatische EIN/AUS des Ventilators. QE-AC2 Schalttafel Stern-Dreieck-Betrieb).
-  Cuadro eléctrico a norma CE para aspirador centralizado con predisposición para comando manual y automático del señal remoto (ejemplo puede ser utilizado como ON/OFF del aspirador. Cuadros QEAC2 con arranque estrella /triangulo para bajar el consumo en fase de arranque).

QUADRO ELETTRICO INVERTER - ELECTRICAL PANEL INVERTER - TABLEAU ÉLECTRIQUE INVERTER - STEUERUNG INVERTER - CUADRO ELÉCTRICO INVERTER



QE-AC1/4.0-INV
QE-AC1/5.5-INV
QE-AC1/7.5-INV
QE-AC1/10-INV
QE-AC1/15-INV
QE-AC1/20-INV

-  Quadro elettrico con Inverter. Permette la regolazione automatica dell'aspiratore in funzione della richiesta. Riduce drasticamente i consumi elettrici.
-  Electrical panel with Inverter. It allows the fan automatic adjustment according to demand. It drastically reduces electrical costs.
-  Tableau électrique avec Inverter. Permet la régularisation automatique de l'aspirateur par fonction de le demande. Il réduit considérablement la consommation d'énergie.
-  Steuerung mit Inverter. Durch die automatische Unterdruckbemessung wird der Ventilatorleistung angepasst. Stromverbrauch wird entsprechend sinken.
-  Cuadro eléctrico para aspirador centralizado con inverter y sensor diferencial para regular la potencia del motor en relacion a la demanda. Reduce en manera importante los consumos electricos.



QE-AC1T/1HP
QE-AC1T/1,5HP
QE-AC1T/2HP
QE-AC1T/3HP
QE-AC1T/4HP
QE-AC1T/5,5HP



Quadro elettrico con ricevitore compreso di telecomando a radiofrequenza per accendere e spegnere l'aspiratore dalla zona di lavoro.



Electrical panel with receiver including remote control radio frequency to turn on and turn off the vacuum cleaner from the working area.



Tableau électrique avec récepteur comprenant distance fréquence radio de contrôle pour allumer et éteindre l'aspirateur de la zone de travail.



Elektrische Schalttafel mit Empfänger mit Fernbedienung Radiofrequenz zum Ein- und Ausschalten des Staubsaugers aus dem Arbeitsbereich.



Quadro eléctrico con receptor incluyendo a distancia por radiofrecuencia de control para encender y apagar la aspiradora de la zona de trabajo.

*S38-TRQ038200-KIT - Telecomando a 2 tasti - 2-button remote control - 2-bouton de la télécommande - 2-Tasten-Fernbedienung - 2 botones de control remoto.

QUADRI - ASPIRATORI

ASPIRATORI-FANS-VENTILATEURS-VENTILATOREN-ELECTROASPIRADORES

QUADRI ELETTRICI-TABLEAU ÉLECTRIQUE- PANELS-ZENTRALSTEUERUNGEN-CUADRO ELÉCTRICO

	CODE	AL (TRIFASE 400 V)*										AS (TRIFASE 400 V)*							
		50	100	150	200	300	400	550	750	1000	1500	2000	25	50	75	100	150	200	
INT	INT.0,6-1,0A/CC																		
	INT.1,0-1,6A/CC	.																	
	INT.1,6-2,5A/CC		.																
	INT.2,5-4,0A/CC			.	.														
	INT.4,0-6,3A/CC					.												.	.
	INT.6,3-10A/CC						.												
	INT.9,0-14A/CC							.	.	.									
QE-AC	QE-AC1/0.75																.		
	QE-AC1/1.0		.														.		
	QE-AC1/1.5			.													.		
	QE-AC1/2.0				.													.	
	QE-AC1/3.0					.													.
	QE-AC1/4.0						.												
	QE-AC1/5.5							.											
	QE-AC2/5.5								.										
	QE-AC2/7.5									.									
	QE-AC2/10										.								
QE-AC2/15											.								
QE-AC2/20												.							
QE-AC1-INV	QE-AC1/4.0.INV						.												
	QE-AC1/5.5.INV							.											
	QE-AC1/7.5.INV								.										
	QE-AC1/10.INV									.									
	QE-AC1/15.INV										.								
	QE-AC1/20.INV											.							
QE-AC1T	QE-AC1T/1HP		.														.		
	QE-AC1T/1,5HP			.													.		
	QE-AC1T/2HP				.													.	
	QE-AC1T/3HP					.													
	QE-AC1T/4HP						.												
	QE-AC1T/5,5HP							.											

* Disponibile versione monofase degli aspiratori - There are also mono-phase variants of the fans - Il existe également des variantes des aspirateurs monophasés - Ventilatoren mit Monophasen Motoren sind auf Anfrage Verfügbar - Hay a demanda con alimentación monofasica

KIT COMPLETI



**COMPLETE KITS
COMPLETS KITS
KOMPLETT KIT
KIT COMPLETOS**



Braccio articolato auto-portante con tubi rigidi in alluminio Ø150 mm per aspirazione fumi di saldatura. Dotato di staffa di fissaggio a parete e elettroaspiratore.



Articulated flexible arm Ø 150 mm for welding fume extraction. Equipped with wall bracket and fan.



Bras articulé auto-portant pour l'aspiration des fumées de soudure Ø 150 mm. Prémuni d'une console murale, il est fourni avec hotte à poignée de positionnement et clapet de régulation et aspirateur.



Selbsttragender Gelenkarm mit Rohren aus Aluminium Ø 150 zur Absaugung von Schweißrauch. Ausgestattet mit Wandbefestigungsbügel und ventilator.



Brazo articulado autoportante para aspirar humos de soldadura con tubos rígidos de aluminio Ø 150 mm. Incluye soporte a pared y Aspirador.

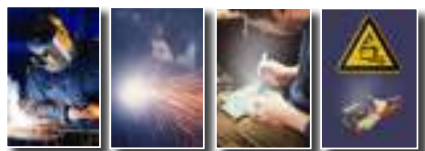



Dettagli tecnici - Technical details - Données techniques - Technische Daten - Datos Técnicos

Model					
TECHNO220/100	1,8 mt - 5,9 ft	2,2 mt - 7,2 ft	-	150 mm - 6" - OUTLET 180 mm 7" - R	AL-100
TECHNO220/150	1,8 mt - 5,9 ft	2,2 mt - 7,2 ft	-	150 mm - 6" - OUTLET 180 mm 7" - R	AL-150
TECHNO330/100	2,8 mt - 9,2 ft	3,3 mt - 10,9 ft	-	150 mm - 6" - OUTLET 180 mm 7" - R	AL-100
TECHNO330/150	2,8 mt - 9,2 ft	3,3 mt - 10,9 ft	-	150 mm - 6" - OUTLET 180 mm 7" - R	AL-150
TECHNO330/200	2,8 mt - 9,2 ft	3,3 mt - 10,9 ft	-	150 mm - 6" - OUTLET 200 mm 8" - R	AL-200
TECHNO330/300	2,8 mt - 9,2 ft	3,3 mt - 10,9 ft	-	150 mm - 6" - OUTLET 200 mm 8" - R	AL-300
TECHNO420/100	3,6 mt - 11,8 ft	4,2 mt - 13,8 ft	-	150 mm - 6" - OUTLET 180 mm 7" - R	AL-100
TECHNO420/150	3,6 mt - 11,8 ft	4,2 mt - 13,8 ft	-	150 mm - 6" - OUTLET 180 mm 7" - R	AL-150
TECHNO420/200	3,6 mt - 11,8 ft	4,2 mt - 13,8 ft	-	150 mm - 6" - OUTLET 200 mm 8" - R	AL-200
TECHNO420/300	3,6 mt - 11,8 ft	4,2 mt - 13,8 ft	-	150 mm - 6" - OUTLET 200 mm 8" - R	AL-300
TECHNO520/200	4,6 mt - 15,1 ft	5,2 mt - 17,06 ft	-	150 mm - 6" - OUTLET 200 mm 8" - R	AL-200
TECHNO520/300	4,6 mt - 15,1 ft	5,2 mt - 17,06 ft	-	150 mm - 6" - OUTLET 180 mm 7" - R	AL-300
TECHNO630/200	5,6 mt - 18,4 ft	3,3 mt - 10,9 ft	3,0 mt - 9,8 ft	150 mm - 6" - OUTLET 200 mm 8" - R	AL-200
TECHNO630/300	5,6 mt - 18,4 ft	3,3 mt - 10,9 ft	3,0 mt - 9,8 ft	150 mm - 6" - OUTLET 200 mm 8" - R	AL-300
TECHNO720/200	6,6 mt - 21,7 ft	4,2 mt - 13,8 ft	3,0 mt - 9,8 ft	150 mm - 6" - OUTLET 200 mm 8" - R	AL-200
TECHNO720/300	6,6 mt - 21,7 ft	4,2 mt - 13,8 ft	3,0 mt - 9,8 ft	150 mm - 6" - OUTLET 200 mm 8" - R	AL-300
TECHNO830/200	7,6 mt - 25,0 ft	3,3 mt - 10,9 ft	5,0 mt - 16,4 ft	150 mm - 6" - OUTLET 200 mm 8" - R	AL-200
TECHNO830/300	7,6 mt - 25,0 ft	3,3 mt - 10,9 ft	5,0 mt - 16,4 ft	150 mm - 6" - OUTLET 200 mm 8" - R	AL-300
TECHNO920/200	8,6 mt - 28,3 ft	4,2 mt - 13,8 ft	5,0 mt - 16,4 ft	150 mm - 6" - OUTLET 200 mm 8" - R	AL-200
TECHNO920/300	8,6 mt - 28,3 ft	4,2 mt - 13,8 ft	5,0 mt - 16,4 ft	150 mm - 6" - OUTLET 200 mm 8" - R	AL-300

KIT ARMFLEX



 Braccio articolato auto-portante con tubi rigidi in alluminio Ø 160 mm per aspirazione fumi di saldatura. Dotato di staffa di fissaggio a parete e elettroaspiratore.

 Articulated flexible arm Ø 160 mm for welding fume extraction. Equipped with wall bracket and fan.



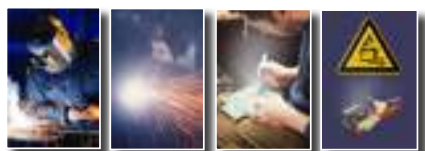

 Bras articulé auto-portant pour l'aspiration des fumées de soudure Ø 160 mm. Prémuni d'une console murale, il est fourni avec hotte à poignée de positionnement et clapet de régulation et aspirateur.

 Selbsttragender Gelenkarm mit Rohren aus Aluminium Ø 160 zur Absaugung von Schweißrauch. Ausgestattet mit Wandbefestigungsbügel und ventilator.

 Brazo articulado autoportante para aspirar humos de soldadura con tubos rígidos de aluminio Ø 160 mm. . Incluye soporte a pared y Aspirador



Dettagli tecnici - Technical details - Données techniques - Technische Daten - Datos Técnicos

Model					
ARMFLEX-330/100	2,8 mt - 9,2 ft	3 mt - 9,1 ft	-	160 mm - 6,3" - OUTLET 180 mm 7" - R	AL-100
ARMFLEX-330/150	2,8 mt - 9,2 ft	3 mt - 9,1 ft	-	160 mm - 6,3" - OUTLET 180 mm 7" - R	AL-150
ARMFLEX-330/200	2,8 mt - 9,2 ft	3 mt - 9,1 ft	-	160 mm - 6,3" - OUTLET 200 mm 8" - R	AL-200
ARMFLEX-330/300	2,8 mt - 9,2 ft	3 mt - 9,1 ft	-	160 mm - 6,3" - OUTLET 200 mm 8" - R	AL-300
ARMFLEX-420/100	3,6 mt - 11,8 ft	4 mt - 13,1 ft	-	160 mm - 6,3" - OUTLET 180 mm 7" - R	AL-100
ARMFLEX-420/150	3,6 mt - 11,8 ft	4 mt - 13,1 ft	-	160 mm - 6,3" - OUTLET 180 mm 7" - R	AL-150
ARMFLEX-420/200	3,6 mt - 11,8 ft	4 mt - 13,1 ft	-	160 mm - 6,3" - OUTLET 200 mm 8" - R	AL-200
ARMFLEX-420/300	3,6 mt - 11,8 ft	4 mt - 13,1 ft	-	160 mm - 6,3" - OUTLET 200 mm 8" - R	AL-300
ARMFLEX-630/200	5,6 mt - 18,4 ft	3 mt - 9,1 ft	3,0 mt - 9,8 ft	160 mm - 6,3" - OUTLET 200 mm 8" - R	AL-200
ARMFLEX-630/300	5,6 mt - 18,4 ft	3 mt - 9,1 ft	3,0 mt - 9,8 ft	160 mm - 6,3" - OUTLET 200 mm 8" - R	AL-300
ARMFLEX-720/200	6,6 mt - 21,7 ft	4 mt - 13,1 ft	3,0 mt - 9,8 ft	160 mm - 6,3" - OUTLET 200 mm 8" - R	AL-200
ARMFLEX-720/300	6,6 mt - 21,7 ft	4 mt - 13,1 ft	3,0 mt - 9,8 ft	160 mm - 6,3" - OUTLET 200 mm 8" - R	AL-300
ARMFLEX-830/200	7,6 mt - 25,0 ft	3 mt - 9,1 ft	5,0 mt - 16,4 ft	160 mm - 6,3" - OUTLET 200 mm 8" - R	AL-200
ARMFLEX-830/300	7,6 mt - 25,0 ft	3 mt - 9,1 ft	5,0 mt - 16,4 ft	160 mm - 6,3" - OUTLET 200 mm 8" - R	AL-300
ARMFLEX-920/200	8,6 mt - 28,3 ft	4 mt - 13,1 ft	5,0 mt - 16,4 ft	160 mm - 6,3" - OUTLET 200 mm 8" - R	AL-200
ARMFLEX-920/300	8,6 mt - 28,3 ft	4 mt - 13,1 ft	5,0 mt - 16,4 ft	160 mm - 6,3" - OUTLET 200 mm 8" - R	AL-300

KIT TECHNO 2



Bracci articolati auto-portanti con tubi rigidi in alluminio Ø 150 mm per aspirazione fumi di saldatura. Dotato di staffa di fissaggio a parete.



Fume extraction kit consisting of two articulated Techno arms Ø 150 mm in various lengths and with fan included.



Bras articulés debout tuyau rigide en aluminium Ø 150 mm pour le soudage. Extraction des fumées Il a équipé avec support pour le montage mural.



Gelenkarme stand Rohr steife Aluminium Ø 150 mm für Schweißrauchabsaugung. Ausgestattet mit Halterung für die Wandmontage.



Brazos articulados Tubo Ø aluminio rígido de pie 150 mm para la soldadura de extracción de humos. Se cuenta con el soporte de montaje en la pared.

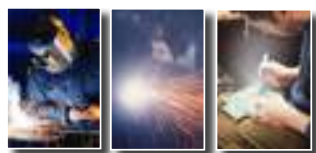

Model				
TECHNO-2-220/300	1,8 mt - 5,9 ft	2,2 mt - 7,2 ft	150 mm - 6" - OUTLET 200 mm 8" - R	AL-300
TECHNO-2-330/300	2,8 mt - 9,2 ft	3,3 mt - 10,9 ft	150 mm - 6" - OUTLET 200 mm 8" - R	AL-300
TECHNO-2-420/300	3,6 mt - 11,8 ft	4,2 mt - 13,8 ft	150 mm - 6" - OUTLET 200 mm 8" - R	AL-300

KIT DYNAMIC



Braccio articolato auto-portante con tubi rigidi in alluminio da Ø 100 mm a 200 mm per aspirazione fumi di saldatura. Dotato di ralla per rotazione a 360°, ma senza staffa a parete (DYNAMIC-210 senza ralla).



Articulated arm with rigid aluminium pipes from Ø 100 mm to 200 mm for welding fume extraction. Equipped with swivel for a 360° rotation. Without wall bracket. (DYNAMIC-210 without rotary bearing).



Bras articulé autoportant avec tuyau rigide en aluminium de Ø 100 mm a 200 mm pour l'aspiration de fumées de soudure. Il est fourni avec un tourillon pour une rotation de 360°. Support murale pas inclus (DYNAMIC-210 sans rotule).



Selbsttragender Gelenkarm mit Rohren aus Aluminium Ø 100, Ø 200 zur Absaugung von Schweißrauch. Ausgestattet mit Anlaufscheibe zur Drehung von 360° (DYNAMIC-210 ohne drehflansch).



Brazo articulado autoportante con tubos rígidos de aluminio desde Ø 100 mm a Ø 200 mm para aspirar humos de soldadura. Están dotados de rotula de rotación de 360°, necesitan de soporte para jación a pared (DYNAMIC-210 sin chumaquera).

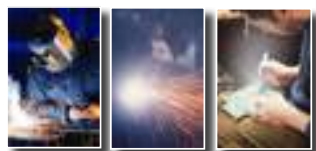



Model				
DYNAMIC-210/50	1,7 mt - 5 ft	2 mt - 6 ft	100 mm - 4"	AL-50
DYNAMIC-210/100	1,7 mt - 5 ft	2 mt - 6 ft	100 mm - 4"	AL-100
DYNAMIC-270/50	2,5 mt - 8,2 ft	2,7 mt - 8,10 ft	100 mm - 4"	AL-50
DYNAMIC-270/100	2,5 mt - 8,2 ft	2,7 mt - 8,10 ft	100 mm - 4"	AL-100
DYNAMIC-350/200	2,7 mt - 8,10 ft	2,8 mt - 9 ft	200 mm - 8"	AL-200
DYNAMIC-350/300	2,7 mt - 8,10 ft	2,8 mt - 9 ft	200 mm - 8"	AL-300
DYNAMIC-470/200	3,5 mt - 11,5 ft	3,5 mt - 11,5 ft	200 mm - 8"	AL-200
DYNAMIC-470/300	3,5 mt - 11,5 ft	3,5 mt - 11,5 ft	200 mm - 8"	AL-300

KIT TECHNOSTAR



 Kit di aspirazione fumi composto da braccio articolato in varie lunghezze e aspiratore in lamiera d'acciaio direttamente accoppiato ad un filtro ad abbattimento meccanico mod. STARFILTER.

 Fume extraction kit consisting of an articulated arm in various different lengths and a sheet steel extractor coupled directly to a STARFILTER mechanical filtering unit.

 Kit d'aspiration fumées constitué d'un bras articulé en différentes longueurs et d'un ventilateur en tôle d'acier directement assemblé à un filtre à filtration mécanique mod. STARFILTER.

 Rauchabsaugungskit bestehend aus Gelenkarm in verschiedenen Längen und direkt mit einem mechanischen Abscheidefilter Mod. STARFILTER verbundenem Absauger aus Stahlblech.

 Kit de aspiración de humos compuesto por un brazo articulado con varias longitudes disponibles, aspirador de chapa de acero incorporado y filtro mecánico mod. STARFILTER.









STAR-2000-SPS / STAR-4000-SPS



STAR-2000-FU / STAR-4000-FU



Dettagli tecnici - Technical details - Données techniques - Technische Daten - Datos Técnicos

Model													
TECHNOSTAR-2000/2	1,8 mt - 5,9 ft	2,2 mt - 7,2 ft	150 mm - 6" OUTLET 200 mm 8" - R	AL-200	STAR-2000	2000 m ³ /h	1176 c.f.m.	95 %	1200 H				
TECHNOSTAR-2000/3	1,8 mt - 5,9 ft	3,3 mt - 10,9 ft	150 mm - 6" OUTLET 200 mm 8" - R	AL-200	STAR-2000	2000 m ³ /h	1176 c.f.m.	95 %	1200 H				
TECHNOSTAR-2000/4	3,6 mt - 11,8 ft	4,2 mt - 13,8 ft	150 mm - 6" OUTLET 200 mm 8" - R	AL-200	STAR-2000	2000 m ³ /h	1176 c.f.m.	95 %	1200 H				
TECHNOSTAR-4000/2	1,8 mt - 5,9 ft	2,2 mt - 7,2 ft	150 mm - 6" OUTLET 200 mm 8" - R	AL-200	STAR-4000	4000 m ³ /h	2352 c.f.m.	95 %	2000 H				
TECHNOSTAR-4000/3	1,8 mt - 5,9 ft	3,3 mt - 10,9 ft	150 mm - 6" OUTLET 200 mm 8" - R	AL-200	STAR-4000	4000 m ³ /h	2352 c.f.m.	95 %	2000 H				
TECHNOSTAR-4000/4	3,6 mt - 11,8 ft	4,2 mt - 13,8 ft	150 mm - 6" OUTLET 200 mm 8" - R	AL-200	STAR-4000	4000 m ³ /h	2352 c.f.m.	95 %	2000 H				



Kit per l'aspirazione e l'evacuazione di esalazioni e odori nocivi nella l'ambiente di lavoro. Il kit ASPIRVAPOR è dotato di cappa in vetroresina 1000x1200, flessibile di collegamento Ø 120 e elettroaspiratore in fusione Mod. AS-75/C. Occorre prevedere sistema di fissaggio della cappa, in base alle esigenze del cliente.



Extracting and expulsiing kit suitable for exhalations and harmful odors in the working places. ASPIRVAPOR kit has a fiberglass hood 1000x1200, connecting hose Ø 120 and aluminium fan AK-75. An hood holder should be contemplate according to the customer needs.



Kit pour l'aspiration et l'évacuation de fumées et gaz nocifs depuis la zone de travail. Le kit ASPIRVAPOR est équipée de hotte aspirante en fibre de verre 1000x1200, tuyau flexible de raccordement Ø120 et ventilateur en fusion Mod. AS-75/C. Il faut prévoir un système de support de la hotte, selon les besoins du client.



Kit für die Absaugung und das Abführen von schädlichen Gasen und Dämpfe aus der Arbeitsumgebung. Das Kit ASPIRVAPOR ist mit einer Fiberglas Absaughaube 1000x1200, Verbindungschlauch Ø120 und Ventilator Mod. AS-75/C ausgestattet. Man sollte ein Befestigungssystem der Haube vorzusehen, nach Kundenwunsch.



Kit para la aspiracion y expulsion de las exhalaciones y malos olores en las zonas de trabajo. El Kit ASPIRVAPOR lleva una campana en fibra de vidrio 1000x1200, una manguera de diametro 120 y un electroaspirador Mod. AS-75/C. Hay que estudiar un sistema de anclaje en relacion a las necesidades del cliente.



ASPIRVAPOR

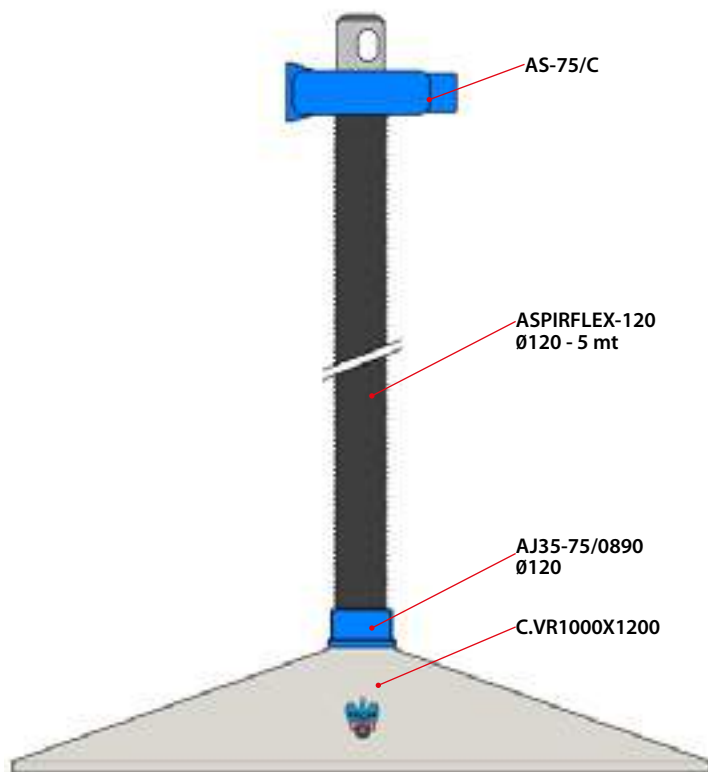

Accessori - Accessories - Accessoires - Zubehör - Accesorios

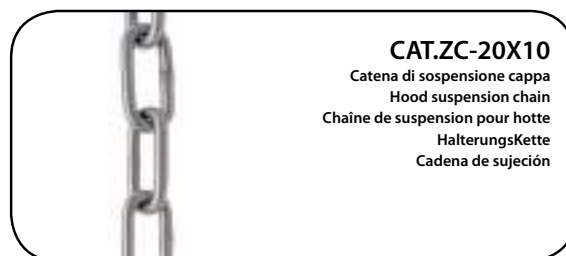
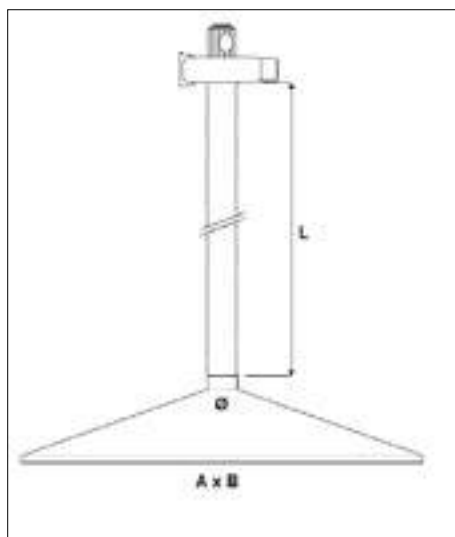

CAT.ZC-20X10
 Catena di sospensione cappa
 Hood suspension chain
 Chaîne de suspension pour hotte
 Halterungskette
 Cadena de sujeción



4 x DIN580-M8-Z
 Golfari per catena
 Hooks for chain
 Suspensions pour chaîne
 Halterungen für Kette
 Enganches para cadena

Dettagli tecnici - Technical details - Données techniques - Technishe Daten - Datos Técnicos

Model	A x B	L	Ø	HP	kW	phases	V	Hz	m ³ /h	c.f.m.	Antidef.
ASPIRVAPOR-75	1000 x 1200	5 mt	120	0,75	0,55	3P+T	230-400	50	800	412	-
ASPIRVAPOR-75M	1000 x 1200	5 mt	120	0,75	0,55	1 P+N+T	230	50	800	412	-
ASPIRVAPOR-75A	1000 x 1200	5 mt	120	0,75	0,55	3P+T	230-400	50	800	412	SPARKPROOF

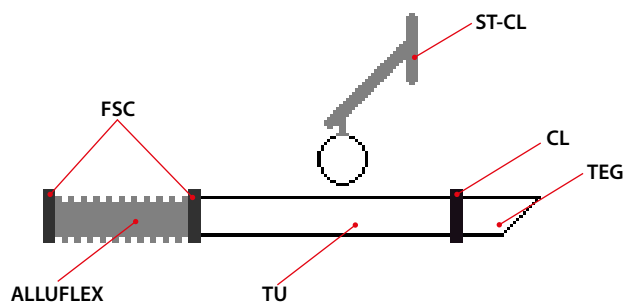

Model
CAMINO-01-150 ; L= 2 mt
CAMINO-01-180 ; L= 2 mt
CAMINO-01-200 ; L= 2 mt

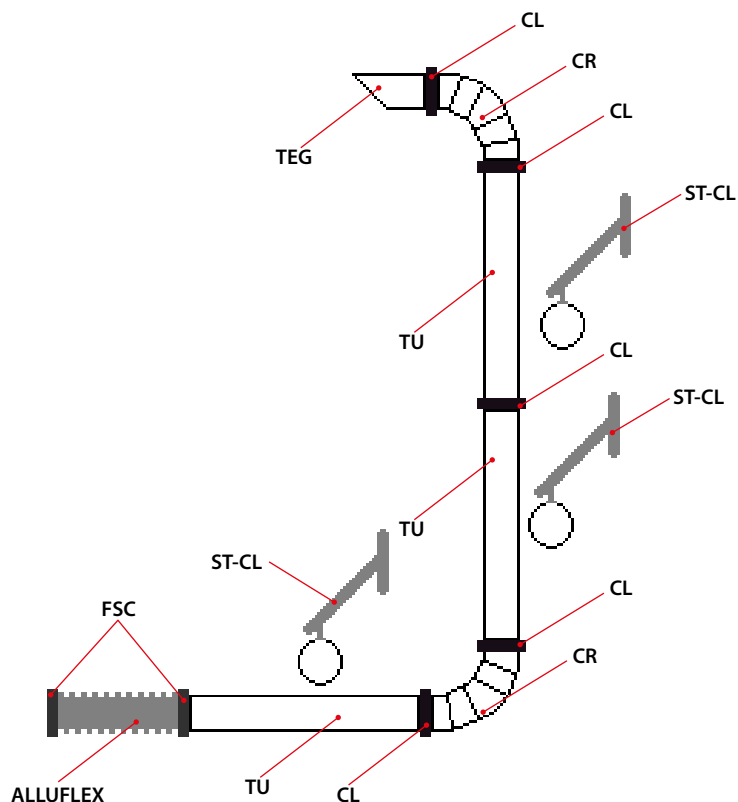

Model
CAMINO-02-150 ; L= 5 mt
CAMINO-02-180 ; L= 5 mt
CAMINO-02-200 ; L= 5 mt

KIT CAMINO

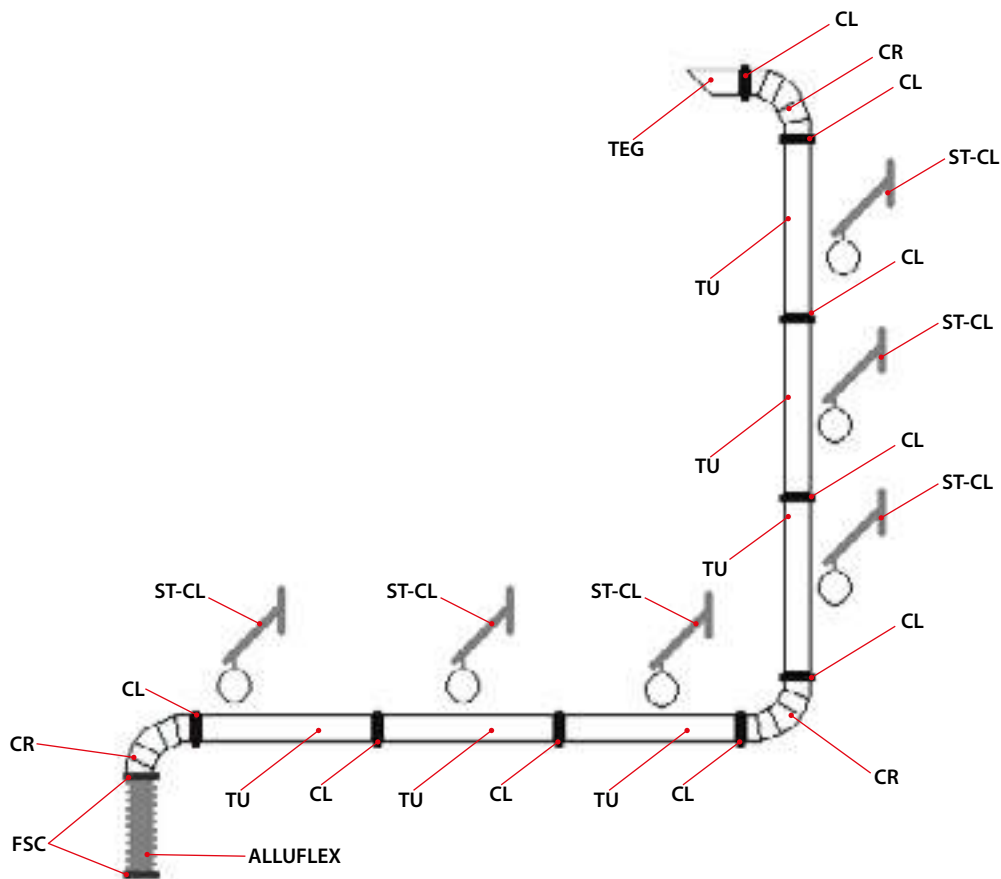

Model
CAMINO-03-150 ; L= 10 mt
CAMINO-03-180 ; L= 10 mt
CAMINO-03-200 ; L= 10 mt

ESEMPI DI INSTALLAZIONE - INSTALLATION EXAMPLES - EXEMPLES D'INSTALLATION - EINBAUBEISPIELE - EJEMPLOS DE INSTALACIÓN





www.filcar.eu

ARREDO TECNICO



TECHNICAL CABINETS
MOBILEIER D'ATELIER
TECHNISCHE AUSSTATTUNG
MUBLES TECNICOS



↑ H 900 mm

→ W 2010 mm

↗ D 670 mm

ALLESTIMENTO 1/ COMPOSITION 1/ COMPOSITION 1/ AUFBAUV 1 / COMPOSICIÓN 1



COMPOSIZIONE D'ARREDO COMPOSTA DA: 2. Cassettiera fissa con 5 cassetti, chiusura chiave, piedi regolabili, maniglia in acciaio inox, guide da 45 kg cad. a cassetto. 1. Piana di lavoro in robusto acciaio verniciato, con rivestimento in NBR antigraffio e antiacido.



COMPOSITION OF TECHNICAL FURNITURE INCLUDING: 2 cabinets with 5 drawers each (2x H 65 mm, 2x H135 mm, 1 x H 275), key lock, adjustable feet, handle in stainless steel, guides, 45 kg for each drawer. One working top in sturdy painted steel, covered by scratch-resistant and acid-resistant NBR.



COMPOSITION DE MOBILIER D'ATELIER QUI COMPREND: 2. modules fixes avec 5 tiroirs (2x H 65 mm, 2x H135 mm, 1 x H 275), serrure à clé, pieds réglables, poignée en acier inoxydable, guides de 45 kg pour chaque tiroir. 1. plan de travail en robuste acier peint, avec revêtement en NBR résistant aux rayures et à l'acide.



Komposition bestehend aus: 2 x Kommode, je mit 5 Schubladen (2x H 65 mm, 2x H135 mm, 1 x H 275), Verriegelung mit Schlüssell, Höhenverstellbaren Fuessen, Griff aus Edelstahl, Tragfaehigkeit per Schublade 45 Kg. 1 x Arbeitstop aus lackierte Stahlblech mit NBR Kratz-Saeurebestaendigsabdeckung.



COMPOSICIÓN DE MUEBLES TÉCNICOS COMPUESTA POR: 2 cajoneras fijas con 5 cajones (2x H 65 mm, 2x H135 mm, 1 x H 275), cierre con llave, patas regulable, manillas en acero INOX, guías de 45 kg cada cajón. 1 plano de trabajo en chapa de acero barnizado en polvo, con cobertura en NBR anti rayado y anti ácidos.

ALLESTIMENTO 2/ COMPOSITION 2/ COMPOSITION 2/ AUFBAUV 2 / COMPOSICIÓN 2



↑ H 900 mm

→ W 2010 mm

↗ D 670 mm



COMPOSIZIONE D'ARREDO COMPOSTA DA: 1. Armadio con anta, due ripiani interni, chiusura con chiave, piedi regolabili e maniglia in acciaio inox. 1. Cassettiera fissa con 5 cassetti, chiusura chiave, piedi regolabili, maniglia in acciaio inox, guide da 45 kg cad. a cassetto. 1. Piana di lavoro in robusto acciaio verniciato, con rivestimento in NBR antigraffio e antiacido.



COMPOSITION OF TECHNICAL FURNITURE INCLUDING: One cabinet with door, two shelves, key lock, adjustable feet and handle in stainless steel. One cabinet with 5 drawers, lockable, adjustable feet, handle in stainless steel, guides, 45 kg for each drawer. One working top in sturdy painted steel, covered by scratch-resistant and acid-resistant NBR.



COMPOSITION DE MOBILIER D'ATELIER QUI COMPREND: 1. Armoire avec porte, deux étagères, serrure à clé, pieds réglables et poignée en acier inoxydable. 1. Module fixe avec 5 tiroirs, pieds réglables, poignée en acier inoxydable, guides de 45 kg pour chaque tiroir. 1. plan de travail en robuste acier peint, avec revêtement en NBR résistant aux rayures et à l'acide.



Komposition bestehend aus: 1 x Schrank mit 2 Regale, Verriegelung mit Schlüssell, Höhenverstellbaren Fuessen, Griff aus Edelstahl. 1 x Kommode mit 5 Schubladen, Verriegelung mit Schlüssell, Höhenverstellbaren Fuessen, Griff aus Edelstahl, Tragfaehigkeit per Schublade 45 Kg. 1 x Arbeitstop aus lackierte Stahlblech mit NBR Kratz-Saeurebestaendigsabdeckung.



COMPOSICIÓN DE MUEBLES TÉCNICOS COMPUESTA POR: 1. Armario con puerta con 2 baldas internas, cierre con llave, patas regulable y manillas en acero INOX - 1. Cajonera fija con 5 cajones (2x H 65 mm, 2x H135 mm, 1 x H 275), cierre con llave, patas regulable, manillas en acero INOX, guías de 45 kg cada cajón. 1 plano de trabajo en chapa de acero barnizado en polvo, con cobertura en NBR anti rayado y anti ácidos.

ALLESTIMENTO 3/ COMPOSITION 3/ COMPOSITION 3/ AUFBAUV 3 / COMPOSICIÓN 3



↑ H 900 mm

→ W 2010 mm

↗ D 670 mm



COMPOSIZIONE D'ARREDO COMPOSTA DA: 2. Armadio con anta, due ripiani interni, chiusura con chiave, piedi regolabili e maniglia in acciaio inox. 1. Piana di lavoro in robusto acciaio verniciato, con rivestimento in NBR antigraffio e antiacido.



COMPOSITION OF TECHNICAL FURNITURE INCLUDING: 2 Cabinets with doors, two shelves, key lock, adjustable feet and handle in stainless steel. One working top in sturdy painted steel, covered by scratch-resistant and acid-resistant NBR.



COMPOSITION DE MOBILIER D'ATELIER QUI COMPREND: 2. armoire avec porte, deux étagères, serrure à clé, pieds réglables et poignée en acier inoxydable. 1. robuste acier peint, avec revêtement en NBR résistant aux rayures et à l'acide.



Komposition bestehend aus: 2 x Schraenke je mit 2 Regale, Verriegelung mit Schlüssell, Höhenverstellbaren Fuessen, Griff aus Edelstahl. 1 x Arbeitstop aus lackierte Stahlblech mit NBR Kratz-Saeurebestaendigsabdeckung.







COMPOSICIÓN DE MUEBLES TÉCNICOS COMPUESTA POR: 2. armarios con puerta con 2 baldas internas, cierre con llave, patas regulable y manillas en acero INOX - 1 plano de trabajo en chapa de acero barnizado en polvo, con cobertura en NBR anti rayado y anti ácidos.



↑ H 1675 mm
→ W 670 mm
↗ D 670 mm





KOMBO AR

-  KOMBO composto da moduli di arredo. 1 Cassettiera fissa con 5 cassetti, chiusura chiave, piedi regolabili, maniglia in acciaio inox, guide da 45 kg cad. a cassetto. 1. Armadio con anta, due ripiani interni, chiusura con chiave, piedi regolabili e maniglia in acciaio inox.
-  It composed of furniture modules. One cabinet with 5 drawers, lockable, adjustable feet, handle in stainless steel, guides, 45 kg for each drawer. One cabinet with door, two shelves, key lock, adjustable feet and handle in stainless steel.
-  Il a composé de modules de meubles. 1. Armoire avec porte, deux étagères, serrure à clé, pieds réglables et poignée en acier inoxydable. 1. Module fixe avec 5 tiroirs, pieds réglables, poignée en acier inoxydable, guides de 45 kg pour chaque tiroir.
-  Es besteht aus Möbelmodule. 1 x Kommode mit 5 Schubladen, Verriegelung mit Schlüssel, Höhenverstellbaren Fuessen, Griff aus Edelstahl, Tragfaehigkeit per Schublade 45 Kg. 1. 1 x Schrank mit 2 Regale, Verriegelung mit Schluessel, Hoehenverstellbaren Fuessen, Griff aus Edelstahl.
-  Se compone de módulos de muebles. Cajonera fija con 5 cajones (2x H 65 mm, 2x H135 mm, 1 x H 275), cierre con llave, patas regulable, manillas en acero INOX, guías de 45 kg cada cajón. 1. Armario con puerta con 2 baldas internas, cierre con llave, patas regulable y manillas en acero INOX.

OPTIONAL



↑ H 960 mm
→ W 2010 mm
↗ D 255 mm

-  Sulle composizioni di arredo è possibile inserire un pratico porta utensili di robusta struttura in lamiera d'acciaio verniciata a polvere, serrandina in alluminio con incavo maniglia, serratura con chiave e pannello posteriore con scassi a toppa di chiave (su richiesta disponibile anche in versione con fori quadrati).
-  It is possible to put a sturdy tools holder on the top of technical furniture composition solid sheet steel with powder coating structure, aluminium roll-up shutter with hollow handle, key-lock with key, rear panel with keyhole cut-outs (on request also available with square holes).
-  Dans les compositions de mobilier d'atelier il est possible d'insérer un module porte-outils avec une structure robuste en tôle d'acier avec revêtements en poudre, serrure en aluminium avec poignée creuse, serrure à clé, panneau arrière avec découpes en trou de serrure (sur demande également disponible avec des trous carrés).
-  Auf die Einrichtungsmodule kann man ein Werkzeugtagel mit Rollladen montieren robuste struktur aus pulverlackiert stahlblech, aluminium-Rollladen mit integrierte Griff, schlüsselschloss, rückwand mit Schlüssellochausschnitte (auf Wunsch auch mit karierte Löchern verfügbar).
-  Encima a las composiciones es posible poner un tablero porta utensilios en solida chapa de acero barnizada en polvo, estructura en solida chapa de acero barnizada en polvo, persiana en aluminio con hueco para manilla, cierre con llave, tablero posterior con agujeros a forma de cerradura (disponible tambien con agujeros a forma cuadrada).



Light



HD



Light



Saldatura a stagno, puntatura, o saldatura leggera per massimo 2 ore giornaliere sviluppata in intervalli brevi. Amperaggio e fumosità bassa. Deodorazione dell'aria filtrata.

Saldatura ossiacetilénica, ad elettrodo o MIG/MAG per brevi intervalli. Amperaggio e fumosità media. Deodorazione dell'aria filtrata.

Saldatura ossiacetilénica, ad elettrodo o MIG/MAG, TIG per brevi intervalli. Amperaggio e fumosità medio/alta. Deodorazione dell'aria filtrata.

Aspirazione e filtrazione di nebbie oleose prodotte dall'evaporazione di emulsioni di raffreddamento. Adatta ad applicazioni su macchine a controllo numerico.

Saldatura ossiacetilénica, ad elettrodo o MIG/MAG, TIG per brevi intervalli. Smerigliatura e produzione di polvere in sospensione. Amperaggio e fumosità bassa. Aria filtrata non deodorata.

Saldatura ossiacetilénica, ad elettrodo o MIG/MAG, TIG per brevi intervalli. Smerigliatura e produzione di polvere in sospensione. Amperaggio e fumosità media. Aria filtrata non deodorata.



Maximum of 2 hours soldering, light welding or spot welding per day, in short periods. Low current consumption and fume generation. Filtered air is deodorised.

Oxyacetylene, electrode or MIG/MAG welding for short periods. Low current consumption and fume generation. Filtered air is deodorised.

Oxyacetylene, electrode or MIG/MAG, TIG welding for short periods. Medium/high current consumption and fume generation. Filtered air is deodorised.

Extraction and filtration of oil mists produced by CNC machines' cooling fluids.

Oxyacetylene, electrode or MIG/MAG, TIG welding for short periods. Grinding and suspended dust. Small current consumption and fume generation. Filtered air is not deodorised.

Oxyacetylene, electrode or MIG/MAG, TIG welding for short periods. Grinding and suspended dust. Medium current consumption and fume generation. Filtered air is not deodorised.



Soudure à l'étain, pointage ou soudure légère pendant 2 heures par jour maximum, réalisée sur de courts intervalles. Ampérage et fumosité faibles. Désodorisation de l'air filtré.

Soudure oxyacétylénique, à électrode ou MIG/MAG sur de courts intervalles. Ampérage et fumosité moyens. Désodorisation de l'air filtré.

Soudure oxyacétylénique, à électrode ou MIG/MAG, TIG sur de courts intervalles. Ampérage et fumosité moyen/élevée. Désodorisation de l'air filtré.

Aspiration et filtration de brouillards d'huile produits de l'évaporation d'émulsion de refroidissement. Ce système est adapté pour des applications sur les machines à contrôle numérique.

Soudure oxyacétylénique, à électrode ou MIG/MAG, TIG sur de courts intervalles. Meulage et production de poussière en suspension. Ampérage et fumosité faibles. Air filtré non désodorisé.

Soudure oxyacétylénique, à électrode ou MIG/MAG, TIG sur de courts intervalles. Meulage et production de poussière en suspension. Ampérage et fumosité moyen. Air filtré non désodorisé.



W e i c h l ö t e n , Heftschiessen oder leichtere Schweißarbeiten für maximal 2 Stunden täglich in kurzen Intervallen. Niedrige Stromstärke und Rauchentwicklung. Geruchsbeseitigung der gefilterten Luft.

Gasschmelzschweißen, Elektrodenschweißen oder MIG/MAG-Schweißen für kurze Intervalle. Mittlere Stromstärke und Rauchentwicklung. Geruchsbeseitigung der gefilterten Luft.

Gasschmelzschweißen, Elektrodenschweißen oder MIG-/MAG-/TIG-Schweißen für kurze Intervalle. Mittlere/hohe Stromstärke und Rauchentwicklung. Geruchsbeseitigung der gefilterten Luft.

Absaugung und Filtrierung von Ölnebel, das von Abkühlungsemulsionen verursacht sind. Bestimmt für Verwendung auf Zahlenregelungsmaschinen.

Gasschmelzschweißen, Elektrodenschweißen oder MIG-/MAG-/WIG-Schweißen für kurze Intervalle. Schleifen und Erzeugung von Schwebstäuben. Niedrige Stromstärke und Rauchentwicklung. Gefilterte Luft nicht geruchsneutralisiert.

Gasschmelzschweißen, Elektrodenschweißen oder MIG-/MAG-/WIG-Schweißen für kurze Intervalle. Schleifen und Erzeugung von Schwebstäuben. Mittlere Stromstärke und Rauchentwicklung. Gefilterte Luft nicht geruchsneutralisiert.



Soldadura con estaño, por puntos o ligera para un máximo de 2 horas diarias a intervalos cortos. Amperaje y nivel de humo bajo. Desodorización del aire filtrado.

Soldadura oxiacetilénica con electrodo o MIG/MAG a intervalos cortos. Amperaje y nivel de humo medio. Desodorización del aire filtrado.

Soldadura oxiacetilénica con electrodo o MIG/MAG, TIG a intervalos cortos. Amperaje y nivel de humo medio/alto. Desodorización del aire filtrado.

Aspiración y filtración de neblina de aceite producida por la evaporación de emulsiones de enfriamiento. Apropriado para aplicaciones en maquinas a control numerico.

Soldadura oxiacetilénica con electrodo o MIG/MAG, TIG a intervalos cortos. Esmerilado y producción de polvos en suspensión. Amperaje y nivel de humo bajo. Aire filtrado sin desodorización.

Soldadura oxiacetilénica con electrodo o MIG/MAG, TIG a intervalos cortos. Esmerilado y producción de polvos en suspensión. Amperaje y nivel de humo medio. Aire filtrado sin desodorización.

LEGEND

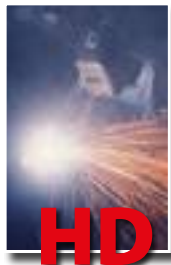

Saldatura ossiacetilénica, ad elettrodo o MIG/MAG, TIG per brevi intervalli. Smerigliatura e produzione di polvere in sospensione. Amperaggio e fumosità alta. Aria filtrata non deodorata.

Saldatura a stagno, puntatura leggera per massimo 1 ora giornaliera sviluppata in intervalli brevi. Amperaggio e fumosità bassa. Deodorazione dell'aria filtrata.

Estrazione di gas tossici, vapori, nebbie e sospensioni poco polverose ma comunque non infiammabili o potenzialmente esplosive.



Oxyacetylene, electrode or MIG/MAG, TIG welding for short periods. Grinding and suspended dust. High current consumption and fume generation. Filtered air is not deodorised.

Maximum of 1 hour soldering, light welding or spot welding per day, in short periods. Low current consumption and fume generation. Filtered air is deodorised.

Extraction of toxic gases, vapours, mists, and suspensions that have a low dust content but are still inflammable or potentially explosive.



Soudure oxyacétylénique, à électrode ou MIG/MAG, TIG sur de courts intervalles. Meulage et production de poussière en suspension. Ampérage et fumosité élevée. Air filtré non désodorisé.

Soudure à l'étain, pointage léger pour 1 heure par jour maximum, réalisée sur de courts intervalles. Ampérage et fumosité faibles. Désodorisation de l'air filtré.

Extraction de gaz toxiques, vapeurs, brouillards et suspensions peu poussiéreuses mais toujours non inflammables ou potentiellement explosives.



Gasschmelzschweißen, Elektrodenschweißen oder MIG-/MAG-/WIG-Schweißen für kurze Intervalle. Schleifen und Erzeugung von Schwebstäuben. Hohe Stromstärke und Rauchentwicklung. Gefilterte Luft nicht geruchsneutralisiert.

Weichlöten, leichte Schweißarbeiten für höchstens 1 Stunde am Tag in kurzen Intervallen. Geeignet für niedrige Stromstärke und Rauch. Geruchsbeseitigung der filterten Luft.

Abführen von giftigen Gasen, Dämpfen, nicht entflammaren oder potentiell explosiven Nebeln und Aerosole mit geringer Staubbelastung.



Soldadura oxiacetilénica con electrodo o MIG/MAG, TIG a intervalos cortos. Esmerilado y producción de polvos en suspensión. Amperaje y nivel de humo alto. Aire filtrado sin desodorización.

Soldadura con estaño, por puntos, ligera para 1 hora diaria a intervalos cortos. Amperaje y nivel de humo bajo. Desodorización del aire filtrado.

Extracción de gases tóxicos, vapores, nieblas y partículas en suspensión con bajo contenido de polvo, no inflamables ni potencialmente explosivos.

Filcar Spa è certificata ISO-9001:2008

Filcar Spa is a ISO-9001:2008 certified company

Filcar S.p.A. est certifiée ISO-9001 : 2008

Filcar SpA ist nach ISO-9001:2008 zertifiziert

Filcar Spa tiene la certificación ISO-9001:2008



INDICE PER ARTICOLO



INDEX BY ITEM - INDEX DES ARTICLES - ARTIKELVERZEICHNIS - INDICE POR ARTICULO

CODE	PAG
AL	62
ARMFLEX	8
AS	64
ASPIRVAPOR	76
BOX-INS	67
BSAN	51
BSN	50
BSJET-DF	52
BSWELD	53
CLOUD-CAP	14
CV	67
CZ-CZ1	56
CZ2-CZ3	57
DYNAMIC	12
ECOMINOR	22
ECOMINOR-C	23
ECOMINOR-FLEX	20
ECOMINOR-FLEX-C	21
EM-AL	16
FILTER-CARBON	40
FILTERJET	42
GNT	67
INT	69
MASTER	24

CODE	PAG
MASTERJET-DF2	28
ME	67
MINI90-NEW	18
MINIJET-DF	26
NOIL	46
OIL-GAMM	44
QE-AC	69/70
SET-PIEDINI	67
STARFILTER	38
SUPERJET-DF	32
SUPERJET-DF9PLUS	34
TECHNO	6
TECHNOFLEX	10
XTK1-XTK2	58
KIT-ARMFLEX	73
KIT-CAMINO-01/02/03	78
KIT-DYNAMIC	74
KIT-TECHNO	72
KIT-TECHNO-2	74
KIT-TECHNOSTAR	75



I dati tecnici riportati nel presente catalogo sono quelli al momento in possesso della Filcar S.p.A., la quale si riserva il diritto di apportare in ogni momento, senza preavviso, migliorie o modifiche ai suoi prodotti. Le informazioni, illustrazioni e dati tecnici contenuti nei cataloghi, manuali, listini, ecc. hanno carattere informativo e non impegnativo.



The technical data given in this catalogue are those presently in the hands of Filcar S.p.A. S.p.A. The manufacturer reserves the right to add modifications or improvements to its products at any time without notice. The information, illustrations and technical data given in the catalogues, manuals, price lists and so on are merely informative and are not binding.



Les caractéristiques techniques indiquées dans le présent catalogue sont celles que la Société Filcar S.p.A. possèdent pour l'instant. Cette dernière se réserve le droit d'apporter, à tout moment et sans préavis, des améliorations ou des modifications à ses produits. Les informations, les illustrations et les caractéristiques techniques contenues dans les catalogues, les notices, les tarifs, etc., sont fournies à titre d'information et n'engagent pas le fabricant.



Bei den im vorliegenden Katalog aufgeführten technischen Daten handelt es sich um die derzeit der Firma Filcar S.p.A. zur Verfügung stehenden Angaben. Die Firma Filcar S.p.A. behält sich das Recht vor, ohne vorherige Ankündigung, jederzeit Verbesserungen oder Änderungen an ihren Produkten anzubringen. Die in den Katalogen, Handbüchern, Listen, usw. enthalten Informationen, Abbildungen und technischen Daten sind rein informativ und nicht bindend.



Los datos técnicos indicados en el presente catálogo son los que Filcar S.p.A. poseía al momento. La empresa se reserva el derecho de aportar en cualquier momento, sin previo aviso, mejoras o modificaciones a sus productos. Las informaciones, ilustraciones y datos técnicos contenidos en los catálogos, manuales, listados, etc., tienen carácter informativo y no son están sujetos a compromiso alguno.



APPLICATIONS



CODE	SALDATURA (A)		MOLATURA (B) SMERIGLIATURA (C)		ODORI ED ESALAZIONI (G)	LAVORAZIONE SU VETRORESINA (H)	NEBBIE OLEOSE (I)
	ACCIAIO (D)	ALLUMINIO (E)	ACCIAIO (D)	ALLUMINIO (E)	COLLE, VERNICI (F)		
ARMFLEX	✓	✓	X	X	✓	X	✓
ASPIRVAPOR	X	X	X	X	✓	X	X
BSAN-BSN	✓	✓	✓	X	X	X	X
BSJET-DF	✓	✓	✓	X	X	✓	X
BSWELD	✓	✓	X	X	X	X	X
DYNAMIC	✓	✓	✓	X	✓	✓	✓
ECOMINOR	✓	X	X	X	X	X	X
ECOMINOR-C	✓	X	X	X	✓	X	X
ECOMINOR-CARB	✓	X	X	X	✓	X	X
ECOMINOR-FLEX	✓	X	X	X	✓	X	X
ECOMINOR-FLEX-C	✓	X	X	X	✓	X	X
FILTER-CARBON	✓	X	✓	X	✓	X	X
FILTERJET	✓	✓	✓	X	✓	✓	X
MASTER	✓	X	X	X	✓	X	X
MASTERJET-DF2	✓	✓	✓	X	X	✓	X
MINI90-NEW	✓	X	X	X	✓	X	X
MINIJET-DF	✓	✓	✓	X	X	✓	X
NOIL	X	X	X	X	X	X	✓
OIL-GAMM	X	X	X	X	X	X	✓
STARFILTER	✓	X	X	X	✓	X	X
SUPERJET-DF	✓	✓	✓	X	X	✓	X
SUPERJET DF9PLUS	✓	✓	✓	X	X	✓	X
TECHNO	✓	✓	✓	X	✓	✓	✓
TECHNOFLEX	✓	✓	✓	X	X	✓	X

(A)		WELDING	(B)		GRINDING	(C)		GRINDING	(D)		STEEL
		SOUDEGE			MEULAGE			RECTIFICATION			ACIER
		WELDING			SCHLEIFMASCHINEN			SCHLEIFEN			STEEL
		SOLDADURA			MOLIENDA			MOLIENDA			ACERO

(E)		ALUMINIUM
		ALUMINIUM
		ALUMINIUM
		ALUMINIO

(F)		SMELL AND FUMES
		ODEUR ET VAPEURS
		GERUCH UND RAUCH
		OLOR Y HUMOS

(G)		GLUE, PAINT
		COLLE, DE PEINTURE
		LEIM, FARBE
		PEGAMENTO, PINTURA

(H)		WORKING ON FIBERGLASS
		TRAVAIL SUR FIBRE
		ARBEITEN AN FIBERGLAS
		TRABAJO EN FIBRA DE VIDRIO

(I)		MIST OILY
		OIL MIST
		ÖLNEBEL
		ACEITE DE NIEBLA

Catalogo aspirazione fumi di saldatura

Welding fume extraction catalogue

Catalogue aspiration des fumée de soudure

Schweisrauchabsaugungskatalog

Catálogo aspiración de humo de soldadura

FILCAR S.p.A.

via G. Balla, 18
42124

REGGIO EMILIA
ITALY

Tel. +39-0522-941881

Fax. +39-0522-942291

Tel. +39-0522-941167

Fax. +39-0522-494035

www.filcar.eu
commit@filcar.it
export@filcar.it

FILCAR S.A.R.L.

71, Rue de Malacombe
38070 - ST. QUENTIN
FALLAVIER - LYON

FRANCE

Tel. +33-0474-944064

Fax. +33-0474-942931

www.filcar.fr
contact@filcar.fr