

VOLUME MAX 1.800 m³/h - 940 c.f.m.



Canalina in alluminio con sezione 180x200 mm per alloggiamento di unità scorrevoli atte all'evacuazione dei gas di scarico e fumi dagli ambienti di lavoro.

Aluminium track with section 180x200 mm for sliding elements for the evacuation of welding fumes or vehicle's exhaust gases from workshops.

Rail d'extraction en aluminium de section 180x200 mm pour différentes postes d'aspiration de gazs d'escapes ou de fumées de soudure.

Alu-saugschlitzkanal 180x200 mm für bewegliche wagen oder aufroller für Abgas- oder Schweißrauch Absaugung.

Carril de aluminio extrusado, con una sección de 180x200 mm, para sistemas deslizantes de aspiración de gases de escape, o humo de soldadura.

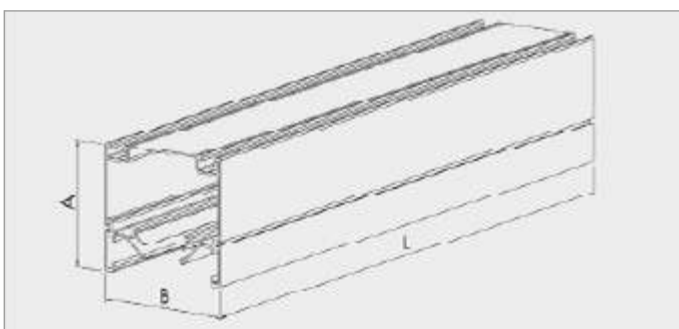
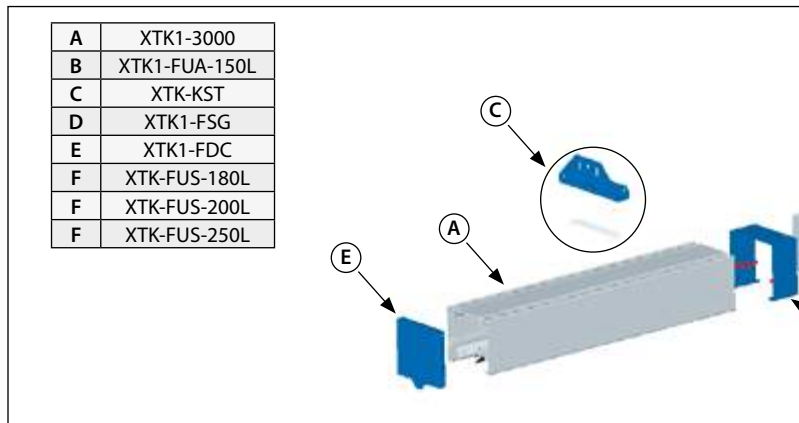

Mod	A (mm)	B (mm)	L (mm)	Kg	Ø eq (mm)	m ³ /h
XTK1-2000	180	200	2000	18,6	170	1800
XTK1-3000	180	200	3000	27,9	170	1800
XTK1-4000	180	200	4000	37,2	170	1800
XTK1-6000	180	200	6000	55,8	170	1800