



**CARBON
ZAPP**



www.es-toolbox.com

2018-19

CZC



**Welcome
to an Innovation
Driven World**

Welcome to an Innovation Driven World

We always strive
for excellence
and innovation



Carbon Zapp is dedicated in manufacturing Automotive Injection Service Solutions, providing a worldwide sales network, investing constantly in R&D and offering efficient support. With today's exponential increase in the automotive industry, Carbon Zapp offers solutions for a healthier, less polluted environment, specializing in designing and manufacturing Diesel and Gasoline Injector Service Benches, that have become a standard for major OE's and general workshops.

As a global supplier to diverse users, with broad knowledge in the automotive industry and through teamwork and skillful personnel, Carbon Zapp is able to support your corporate vision and fulfill your market's needs.

Let's make together the first step towards future and success!

Nikolaos Pantazis
Managing Director
International Business

Dimitrios Pantazis
Managing Director
Manufacturing

03

Company Profile

38

Diesel
Injection Solutions

06

DGS. Discover
Diesel & Gasoline
Specialists Solutions

42

Gasoline
Injection Solutions

08

Diesel
Specialists Solutions

46

Diesel & Gasoline
Injection Solutions

28

Gasoline
Specialists Solutions

54

Innovolutions
for Electric Vehicles
BEV / HEV

36

WDS. Explore
Workshop Diagnostic
& Service Solutions

56

Electric Vehicles





“We have earned our position to the global market because of our commitment to quality products and well known customer service. If we fail to provide satisfaction to our customers, we forfeit our right to their business. Carbon Zapp’s Management and staff loyalty to this business makes it a win-win situation”

**Bill Pantazis,
Founder of Carbon Zapp**



Our Company

Carbon Zapp was founded in 1989 by Bill Pantazis. As a leading manufacturer of Automotive Injection Service Equipment and Tools, Carbon Zapp has its production plant in Athens, Greece and a constantly growing global network in every continent. Recently, the company expanded in Germany by establishing its global headquarters and business administration.

Through a wide range of innovative products, including injector test benches for Diesel and Gasoline injection systems, Engine service equipment and tools, Carbon Zapp offers high quality equipment and customer service to automotive dealers, workshops and educational institutions, as well as for specialized developers, remanufacturers and most major automotive OE's. Carbon Zapp uses over 35% of its profits to update existing products with newer technological advancements and aims to provide simpler methods and tools for a safer environment.

Carbon Zapp today is the **VDO Authorized** global partner for Diesel Specialists to Diagnose and Service CRDi systems, holding the unique technology to correctly control with Energy and accurately test VDO EU5 Common Rail Injectors.

Our Mission

Carbon Zapp aims to provide user friendly, compact and time saving solutions to a wide range of operators, focusing in the automotive injection systems.

Innovation Driven Company

"Innovation" is the key to continuous growth and competitive advantage. Carbon Zapp "Drives" its research team to keep a high ambition level and work on their research, development and technical skills.

On an annual basis, the company invests more than 35% of its profits on research and development for upgrading existing and implementing new products. Carbon Zapp has fostered an extensive group of intellectual property and talented personnel throughout the years. Strategic agreements and world-class component suppliers have contributed in developing advanced technologies and products. in developing advanced technologies and products.

Our Customers

- Diesel Service Centers
- Auto Workshops /Dealerships
- Automotive Aftermarket OEM's
- Parts Remanufacturers
- Automotive OE's
- Developers

Innovation is the key to continuous growth and competitive advantage





Support

At Carbon Zapp, customer satisfaction is a major priority. The staff offers the best service to increase customer trust, earn their loyalty and built their respect. The key to this success is to acknowledge the customers' needs and listen to them.

Global Sales Network

With a logistics center in Athens, Greece, Carbon Zapp can effectively export its products globally in all 5 continents and over 65 countries. The products are trusted internationally for their world class quality. Carbon Zapp takes pride in consistently delivering premium products and reliable customer services.



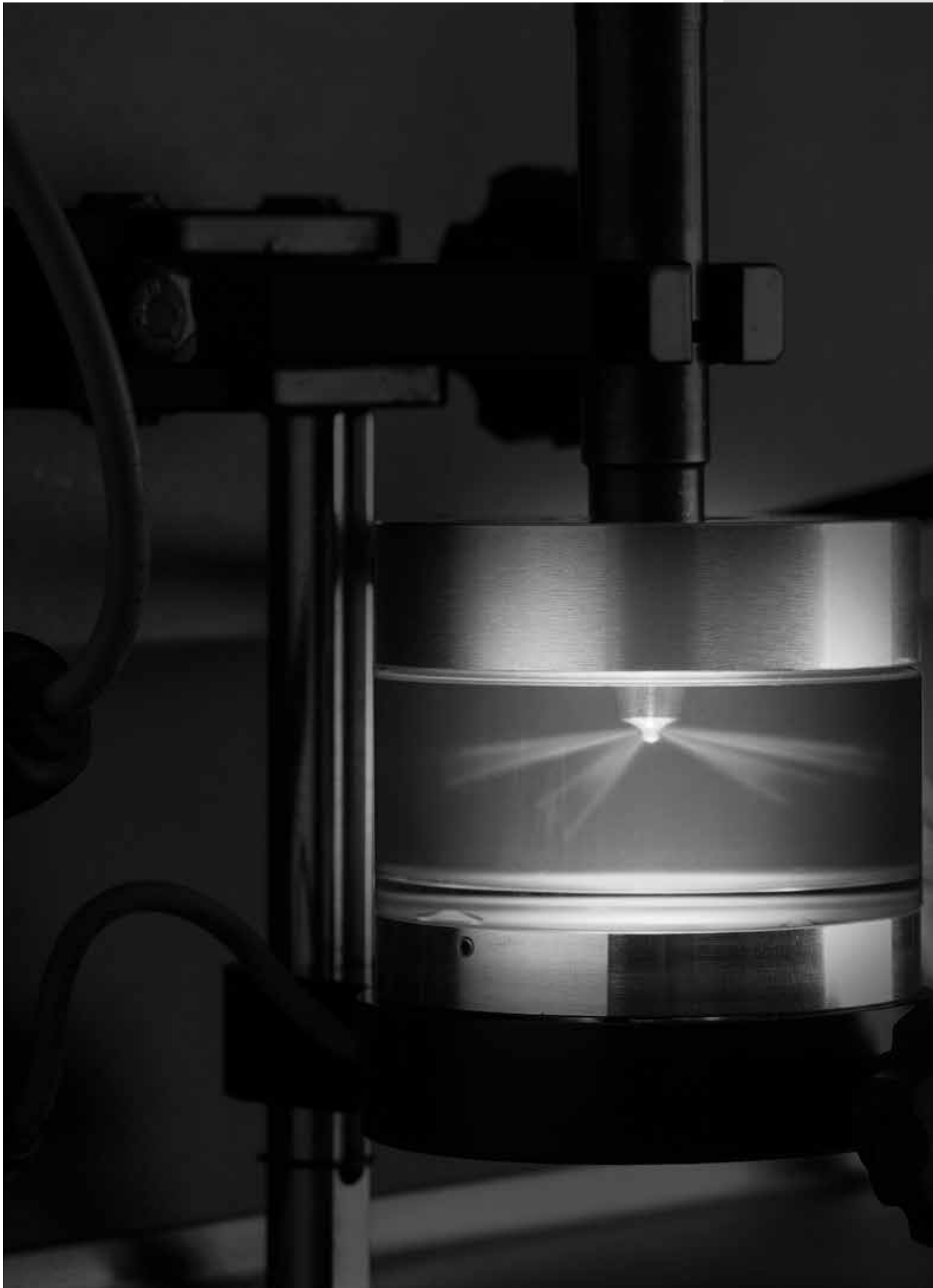

Discover Diesel & Gasoline Specialists Solutions

Innovative, Compact and Professional Solutions for every Diesel Specialist Workshop to Test and Service All Makes and Types of Heavy Duty, Light Duty and Passenger Car Fuel Injection Systems.

CRDi

Common Rail Diesel Injectors



CRp

Common Rail Diesel Pumps

EUi

Electronic Unit Injectors

EUP

Electronic Unit Pumps

HEUi

Hydraulic Electronic Unit Injectors

GDi

Gasoline Direct Injectors

MTBR

The Innovative Standalone Solution for the Diesel Specialist, capable to test every Automotive, Commercial, Industrial and Marine Injection System available in the market today.

Standalone Motor Driven Bench

High Pressures 2800 bar

**NVcT: VCC / NCC / EU6 Needle
Control Testing**

**CRS.3-27 / CRS.2-25 / iArt / And more
EU6 Capable...**

Compact Size for Every Laboratory

All Around 240o work access

Fully Automatic and Fast Testing

Testing & Coding of All Types / Makes



The revolution in Test Benches
In the Service World



MTBR

VDO
Authorized

High Pressure Testing up to 2800Bar (EU6)

Controls NEW Generation CRI3-25 and CRI3-27 injectors with NCC and VCC technology

EU5 and EU6 systems testing [Denso I-Art (6-pin), VDO, etc...]

Injector Coding VDO IIC, Delphi C2i/C3i, Bosch IMA/ISA and Denso QR

VDO CR injectors (EU5) testing only with approved Energy Control by **VDO**

4 CRi/CRiN solenoid or piezo and up to 2 CRiN 4.2 injectors

Nozzle reaction time measurement for all systems via RSP sensor

Actuator Valve measurement via RSP/BIP sensor

All Makes/Types of CR pump. Special Applications CP4/ CAT/ CB18/ CB28/ CP2 etc...

Connects to any Cambox. Automatic function with complete database and test plans (Coding*) with the Hartridge HK-1400A Cambox powered by Carbon Zapp

Compact and robust Unit. 240° Efficient Working Area with Protective Hood fully opening

Controls all Types and Makes of Injectors & Pumps. Includes OEM Database and Test Plans

Connects to Carbon Zapp's HEUI-KIT.M2 solution for testing up to 4 HEUI's

Fully Automatic and fast testing phase through a 15" Touchscreen HMI with AZO software

CRDi Piezo Stack Regeneration function

Blue Limits Diagnosis for Diesel Specialists

Dynamic Electronic Mass (BK) Measurement (CRDi, HEUI, EUI/EUP)

Static Electronic Mass (DFAP) Measurement (CRp)

SPAR: Piezo Stack Filler after repair & re-Assembly (optional)

CGL: EU6 Piezo Stack Air Gap Measurement for SVC evaluation (future update - optional)

Internal cooling system (No water connection needed)

Emergency Stop function (Instantaneous electric brake)



Technical data

Input frequency	50/60 Hz
Number of phases	3 P/PE
Speed range	0 – 6,500 rpm 12.5HP
Powerful Motor with thermal protection	-
Maximum operating ambient temperature	50°C
Base to axis center height	125 mm
High Pressure system Max Pressure	2800 Bar
Supply pump pressure	10 – 800 kPa
Test oil tank	38 L
Waste Oil tank	15 L
Dimensions (W x D x H) Weight	750 x 700 x 1610 mm 465 kg



CRDi

Fully test automatically 4 CRi/CRIN (CRiN 4.2) solenoid & piezo injectors And CR pumps up to 2800bar. For all types and Makes.



CRp

All Makes/Types of CR pump. Special Applications CP4/ CAT/ CB18/ CB28/ CP2 etc

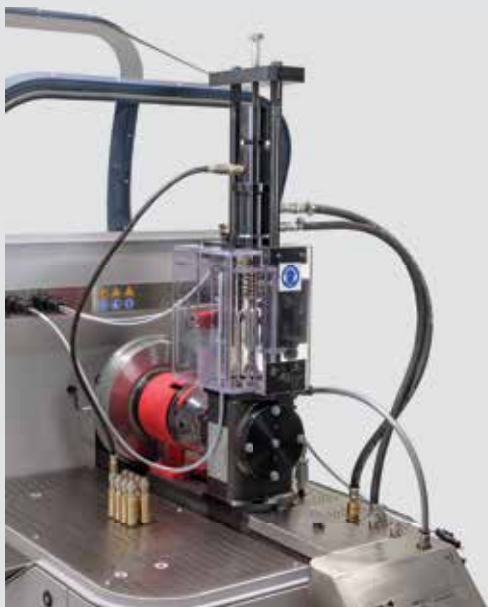

Cambox HK-1400A

Affordable yet full of features, The HK-1400A is highly accurate, robust, flexible and user friendly. The essential choice for any diesel workshop wanting to increase their EUI and EUP capability.



HEUi.Kit.M2

Test up to 4 HEUi injectors with a database and not comparatively. High and Low Pressure oil supply, return and HP oil overflow distribution. A wide variety of adapters is available. Comprehensive HEUi Applications in the market with test plans and database included.



MTBr - CAMBOX

The only Complete Standalone unit to test every Automotive, Commercial, Industrial and Marine Unit Injection System (UIS) available in the market today.



Professional and
Automatic Testing
Solution for all Makes
and Types EUi/EUP



Technical data

Input frequency	50/60 Hz
Number of phases	3 P/PE
Speed range	0 – 3000 rpm 12.5HP
Powerful Motor with thermal protection	-
Maximum operating ambient temperature	50°C
Base to axis center height	125 mm
Supply pump pressure	10 – 800 kPa
Test oil tank	38 L
Waste Oil tank	15 L
Dimensions (W x D x H) Weight	750 x 700 x 1610 mm 350 kg

Compact Standalone Diesel Test Bench

Controls all Types and Makes of Unit Injectors & Pumps. Includes the markets greatest OEM and CZ Database and Test Plans

Automatic function with complete database and test plans (Coding*) with the Hartridge HK-1400A Cambox powered by Carbon Zapp

Cummins ISX / Scania HPI and Cummins QSK Test Plans

Easy and Oil free change of Cam (20sec) by use of the EZO-Kit (optional)

6 injectors testing in less than 1 hour

Compact and Robust Unit. 240° Efficient Working Area

Nozzle reaction time measurement for all systems via RSP sensor (optional)

Actuator Valve measurement via RSP/BIP sensor

Smart Injector / Pump (E3/E1/DAF) Coding coming soon

Fully Automatic and fast testing phase through a 15" Touchscreen HMI with AZO software

Dynamic Electronic Mass (BK) Measurement

Internal cooling system (No water connection needed)

Emergency Stop function (Instantaneous electric brake)

*Note: Future Update

HK-1400A CAMBOX

Universal EUI & EUP Cambox. The New HK-1400A Cambox manufactured by Hartridge and powered by Carbon Zapp fits onto the MTBr and automatically tests completely all Heavy Duty EUi and EUP systems in the market today utilizing the continuously updated database that meets the OE standards.

Test every Automotive, Commercial, Industrial and Marine Unit Injection System (UIS) available in the market today.

Compact, lightweight and easy to operate Unit

Controls all Types and Makes of Unit Injectors & Pumps. Includes the markets greatest OEM and CZ Database and Test Plans with the use of Carbon Zapp's AZO software

Cummins ISX / Scania HPI and Cummins QSK Test Plans,

Easy and Oil free change of Cam (20sec) by use of the EZO-Kit (optional)

6 injectors testing in less than 1 hour

Nozzle reaction time measurement for all systems via RSP sensor (optional)

Actuator Valve measurement via RSP/BIP sensor

Smart Injector / Pump (E3/E1/DAF) Coding coming soon

Blue Limits Diagnosis for Diesel Specialist



The HK-1400A

has been engineered to be accurate and repeatable in testing Unit Injection Systems, yet is affordable for all Diesel workshops worldwide.

We offer a wide-range of easy to fit adapters for every UIS system. Finally, with the use of the EZO-Kit, changing the cam and its position has never been easier and oil mess-free.



Extras and Optionals

EZO-Kit

Use the Easy Oil Supply unit to change the Cam position fast and oil mess-free.



Complete range of UIS Adapters

There is a wide-range of easy to fit adapters for every type and make of EUI and EUP injection systems in the market.



Special Testing Kit

for Cummins ISX / Scania HPI and Cummins QSK Test Plans and Adaptability

TBCr

Carbon Zapp's Revolutionary TBCr Simulator provides the capability for every Conventional Test Bench out in the market to renovate and test All Makes and Types of CRDi – CRp – EUI – EUp – HEUi systems.

Diesel Test Bench
Attachment Unit

High Pressures Control up
to 2800 bar

NVcT: VCC / NCC / EU6
Needle Control Testing

CRS.3-27 / CRS.2-25 / iArt/
And more EU6 Capable...

Compact Size for Every
Laboratory

Fully Automatic
and Fast Testing

Testing & Coding
of All Types / Makes

Diesel Specialists Choice



Test bench Common Rail Kit.
The unique, compact and
Universal solution for every
Conventional Test Bench in the
market to operate with the latest
technology CR injectors.

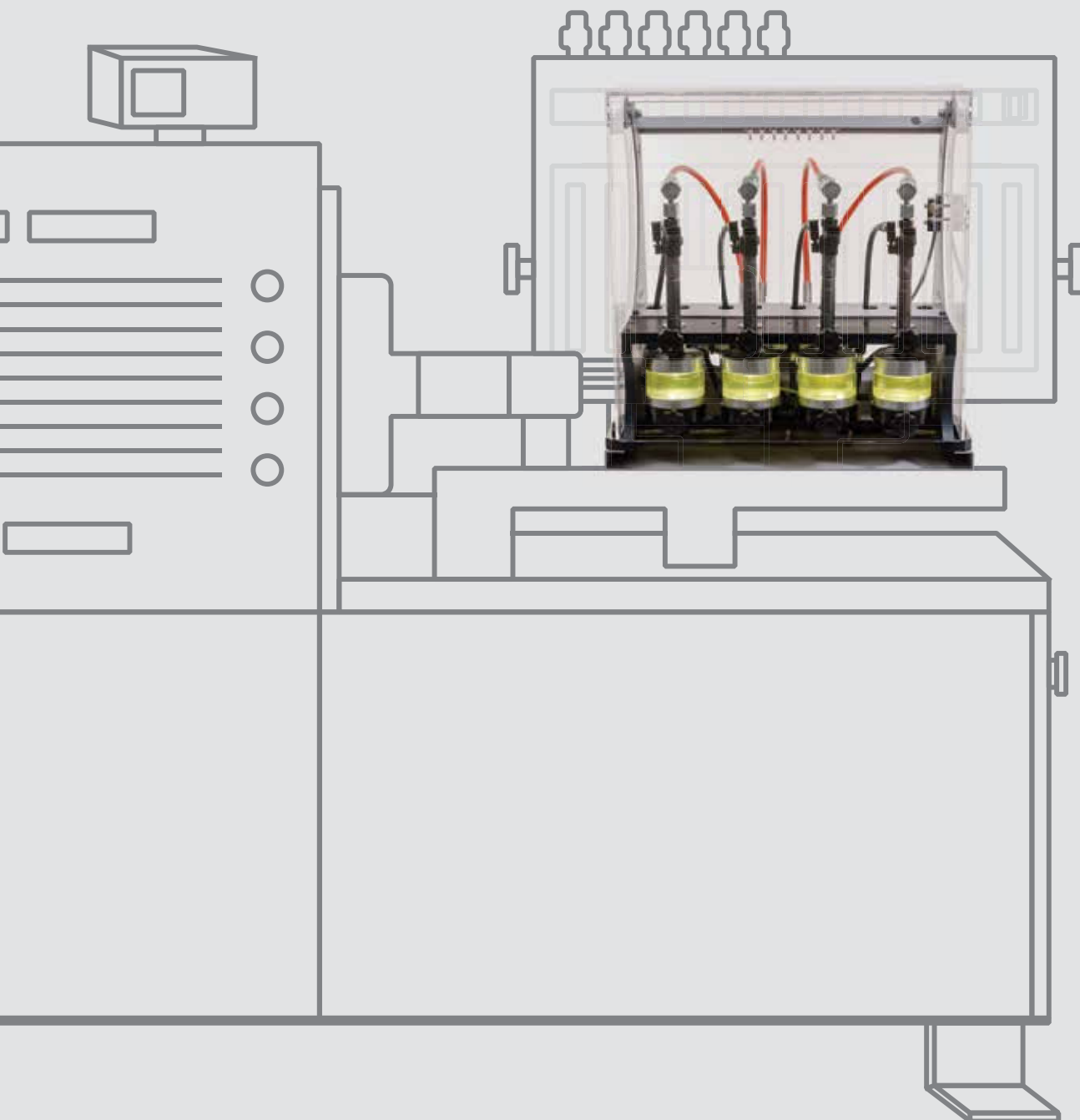

TBCr

Works with every Conventional TestBench in the Market

Controls all Types and Makes of Injectors & Pumps.
Includes OEM Database and Test Plans

Electronic Measurement and Coding for Conventional
Test bench

Connects to any Cambox. Automatic function with
complete database and test plans (Coding*) with the
Hartridge HK-1400A Cambox powered by Carbon Zapp

High Pressure Testing up to 2800Bar (EU6) with BCR-Kit
(optional)

Controls NEW Generation CRi3-25 and CRi3-27
injectors with NCC and VCC technology

EU5 and EU6 systems testing [Denso I-Art (6-pin),
VDO etc...]

Injector Coding VDO IIC, Delphi C2i/C3i, Bosch IMA/ISA
and Denso QR

VDO CR injectors (EU5) testing only with approved
Energy Control by **VDO**

4 CRi/CRiN solenoid or piezo and up to 2 CRiN 4.2
injectors

Nozzle reaction time measurement for all systems via
o-RSP sensor

Actuator Valve measurement via RSP/BIP sensor

All Makes/Types of CR pump. Special Applications CP4/
CAT/ CB18/ CB28/ CP2 etc...

Controls all Types and Makes of Injectors & Pumps.
Includes OEM Database and Test Plans

Connects to Carbon Zapp's HEUI-KIT.M2 solution
for testing up to 4 HEUI's

Fully Automatic and fast testing phase through
a 10" Touchscreen HMI with AZO software

CRDi Piezo Stack Regeneration function

Blue Limits Diagnosis for Diesel Specialists

Dynamic Electronic Mass (BK) Measurement (CRDi,
HEUI, EUI/EUP)

Static Electronic Mass (DFAP) Measurement (CRp)

SPAR: Piezo Stack Filler after repair & re-Assembly
(optional)

Internal cooling system (No water connection needed)

Emergency Safety Stop function

Compact, Lightweight and Portable Unit

The Advanced
Test Bench simulator
that renews every
Conventional Bench
in the market today.
Coding made easy and
affordable for Every
Diesel Specialist.



BCR-KIT

Test bench Common Rail Kit. The unique, compact and Universal solution for every Conventional Test Bench in the market to operate with the latest technology CR injectors, HEUI Injectors, GD*i* injectors and CR pumps.

Easy Clamp-on for 4 CR*i* injectors / 4 CR*i*N / 4 GD*i* / 4 HEU*i* (17-19-21-24mm) or 1 CRp

Conventional Testbench base bolt-on feature

Clear protective hood with safety switch

High Pressure Rail - 2800Bar, HP pressure regulator & sensor

4 x HP flexible hoses 3000Bar with 90-degree swivel & accumulator

1 x HP flexible hose 3000Bar with 90-degree swivel & accumulator for CR pump

4 x Led illuminated adjustable Spray Chambers

Connects to any CRD*i* Simulator.
Recommended for TBCR operation



DCDR / DCDSR

Carbon Zapp's Revolutionary DCD / DCDS Diesel Injector Coder and Simulator provides the capability for every Standalone or Conventional Test Bench out in the market to renovate and test efficiently All Makes and Types of Common-Rail Injectors up to 2800Bar after being serviced by Diesel Specialists.

The Affordable Coding Solution for Everyone

Standalone Diesel Bench Attachment Unit
NVcT: VCC / NCC / EU6 Needle Control Testing
CRS.3-27 / CRS.2-25 / iArt / and more EU6 Capable...
Compact Size for Every Laboratory
Testing & Coding of All Types / Makes

Diesel Specialists Choice



View CZ **DCDR** Tutorial Video



Visit our YouTube channel and watch our new CZ Diesel Test Benches videos

<https://goo.gl/jkoheF>

new



Works with every Standalone & Conventional TestBench in the Market

Controls all Types and Makes of Injectors. Includes OEM Database and Test Plans for 1 CRi/CRiN / CRiN 4.2 / HEUi solenoid or piezo

Electronic Measurement and Coding for every Test bench

Controls NEW Generation CRi3-25 and CRi3-27 injectors with NCC and VCC technology

EU5 and EU6 systems testing [Denso I-Art (6-pin), VDO, etc...]

Injector Coding VDO IIC, Delphi C2i/C3i, Bosch IMA/ISA and Denso QR

VDO CR injectors (EU5) testing only with approved Energy Control by **VDO**

Nozzle reaction time measurement for all systems via RSP sensor

Actuator Valve measurement via RSP/BIP sensor

Fully Automatic and fast testing phase through a 8" Touchscreen HMI with AZO software

CRDi Piezo Stack Regeneration function

Blue Limits Diagnosis for Diesel Specialists

Static Electronic Mass (DFAP) Measurement

Emergency Safety Stop function

Compact, Lightweight and Portable Unit

Connects to any Cambox. Automatic function with complete database and test plans (Coding*) with the Hartridge HK-1400A Cambox powered by Carbon Zapp (optional-future update)

High Pressure Testing up to 2800Bar (EU6) with BCR-Kit (optional)



Z-CODR

Carbon Zapp's Innovative tablet provides the information for every workshop using a Standalone or Conventional Test Bench out in the market to utilize the test plans and database and finally the Coding capability for all Makes and Types of Diesel Systems in the market.

new



The Affordable Coding Solution for Everyone

Includes OEM Database and Test Plans for all Types and Makes of Injectors & Pumps in the market (Testing Capability and precision is only as accountable as the unit tested on)

Provides a comprehensive Coding Solution for every Test bench. (Coding correctness and accuracy is only as accountable as the unit tested on)

Test plans for NEW Generation CRI3-25 and CRI3-27 injectors with NCC and VCC technology

Test plans for EU5 and EU6 systems testing [Denso I-Art (6-pin), VDO, etc...]

Injector Coding VDO IIC, Delphi C2i/C3i, Bosch IMA/ISA and Denso QR

All Makes/Types of CR pump. Special Applications CP4/ CAT/ CB18/ CB28/ CP2 etc...

Blue Limits Diagnosis for Diesel Specialists

new

SPAR

Carbon Zapp Piezo Stack Filler, Air remover and Stack Activator is the only complete automatic solution to assure optimum servicing and operation of Piezo injectors today after being serviced by Diesel Specialists.



Automatic and easy operation for 4 Piezo injectors at once

Connects directly at the return port (backleak)

Only needs single phase 100-250Vac

Lightweight and portable solution

Connects to any Carbon Zapp Test Bench for use of appropriate Test Plans

High Flow Vacuum Power 10KPa and Pressure of 100KPa

Automatic Start / Stop function

Adaptability to all types of Piezo injectors



DSF.4R

Flushing / Cleaning and Servicing bench for 4 Diesel Injectors

Up to 2000Bar HP with 6 bar air supply

Controls all Types and Makes of Injectors.

Fully Automatic and fast cleaning phase

Diesel Specialist usage before testing injectors on OE test bench

8" Touchscreen HMI

CRDi Piezo Stack Regeneration function

CRU.4R / CRU.2R

Common Rail Revolutionary testing solutions for BOSCH, DELPHI, DENSO and VDO, Heavy Duty and Light Duty applications. All types Piezo, Solenoid & Dual-Solenoid actuators.

Standalone Air Driven Bench

High Pressures 2800 bar

NVcT: VCC / NCC / EU6 Needle

**Control Testing CRS.3-27 / CRS.2-25
/ i-Art and more Capable**

Compact Size for Every Laboratory

Fully Automatic and Fast Testing

Testing & Coding of All Types/Makes

Diesel Specialists Choice

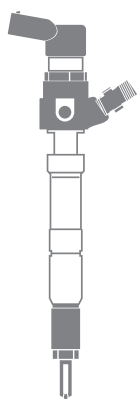

High Pressure Testing up to 2800Bar (EU6) with only 6.5 Bar Air supply input

VDO CR injectors (EU5) testing only with approved Energy Control by **VDO**

Tests New EU6 Generation CRi3-25, CRi3-27, Denso I-Art(6-pin) and more with NCC and VCC technology

Injector Coding VDO IIC, Delphi C2i/C3i, Bosch IMA/ISA and Denso QR

Nozzle reaction time measurement for all systems via RSP sensor

Efficient Working Area with Protective Hood fully opening

The fastest and easiest clamping of injectors in the market

Controls all Types and Makes of Injectors. Includes OEM Database and Test Plans

Fully Automatic and fast testing phase through a 10" Touchscreen HMI with AZO software

CRDi Piezo Stack Regeneration function (wake-up)

Blue Limits Diagnosis for Diesel Specialists

Dynamic Electronic Mass (BK) Measurement

Connects to Carbon Zapp's HUIR solution for testing HEUI Systems

Dual System - Flushing / Cleaning system using detergents and Ultrasonics

Emergency Safety Stop function



CRU.4R

Compact Diesel Common Rail Test Bench for 4 CRi(N) / 2 CRiN 4.2 solenoid or piezo injectors in under 25min.



CRU.2R

Compact Diesel Common Rail Test Bench for 1 CRi(N) / 1 CRiN 4.2 solenoid or piezo injector in under 7min

HUIR - A

A fast and easy to operate solution to fully diagnose Hydraulic Unit Injection Systems is now available for Diesel Specialists as an attachment unit to their CRU.2r/ CRU.4r Common Rail machine.

Controls all Types and Makes of HEUI Injectors.

Test & Service Attachment bench for 1 HEUI Diesel Injector up to 300Bar, Solenoid & Dual-Solenoid

Semi-Automatic Operation Under 8min testing phase

Nozzle reaction time measurement for all systems via RSP sensor (optional)

Blue Limits Diagnosis for Diesel Specialist

Includes Database and Test Plans for most HEUI injectors in the market today

Electronic Measurement via the CRU.2r/ CRU.4r Test Bench

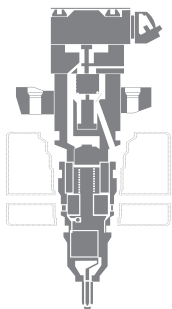

HEUI Applications

- Caterpillar 3126, 7.3L,
- Caterpillar C7/C9,
- Ford Powerstroke 6.0L,
- 7.6L, 9.3L Navistar
- Isuzu Trooper and more...





Repair Tools

Assembly/Disassembly
and Repair Tools for:
Diesel Common Rail
Injectors Diesel
Common Rail Pumps

GDU.4R / GDU.2R

The only professional solutions for OE's, Remanufacturers and workshops to test & service Gasoline Direct Injection Systems. Gasoline Direct Injection (GDi) requires high pressure testing to truly diagnose injector operation faults.

systems

Bosch, VDO, Delphi, Hitachi, Denso and others

GDI / FSI / HPI / CGI / JTS / IDE / SCI / HPDI / DISI / SIDI etc.

Piezo and Solenoid

injectors

Up to 850Bar+



Carbon Zapp's Innovative Standalone Test benches provide still the only complete testing solution in the market today, with a unique database. The Experience, Seniority and Working closely with the OEM's the last 15 years has given us the advantage to develop test plans and diagnose problems according to the OEM expectations. High Pressure Testing up to 850Bar (EU6 / EU7 prospect) with only 5 Bar Air supply input

Controls all Types and Makes of Injectors. Includes OEM Database and Test Plans

Low Pressure Testing for Conventional MPFI or Racing application Injectors 0-10Bar

Controls NEW Generation High Pressure GDi with multiple Step Current profiles

LPG for Heavy Duty Applications (Trucks, Commercial Vehicles)

VDO / Siemens GDi injectors (EU5) testing only with approved Energy Control by **VDO**

Nozzle reaction time measurement for all systems via RSP sensor

Dual System - Flushing / Cleaning system using detergents and Ultrasonics

Efficient Working Area with Protective Hood fully opening

The fastest and easiest clamping of injectors in the market

Fully Automatic and fast testing phase through a 10" Touchscreen HMI with AZO software

GDi Piezo Stack Regeneration function. The only way to correct GDi Piezo injectors after Cleaning them internally and reverse flushing them

Reverse flushing adapter and function with 25Bar pressure

Blue Limits Diagnosis for Specialists

Dynamic Electronic Mass (BK) Measurement

Prepared for Future Injector Coding

Emergency Safety Stop function

GDU.4R



Compact Gasoline DIRECT Injector GDi Test Bench for servicing 4 solenoid or piezo injectors in under 15min.

GDU.2R



Compact Gasoline DIRECT Injector GDi Test Bench for servicing 1 solenoid or piezo injectors in under 5min.

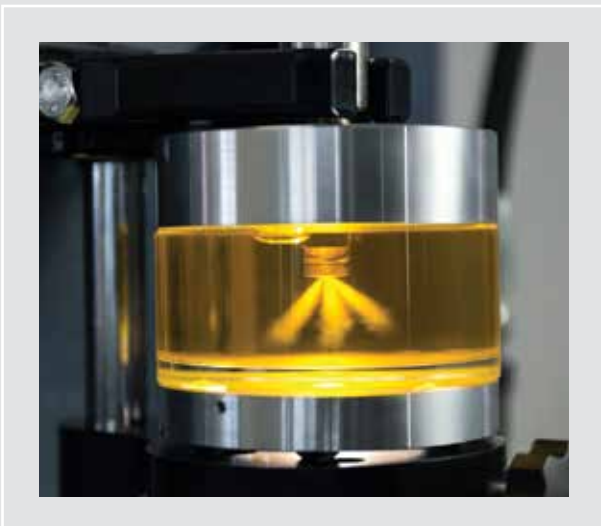

CZ Technologies

Tests Performed

R2LC

Electrical actuator test for k Ω / μ F, Ω / μ H

CFL

Check For internal and external Leaks

NLT

High Pressure Nozzle Leakage

LKT

Static Back Leakage (Overflow) measurement

aNOP

Automatic Nozzle Opening Pressure

iVM (FL, PL, EM, LL, PI)

Injector Volume Measurements (full-load, part-load, emissions, low-load, pre/post-injection.)

iVM-aDFi

Injector Volume Measurement Performance Ramp (multiple testpoints slope / different Pressure points)

RSP

Injector Nozzle Response Time

BIP [EUI / EUP systems]

Injector / Pump Control Valve Response Time for Unit Injection Systems

SPR

Dynamic Spray Test performed in all testing conditions up to 2800Bar

Extra Tests

High pressure Control Valve operation (DRV, IMV, VCV, PCV, etc...) High Pressure Sensor reaction, High Pressure relief safety valve operation CR Pump flow limiter valve operation (ZME, IMV, SCV.)

MIM

Multiple Injection Metering (up to 8 fully programmable delay and overlap times)

Features

AZO Software

Advanced Android based HMI/PC, Wi-Fi printing, sharing, syncing, software/ hardware & database updating, via USB or Wi-Fi, Real-time Oscilloscope and CSV data export

Reports

Easy fail-track color report for each component tested. Single-page Quick report or Multi-page Analytic reporting

aMACC Flushing / Cleaning function

Automatic chemical treatment and flushing of the injector before testing under high pressure and using a specially formulated detergent

RSP / BIP

Response Sensor (RSP) adaptable to all Injector Nozzles

Response Sensor (BIP) adaptable to all Control Valves [EUI/EUP].

Precise measurement of Control Valve & Nozzle reaction time to easily diagnose a slow acting injector, a retarded injection event, poor engine performance and emissions issues."

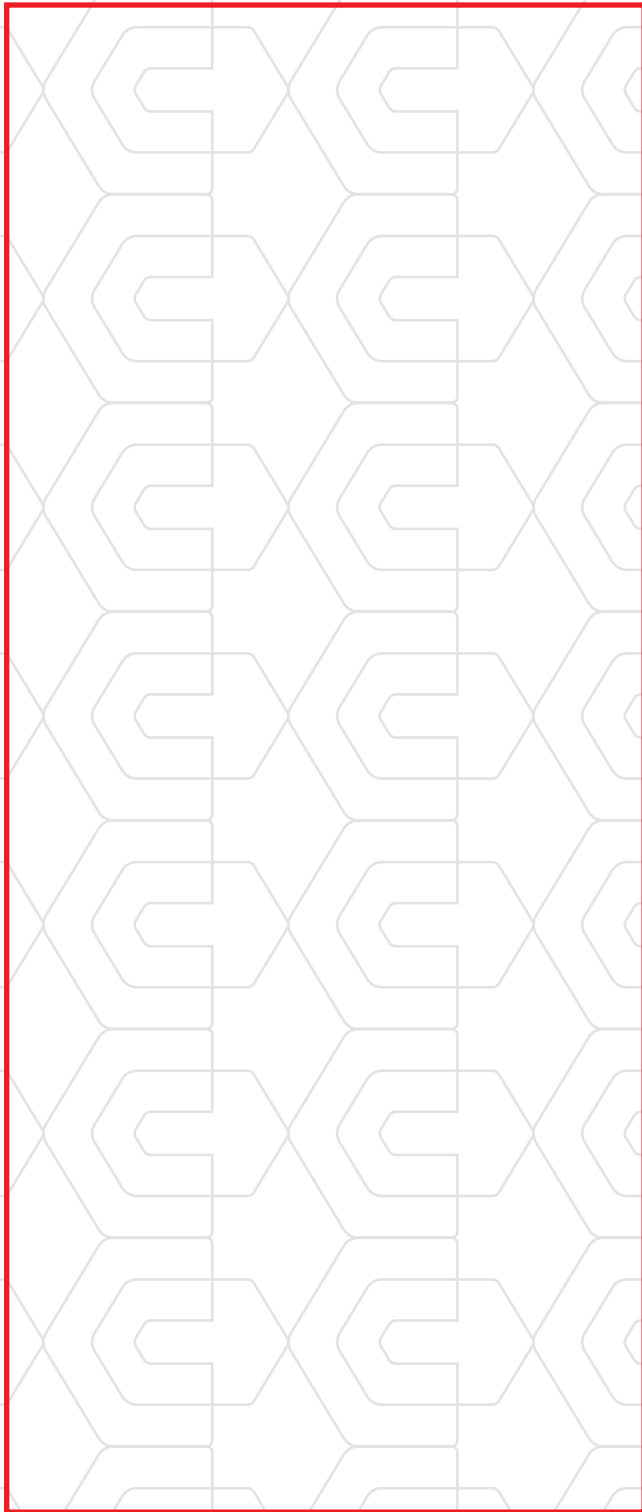

1. BK



2. DFAP

Electronic Measurement

1. Dynamic Electronic Mass Measuring Sensor (BK). Ramp function capable for aDFI function, Injector Coding Capable, Acc:0.2%FS, repeatability: 0.05%. Fast and Accurate Measurement with Coriolis technology
2. Static Electronic Mass Measuring Sensor (DFAP) Acc: 0.6%FS, Accurate and Repeatable Measurement with Differential Absolute Pressure Technology

Extras/optionals

Adapters Kit

CRDi Solutions

A complete range of CRIN adapters kits for Heavy Duty applications are available. Commercial, Industrial, Marine applications and continuously being updated and released.



Adapters GDi Kit

Complementary set of GDi adapters, fittings and connectors for the most commonly tested injectors in the market today. A wide variety of additional GDi adapters is available for all Makes & Types.



Adapters kit

A Wide range of CRDi overflow connection fittings, pressure Regulators, electrical connectors and more required to adapt to All makes and Types of Injectors is provided. For MTBr units the Standard Adapters for Bosch CP1/CP3 and most common Applications of VDO, Denso and Delphi are included.



GDi LP-Kit

Low Pressure Gasoline kit is now available



HEUI Systems

A complete range of HEUI adapter kits, wiring harnesses and more are available for: CAT C7/C9, CAT 3126 / Navistar, CAT 3406, Ford Powerstroke, Isuzu Trooper and more.



Heavy Duty Solutions EUI/EUP Systems

A complete range of EUI/EUP adapter kits, cams, rods, wiring harnesses and more are available. New systems are being continuously released for Smart injector/pumps and more.



HEUI.Kit.M2

A Kit to connect up to 4 HEUi injectors. Distribution of low Pressure oil supply & return pump and a wide variety of adapters is available. Comprehensive HEUI Applications in the market with test plans and database included for CAT C7/C9, CAT 3126 / Navistar, CAT 3406, Ford Powerstroke, Isuzu Trooper and continuously being updated.



Extras/optionals

Adapters Kit

CRp CP3.3/3.4 Kit

A complete kit including Clamping bracket, flange, coupling and fittings to fully test and control the Heavy Duty Application Bosch CP3.3 and CP3.4 Common rail pump. (Requires CPL-Kit)



CRp-CB18/CB28 Kit

A complete kit including Clamping bracket, flange, coupling and fittings to fully test and control the Asian Applications Bosch CB18 and CB28 Common rail pumps. (Requires CPL-Kit)



CRp -CAT

A complete kit including Clamping bracket, flange, coupling and fittings to fully test and control the CAT Common rail pump. (Requires CPL-Kit)



CPL-Kit

Adjustable low pressure engine oil supply kit for lubrication of Heavy Duty CR pumps. Portable 12VDC operation. Adapts to any test bench in the market.



CRp-CP4 Kit

A complete kit including Clamping bracket, flange, coupling and fittings to fully test and control Bosch CP4.1 and CP4.2 Common rail pumps. (Requires CPL-Kit)



CRp-IP.3 Kit

A testing kit to adapt to All Makes CR Pumps and measure the internal Low Pressure supply pump as well as the vacuum made from the CR pumps. Includes couplings and fittings for Bosch, Delphi and generic application pumps.



CRp-Standard Adapters Kit

A complete kit including Clamping bracket, flange, coupling and fittings to fully test and control the most commonly used Heavy Duty Application Bosch CP1 and CP3.

CRp -VDD (VDO-DENSO-DELPHI)

An extensive range of every Clamping bracket for all Types and Makes CR pumps for passenger cars, light duty and heavy duty applications is available.



Ultrasonic Devices

Ultrasonic Baths are available at sizes up to 120L featuring:

- 42KHz frequency
- Sweep technology*
- Degas function*,
- Controlled Heater and more...



Oils & Fluids

1. Diesel Injector Calibration Oil (ISO4113)
2. Gasoline Injector Calibration Oil (Exxsol 40/60 equivalent)
3. Ultrasonic Solvent (Concentrated) 4L|20L|208L
4. Diesel / Gasoline Injector Cleaning Detergent 2L|25L"

Portable stand

Compact, lightweight, robust with accessories cabinet







Explore Workshop Diagnostic & Service Solutions

Innovative, Compact and Affordable Solutions
for every Workshop to Test and Service
All Types of Diesel & Gasoline Fuel Injection
Systems. CRDi - EUi - EUP - GDi

Diesel Common Rail

Diesel Heavy Duty

Gasoline Direct Injection GDi

Gasoline Fuel Injection

Engine & Exhaust Servicing

Fuel Injection Tools & Extractors

Diagnostic Fuel Injection Tools



DS1R / DS2R

Common Rail Revolutionary testing solutions for BOSCH, DELPHI, DENSO and VDO. All types Piezo, Solenoid & Dual-Solenoid actuators. Affordable Solutions for every workshop to easily test and quickly diagnose major failures on all Types and Makes of Diesel CRDi's in the Market today.

Standalone Air Driven Bench

High Pressures 2200 bar

**NVcT: VCC / NCC / EU6 Needle
Control Testing**

**CRS.3-27 / CRS.2-25 / iArt / and more
EU6 Capable...**

Compact Size for Every Laboratory

Fully Automatic and Fast Testing

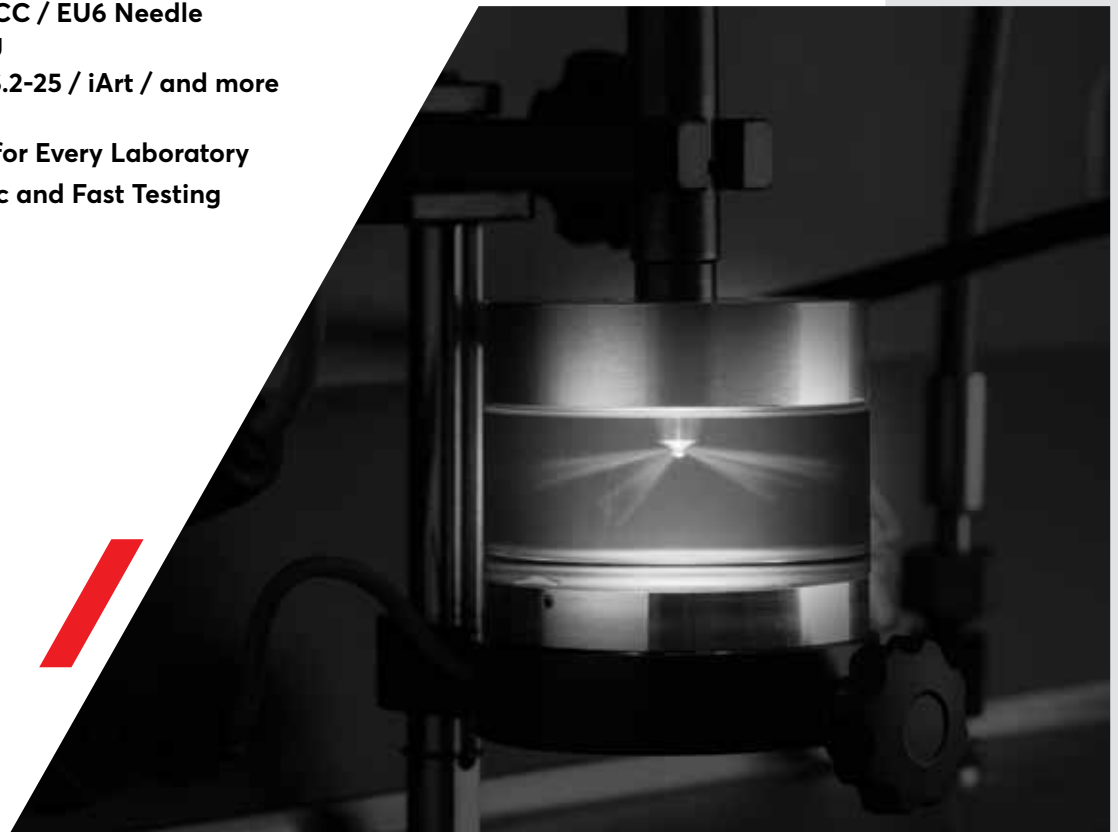

Diesel Common Rail

High Pressure Testing up to 2200Bar (EU6) with only 6.5 Bar Air supply input

Controls NEW Generation CRI3-25 and CRI3-27 injectors with NCC and VCC technology

EU5 and EU6 systems testing [Denso I-Art (6-pin), VDO, etc...]

VDO CR injectors (EU5) testing only with approved Energy Control by **VDO**

Injector Coding with the use of Z-CODr (optional)

Manual Operation. Dual System Flushing/Cleaning capability

Nozzle reaction time measurement for all systems via RSP sensor

Efficient Working Area with Protective Hood fully opening

The fastest and easiest clamping of injectors in the market

Controls all Types and Makes of Injectors. Includes OEM Database and Test Plans

Fast testing phase through a 8" Touchscreen HMI with AZO software

CRDi Piezo Stack Regeneration function

Blue Limits Diagnosis for Specialists Service

Static Electronic Mass Measuring Sensor (DFAP) Acc: 0.6%FS, Accurate and Repeatable Measurement with Differential Absolute Pressure Technology (DS1R)

Accurate illuminated Volumetric Tubes Measurement with auto-drain function. resolution 0.5ml, accuracy $\pm 1\text{ml}/65\text{ml}$ (DS2R)



Compact Diesel Common Rail Test Bench for 1 CRi(N) / 1 CRiN 4.2 solenoid or piezo testing in under 10 min. Electronic Measurement with DFAP Technology 12 min.



Compact Diesel Common Rail Test Bench for 1 CRi(N) /1 CRiN 4.2 solenoid or piezo Volumetric Tubes Measurement in 15-20 min



Diesel Heavy Duty

UIPr-S

Standalone air driven unit capable to easily diagnose major faults on all Makes & Types of Unit Injection Systems (EUI / EUP).

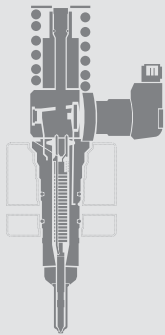

Fully Automatic and fast testing phase through an 8" Touchscreen HMI with AZO software

Standalone Test Bench for 1 EUI/EUP Diesel Injector. 10min testing phase

Blue Limits Diagnosis for Specialists Service

Cummins ISX / Scania HPI and Cummins QSK Test Plans

Nozzle reaction time measurement for all systems via RSP sensor (optional)

Actuator Valve measurement via RSP/BIP sensor (optional)

Electronic Static Mass Measurement (DFAP)

Piezo, Solenoid & Dual-Solenoid actuators





**Heavy Duty, Industrial,
Marine and Passenger
Car UIS Applications**

Delphi E3/E1, Delphi, DAF SmartPump /Injector), Scania HPI/Cummins ISX, Cummins QSK, Volvo (Bosch & Delphi), John Deere, Scania/Yanmar, Iveco, VW PDE, All CAT's, Cummins Celect, Detroit Diesel, Cummins, MB Actros, MB Atego, Mack, DAF, and more...

**Heavy Duty Solutions
EUI/EUP Systems**

A complete range of EUI/EUP adapter kits, cams, rods, wiring harnesses and more are available. New systems are being continuously released for Smart injector/pumps and more.

Service Tools

Assembly / Disassembly
and repair tools
for Diesel Common Rail
Injectors Extractors
for Diesel Injectors
(CRDi-EUI-EUP-HEUi)

Gasoline Direct Injection GDi

GD1R

The Affordable GDi Service Bench is available for every Workshop to test and thoroughly Diagnose all Faults on Gasoline Direct Injectors. GDi Systems require high pressure testing to truly diagnose operation faults.

**High Pressure Testing up
to 450Bar (EU6 / EU7 prospect)
with only 5 Bar Air supply input**



Gasoline Direct Injection GDi

Compact Gasoline DIRECT Injector GDi Test Bench for 1 solenoid or piezo injector in under 7min.

High Pressure Testing up to 450Bar (EU6 / EU7 prospect) with only 5 Bar Air supply input

Automatic/ Manual and fast testing phase through an 8" Touchscreen HMI with AZO software

Low Pressure testing for 1 conventional MPFi or Racing application injectors 0-10Bar

Controls all Types and Makes of Injectors. Includes OEM Database and Test Plans

Controls NEW Generation High Pressure GDi with multiple Step Current profiles

LPG for Heavy Duty Applications (Trucks, Commercial Vehicles)

VDO / Siemens GDi injectors (EU5) testing only with approved Energy Control by **VDO**

Nozzle reaction time measurement for all systems via RSP sensor

Efficient Working Area with Protective Hood fully opening

GDi Piezo Stack Regeneration function. The only way to correct GDi Piezo injectors after Cleaning them internally and reverse flushing them

Reverse flushing adapter and function with 25Bar pressure

Blue Limits Diagnosis for Specialists Service

Electronic Static Mass Measurement (DFAP)

Ultrasonic cleaning function

The fastest and easiest clamping of injectors in the market



Gasoline Fuel Injection

GS8 / GS4

The efficient, cost-effective and proven workshop solution to bench test and service every gasoline fuel injector.



Bench for Testing & Ultrasonic Cleaning up to 8 Fuel Injectors

Bench for Testing & Ultrasonic Cleaning up to 4 Fuel Injectors



- Manual Function
- Electronic Pressure Control 0-10Bar
- Dynamic & Static iVM
- Manual-iRF function
- Injector Leak Test function

DISPLAY SCREEN



- Fully Automatic Function
- Electronic Pressure Control 0-10Bar
- "Racing Injectors Capable"
- Dynamic & Static iVM
- Auto-iRF function"
- "Injector Leak Test function
- User-Friendly Design
- Language Localization"



iRF



ULTRASONIC BATH

Gasoline Fuel Injection**Features****iVM: Injection Volume Metering**

Precise graduated led illuminated tubes are used for efficient diagnosis of uneven flow rates and weak or defective nozzle springs. Automatic drainage after each test resolution 1ml, accuracy $\pm 1\text{ml}/130\text{ml}$

ECMR (Optional Unit)

Gasoline Injection System Electronic Control Module for Activating and Controlling all Types and Makes of actuators (solenoid and piezo) utilizing an 8" touchscreen HMI with AZO software and database. Compact Actuator and Control Module for 4 GDi Piezo Injectors and NEW Generation High Pressure GDi with multiple Step Current profiles

iSPC

Illuminated Spray Pattern Chamber used for visual diagnosis of correct injection

Ultrasonic Cleaning

Baths Available at sizes up to 120L* featuring: 42KHz frequency Sweep technology* Degas function*, Controlled Heater and more...

iRF

Injector Reverse Flush Device used to remove all dirt remained inside injector body after cleaning with the use of Ultrasonics

eRSO

Electrical Resistance, Short Circuit & Open Circuit Test

0-10 Bar

Testing Capability of All Types of Injectors up to 10Bars Maximum. GD Units are available for High Pressure Direct Injectors up to 850Bars

Service & Repair

Increased exhaust emissions
 Reduced engine performance (Power, Torque)
 Increased fuel consumption
 Poor drive-ability situations
 Direct injection systems failure (Leaks, Pressure drop)
 Rough idle and periodic stall of the engine
 Conditions that lead to long-term catalytic converter damage
 Extended engine start-up MIL
 - check engine light-up

**Systems Tested**

Solenoid Direct Injectors (G-Di, FSI...)
 Multi-Port Fuel Injectors (MPFi / SPFi)
 Racing Application Injectors*
 Central-Port Fuel Injectors (CSFi / CPFi)
 Throttle Body Injectors (TBI / CFi)
 Continuous Injection Injectors (K-Jetronic),
 Marines Application Injectors (E-TEC / FICHT)
 Motorcycle Application Injectors (Racing*)
 LPG & Alternative fuels Injectors

Gasoline Fuel Injection

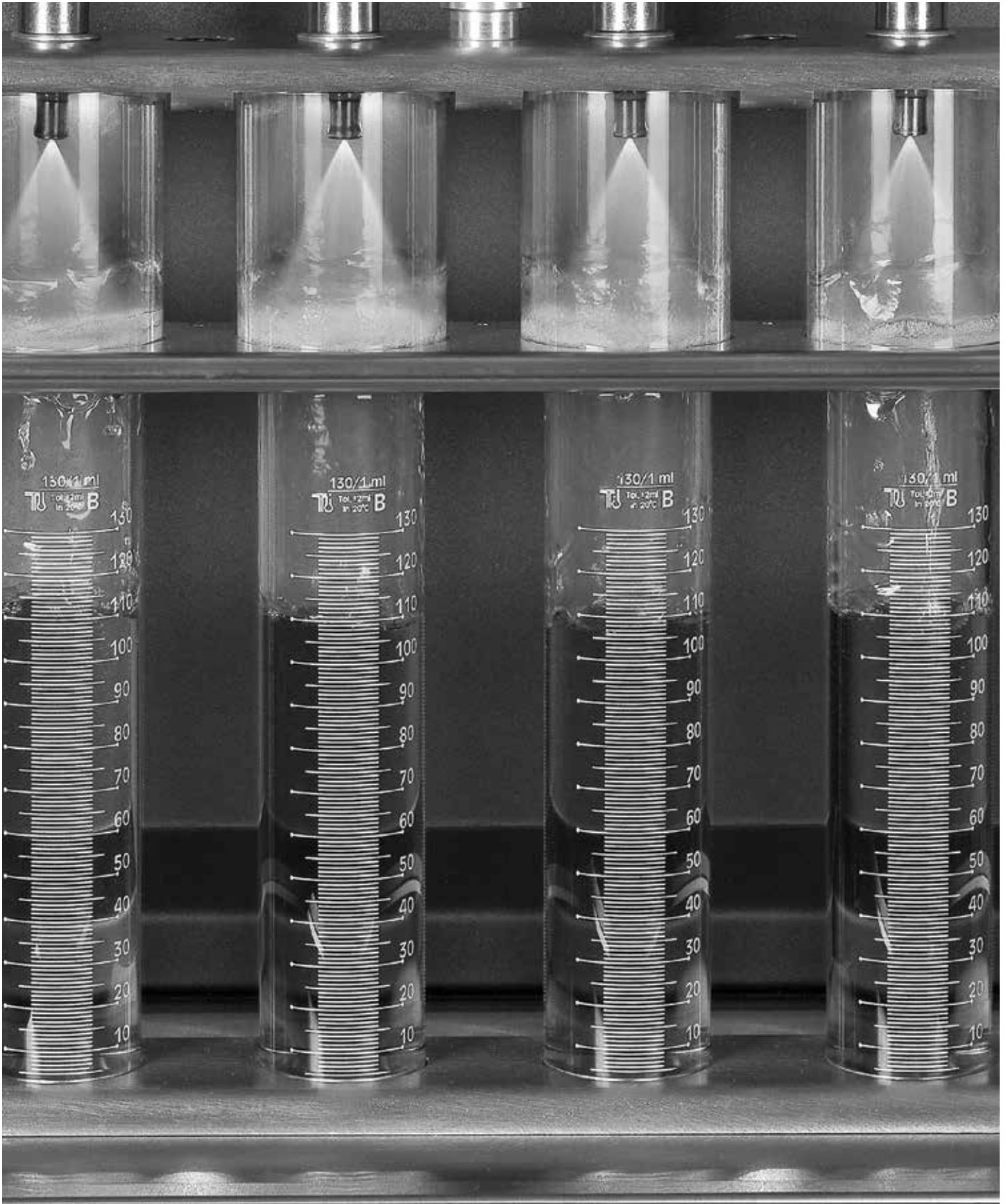

Diesel Common Rail
Gasoline Direct Injection GDi

ECMR

Diesel & Gasoline Injection System Electronic Control Module for Activating and Controlling all Types and Makes of actuators (solenoid and piezo) utilizing an 8" touchscreen HMI with AZO software and database.

new

Compact Actuator and Control Module for 4 GDi -
4 CRi(N) - 2 CRiN 4.2 - (1 CRp - 1EUI - 1 EUP)* - 1 HEUI

Controls all Types and Makes of Injectors. Includes
OEM Database and Test Plans

Controls NEW Generation CRi3-25 and CRi3-27
injectors with NCC and VCC technology

EU5 and EU6 systems testing [Denso I-Art (6-pin),
VDO, etc...]

Controls NEW Generation High Pressure GDi with
multiple Step Current profiles

VDO CR injectors (EU5) testing only with approved
Energy Control by **VDO**

Injector Coding with the use of Z-CODr (optional)

CRDi Piezo Stack Regeneration function

Blue Limits Diagnosis for Specialists Service



**Future Optional Update*

Extras/optionals

Adapters Kit

CRDi Solutions

A complete range of CRIN adapters kits for Heavy Duty applications are available. Commercial, Industrial, Marine applications and continuously being updated and released.



Direct Injection Solutions

A complete range of adapters* for All Makes and Types GD-I and Top-Feed Conventional Injectors are available



Tools

SRC-505

Gasoline injector screen filter extractor tool



GV3-4100

Injector puller kit suitable for gasoline direct injection engines (VAG-FSI and others)



Fuel Injection Solutions MARINE

E-TEC Kit *

Complete Rail Kit specially designed for adaptation to E-TEC / FICHT Injectors



Gasoline Fuel Injection

Fuel Injection Solutions

Standard Kit [GSx-10 units]

Fuel Rail & Adapters for all Makes and Types of Top-Feed and G-DI Injectors

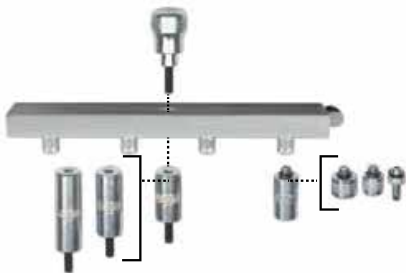

TBI Kit * [GSx-10 units]

Fuel Rail & Adapters for all Makes and Types of Throttle Body and Side-Feed Injectors



Exclusive Kit [GSx-20/30 units]

Complete set of Fuel Rail & Adapters, designed for Easy and Fast adaptation to all Makes and Types of Top-Feed, G-Di and Side-Feed Injectors

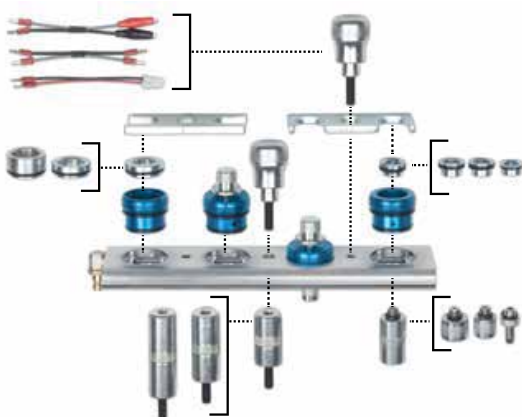

Ultrasonic Devices

Ultrasonic Baths are available at sizes up to 120L featuring:

- 42KHz frequency
- Sweep technology*
- Degas function*,
- Controlled Heater and more...



Oils & Fluids

1. Diesel Injector Calibration Oil (ISO4113)
2. Gasoline Injector Calibration Oil (Exxsol 40/60 equivalent)
3. Ultrasonic Solvent (Concentrated) 4L|20L|208L
4. Diesel / Gasoline Injector Cleaning Detergent 2L|25L"

Portable stand

Compact, lightweight, robust with accessories cabinet



ES3

Diesel & Gasoline Engine, DPF & Intake Manifold Treatment Unit

Benefits

- Exhaust emissions reduction more than 70%
- De-Carbonization of the combustion chamber
- De-carbonization of the catalytic converter
- De-Carbonizing of Intake Manifold and throttle body
- DPF Cleaning without disassembling
- Maximum restoration of engine's performance
- Reduction of fuel consumption"

Systems

- Common-Rail and Conventional Diesels
- Gasoline Direct Injection (G-Di, FSI, HPI, CGI etc.)
- Conventional Fuel Injection (MPFI / TBI / CIS)
- LPG and Alternative fuels
- Carburated Engines

- Common-Rail system cleaning
- High Pressure pump conditioning
- Optimum fuel combustion gain
- Blocked valves and piston rings release
- Improved idle-speed stability
- Fading of engine knocking
- Prevention of long term expensive repairs
- User-Friendly, On-Display guide with language localization
- Automatic Pressure adjustment and Operation Cycle
- Use of External Tank
- Dual-Tank system
- Adaptability to all makes and models
- Portable, Lightweight and Robust unit



DI.2

DPF & Intake Manifold Treatment Unit

Benefits

De-Carbonizing of Intake Manifold
and throttle body

DPF Cleaning without disassembling

User-Friendly, On-Display guide with
language localization

Automatic Pressure adjustment
and Operation Cycle

Use of External Tank

Adaptability to all makes and models

Portable, Lightweight and Robust unit



Detergents

The environmental friendly ES Series Detergents for Decarbonizing the engine activates the inert carbon molecules, resins, dust varnish and gums that accumulate inside the engine components, and burns them with the combustion process.



Adapters

Exclusive fuel system adapters kit available
for all types of engine configurations*



DPF.01

Diesel Particulate Filter Cleaning Adapter Kit. Use of Non-Combustible environmental friendly detergent to efficiently clean Particulate Matter, Carbon Soot, Ash, Organic materials and Sulfates.

Application programmable duty-cycle software integrated



IMC.01

Intake Manifold Cleaning Adapter Kit and Non-Combustible environmental friendly detergent. Application programmable duty-cycle software integrated





FST / FST-HF

Diesel & Gasoline
Fuel System Tester

DIAGNOSIS

- Incorrect fuel pressure
- Incorrect system fuel flow Plugged fuel filter
- Faulty fuel pump
- Plugged fuel pump inlet strainer Faulty fuel pump check valve
- Leaky fuel injectors
- Incorrect operation of the fuel pressure regulator Fuel foaming and/or contamination
- Restrictions in supply/ return fuel lines
- Intake manifold vacuum fluctuation
- Exhaust back-pressure for testing DPF & Catalytic Converter
- Turbo-boost pressure operation
- Adaptability for all Makes, Models and Types

FEATURES

- Compact, Portable and Robust tool for use in the workshop
- High flow capability for Racing and Performance applications[FST-HF]
- Easy readable analog gauges: Fuel Pressure, Manifold Vacuum, Exhaust Back-Pressure
- Durable and clear analog flow tube Spill-free quick connectors
- Easy hook for mounting on engine hood



HP-G2500

Common-Rail Gauge

FEATURES

- New Common Rail Injection Systems
- Up to 2500Bar
- Compact & Portable
- Dynamic & Static tests
- Adaptable to all CRDi Systems



HP-G250

High Pressure Gauge

FEATURES

- Conventional Diesel Systems
- G-Di Gasoline Fuel Systems
- Up to 250Bar
- Compact & Portable Dynamic & Static tests
- Adaptable to all DI & G-Di Systems*



CRPT-110

Digital Common Rail
Pressure Tester

DIAGNOSIS

CRDi system operating
pressure CRDi system
leaking

FEATURES

- Easy Operation / Robust design
- Adaptability to All Makes sensors
- Operation Range 0-2000 Bar
- Measurement resolution of 1 bar
- Indication for defective pressure sensor
- Fault detection indicated by a red warning LED
- Automatic shut-off after 1 minute
- Power supply by 9 V battery (standalone unit)



CRMK-110

Common Rail Injectors
Backflow Kit for All
Injector Makes

DIAGNOSIS

CRDi Excessive
Back-Leak

FEATURES

- Test kit for checking the return flow volumes from Common-Rail Injectors
- Plexiglass robust container with graduated scales for easy comparison
- Metal chain hook to hold tester in upright position of the engine hood
- Set of backleak connectors for BOSCH, VDO, DELPHI and DENSO injectors

PIMK-010

Piezo CRDi Backflow
Pressure Tester

DIAGNOSIS

Piezo CRDi return
pressure Piezo injector
proper operation

FEATURES

- Transparent Plexiglass tester to permit view of any air pockets which may be present in the fuel
- Interchangeable vacuum gauge on the test unit for further testing capabilities
- Adaptability for most injectors in the market
- Pressure relief valve for safe removing from engine
- Adaptable to BOSCH (15 Bar gauge) and VDO, DELPHI & DENSO (+3 Bar gauge)





Innovations for Electric Vehicles BEV / HEV

Carbon Zapp evolves in e-mobility.
Innovative Service and Consumer Solutions
for BEV and HEV vehicles are made Easy and
Safe to use.

BRSEV

eBoostEV



BRSEV

The BRSEV, is able to thoroughly test the complete HV circuit of a EV / HEV battery for safety and diagnostic purposes, charge and discharge single cell modules and finally check their air tightness.

1 High Voltage Potential & Diagnosis

Functions

All-Pole Voltage Test (lack of voltage)

Insulation Resistance Test (Insulation-R as a function of V and A)

SAE J1766 Insulation Resistance Test (under load with parallel resistance)

Full measurement (Voltage, HV insulation R and SAE J1766 tests done semi-automatically)

Equipotential bonding check

Resistance measurement (Ohm)

Diode test

Capacity measurement

Insulation monitor check



Safety-Ware

cloves, goggles, boots, clothes

EV Tools required

battery lift, HV-Safe handtools, etc.

Features

Editable Test Voltage: 250-1000 V @ 1 mA

Generation of high voltage only at press of a button

Automatic discharge of transient current and voltage after the high-voltage insulation resistance test

High-voltage safety circuit (automatic switch-off)

Single Phase Power supply 100-250VAc @ 50/60Hz

Interface: USB 2.0 or later (galvanic insulated)

Function indicators (LED)

Printing Results Protocol

Database (Continuously Updated)

Expected
Production 2019



2 Battery Repair & Module Balancing

To guarantee an overall equal load of all cell modules on a HV-battery, the new cell module has to be charged / discharged to meet this load of the whole battery. The balanced cell module replaces the defect cell module of the battery.

3 Battery Leakage Test

Finally the battery tightness is very important to assure optimum operation of the battery out in the field. Dust and other particles can be very dangerous for the health of the battery of an EV/HEV.



Functions

Module Charging / Discharging

Safety test of the module and battery assembly

Self-test of system for accurate measurements and charging

Digital Leakage Testing -50... +50mbar

Digital Cooling System Testing for large volume battery housings

Reporting

NOTE: The BRSEV, is designed to be used in advanced workshops and dealerships which have been trained to work safely with HV battery repairs. To use this device, you must have a special qualification and training



Smartphone app & Bluetooth

The eBoostev AZO app provides extended control from your smartphone. In this way charging costs and CO2 savings can be evidenced.



- 230V 1-phase Schuko 2.3 kW
- 230V 1-phase CEE 3.7 kW
- 400V 3-phase CEE 11 kW
- 400V 3-phase CEE 22 kW



3-phase charging enables a charging power of up to 22 kW.

eBoostEV

charge fast anywhere

eBoostEV – Adapter-Set

With eBoostEV plug adapters, any power socket gets e-car safe and a stationary wallbox becomes unnecessary!

- Displays current, voltage and charging power
- Phase detection
- Monitoring of frequency and temperature
- Adjustable energy quantity and current
- Charging costs and CO2 savings can be evidenced
- Theft-Protected and Waterproof
- Compact and convenient
- Quality Product

Dimensions 215 x 90 x 84mm
Total weight 2,4kg to 4kg incl. cable
Nominal voltage 230V/400V 50Hz
Nominal current 16A, 32A
Max. charging power 11kW, 22kW
Residual current detection (RCD) AC 30mA, DC 6mA (EN 62752)
IP protection class IP66
Charge mode 2 acc. to EN 62752
Ambient conditions -30°C...+50°C (standard: +45°C), 5%-95% humidity
Vehicle plug Type 2 (IEC62196) or Type 1 (SAEJ1772)
Bluetooth connection Bluetooth Low Energy (BLE) **
Integrated energy meter for measuring of current, voltage, energy and power at all phases







Main Offices & Production Plant
364 Varis-Koropiu Ave. Koropi
194 42 Athens, Greece

Headquarters
A.I.S. GmbH
75438 Knittlingen, Germany

email contact@carbonzapp.com
tel +30 210 9856110
fax +30 210 9928655

carbonzapp.com