

MONOLIFT 800 0,8 t | 1200 1,2 t



 Sollevatore elettro-meccanico mono-colonna

 Electro-mechanical single post lift

 Elektromechanische Einsäulen-Hebebühne

 Elévateur électro-mécanique mono colonne

 Elevador electro-mecánico monocolumna



www.es-toolbox.com



 Chiocciola di sicurezza • Comandi uomo presente, 24V • Salvapiedi elettrici • Dispositivo di sicurezza elettro meccanico • Lubrificazione automatica • Funzionamento: elettromeccanico

 Safety nut • "Dead man" controls, 24V • Electric footguards • Electromechanical safety device • Automatic lubrication • Operation: electro-mechanical

 Sicherheitsmutter • Totmann-Schaltung, 24V • Elektrische Fusschutzvorrichtung • Elektromechanische • Automatische Schmierung • Funktionsweise: elektromechanisch

 Ecrou de sécurité • Commande "homme mort", 24V • Chasse-piedselectrique • Dispositif de sécurité électro-mécanique • Lubrification automatique • Fonctionnement: électromécanique

 • Tuerca de seguridad • Mandos de hombre presente, 24V • Dispositivo eléctrico salva pies • Dispositivo de seguridad electro-mecánico • Lubricación automática • Funcionamiento: electro-mecánico

MONOLIFT 800

0,8 t

1200

1,2 t

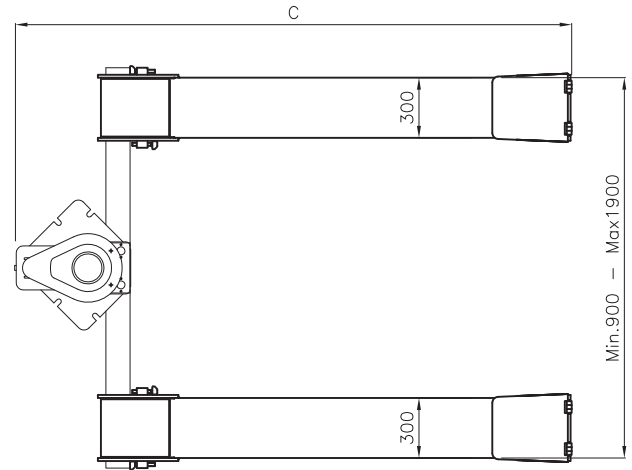
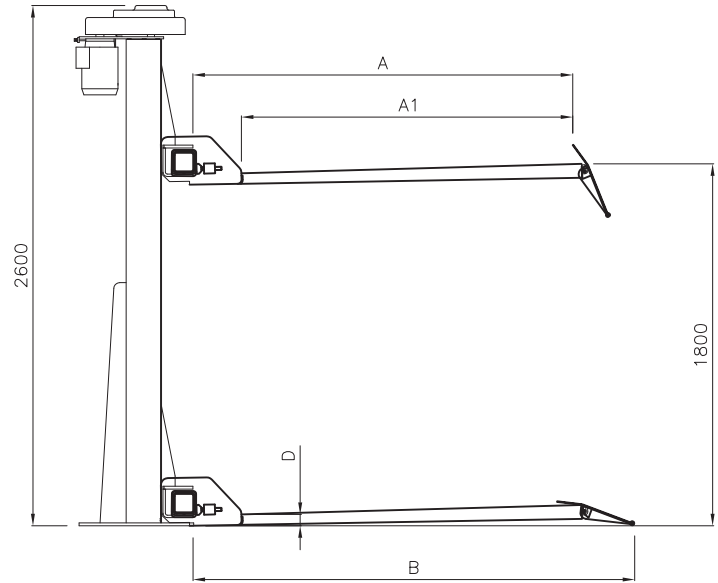
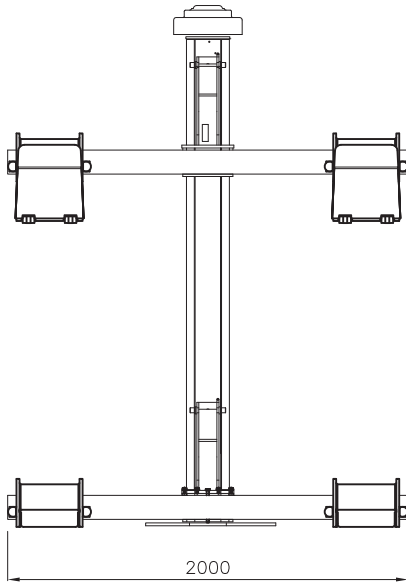

	800	1200
A	1900	2280
A1	1655	2040
B	2205	2585
C	2750	3165
D	60	80

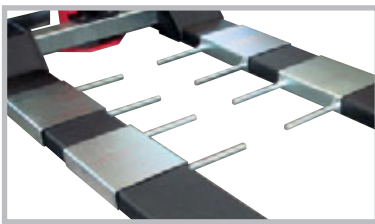

Kit forche
Forks kit

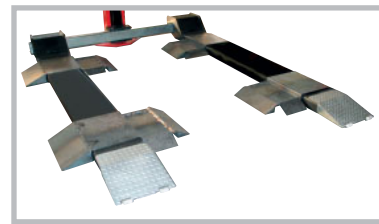

Kit rampe trasversali
Auxiliary ramps kit



800

1200

Dati tecnici	Technical data	Technische Eigenschaften	Caractéristiques techniques	Datos técnicos	800	1200
Portata	Capacity	Tragfähigkeit	Capacité	Capacidad	800 kg	1.200 kg
Peso	Weight	Gewicht	Poids	Peso	440 kg	500 kg
Salita/Discesa	Lifting/lowering	Hub/Senkzeit	Levage/descente	Subida/Bajada	55 s	55 s
Altezza di sollevamento	Lifting height	Hubhöhe	Hauteur de levage	Altura de elevación	1800 mm	1800 mm
Motore	Motor	Motorleistung	Puissance moteur	Motor	2,6 kW - 3 ph 230-400V/50 Hz	2,6 kW - 3 ph 230-400V/50 Hz